

# Essays in Agent-Based Macro and Monetary Economics

Inauguraldissertation  
zur Erlangung des akademischen Grades eines  
Doktors der Wirtschafts- und Sozialwissenschaften  
der Wirtschafts- und Sozialwissenschaftlichen Fakultät

der Christian-Albrechts-Universität zu Kiel

vorgelegt von  
Dipl.-Volksw. Matthias Lengnick  
aus Bielefeld, geb. 05.01.1984

Kiel, 2015

Gedruckt mit Genehmigung der Wirtschafts- und Sozialwissenschaftlichen Fakultät der  
Christian-Albrechts-Universität zu Kiel

Dekan: Prof. Dr. Achim Walter

Tag der Abgabe der Arbeit: 17. Dezember 2014

Tag der mündlichen Prüfung: 18. Februar 2015

Erstberichterstattender: Prof. Dr. Hans-Werner Wohltmann

Zweitberichterstattender: Prof. Dr. Thomas Lux

# Contents

|   |           |
|---|-----------|
| <b>List of Acronyms</b>   | <b>3</b>  |
| <b>1 Introduction</b>   | <b>5</b>  |
| <b>2 Agent-Based Financial Markets and New Keynesian Macroeconomics: A Synthesis</b>                | <b>9</b>  |
| <b>3 Optimal Monetary Policy in a New Keynesian Model with Animal Spirits and Financial Markets</b> | <b>11</b> |
| 3.1 Introduction . . . . .  | 12        |
| 3.2 Microfounding an Extended IS-Curve . . . . .  | 13        |
| 3.3 The Model . . . . .   | 15        |
| 3.4 Stability Analysis . . . . .  | 20        |
| 3.5 Optimal Monetary Policy . . . . .   | 24        |
| 3.6 Conclusion . . . . .  | 30        |
| 3.7 References . . . . .  | 31        |
| 3.8 Appendix . . . . .  | 34        |
| <b>4 Agent-Based Macroeconomics: A Baseline Model</b>   | <b>50</b> |
| <b>5 Money Creation and Financial Instability: An Agent-Based Credit Network Approach</b>           | <b>52</b> |
| 5.1 Introduction . . . . .  | 53        |
| 5.2 The ACE Method . . . . .  | 54        |
| 5.3 The Model . . . . .   | 55        |
| 5.4 The Endogenous Creation of Money . . . . .  | 62        |
| 5.5 The Interbank Market . . . . .  | 66        |
| 5.6 Endogenous Instability . . . . .  | 67        |
| 5.7 Standing Facilities, Reserve Requirements and Regulatory Policy . . . . .                       | 76        |
| 5.8 Conclusion . . . . .  | 79        |
| 5.9 References . . . . .  | 79        |
| <b>6 The Impact of Basel III on Financial (In)stability: An Agent-based Credit Network Approach</b> | <b>83</b> |

|  |           |
|--|-----------|
| <b>7 Outlook and Future Research</b>         | <b>85</b> |
| <b>Curriculum Vitae</b>                      | <b>87</b> |
| <b>Eidesstattliche Erklärung (Affidavit)</b> | <b>89</b> |

# List of Acronyms

|                     |  |
|---------------------|--|
| <b>ACE</b>          | Agent-based computational economics                        |
| <b>ABM</b>          | Agent-based models   |
| <b>ABC</b>          | Agent-based computational models                           |
| <b>AS</b>           | Animal Spirits   |
| <b>BA</b>           | Bank   |
| <b>BCBS</b>         | Basel Committee on Banking Supervision                     |
| <b>BR</b>           | Bounded rationality, boundedly rational                    |
| <b>CAR</b>          | Capita Adequacy Requirement                                |
| <b>CB</b>           | Central bank   |
| <b>CConB</b>        | Capital Conservation Buffer                                |
| <b>CCQ</b>          | Core capital quota   |
| <b>CCycB</b>        | Countercyclical Buffer                                     |
| <b>CET1</b>         | Common Equity Tier 1 Capital                               |
| <b>CsD</b>          | Cross-sectional Dimension of Systemic Risk                 |
| <b>DSGE</b>         | Dynamic stochastic general equilibrium                     |
| <b>ECB</b>          | European Central Bank                                      |
| <b>FASB</b>         | Financial Accounting Standards Board                       |
| <b>FAT</b>          | Financial activities tax                                   |
| <b>FM</b>           | Financial market   |
| <b>FOC</b>          | First order condition                                      |
| <b>FTT</b>          | Financial transaction tax                                  |
| <b>GDP</b>          | Gross domestic product                                     |
| <b>GE</b>           | General Equilibrium  |
| <b>G-SIB/G-SIFI</b> | Global Systemically Important Bank / Financial Institution |
| <b>HH</b>           | Household  |
| <b>HAM</b>          | Heterogeneous agent models                                 |
| <b>HQLA</b>         | High-quality Liquid Assets                                 |
| <b>IMF</b>          | International Monetary Fund                                |
| <b>LCR</b>          | Liquidity coverage ratio                                   |
| <b>LKW</b>          | Lengnick, Krug, Wohltmann (2013)                           |
| <b>LR</b>           | Leverage Ratio   |
| <b>MC</b>           | Monte carlo (simulation)                                   |
| <b>MSFE</b>         | Mean squared forecast error                                |

|             |   |
|-------------|---|
| <b>NSFR</b> | Net Stable Funding Ratio                |
| <b>ODD</b>  | Overview, Design concepts, Details      |
| <b>OSR</b>  | Optimal simple rule                     |
| <b>RBC</b>  | Real Business Cycle Theory              |
| <b>RE</b>   | Rational expectations                   |
| <b>ROE</b>  | Return on Equity                        |
| <b>RWA</b>  | Risk-weighted Assets                    |
| <b>SFC</b>  | Stock-flow consistent                   |
| <b>SINU</b> | Stock in non-separable utility          |
| <b>TvD</b>  | Time-varying Dimension of Systemic Risk |
| <b>VAT</b>  | Value-added tax                         |
| <b>ZIA</b>  | Zero intelligence agents                |

# Chapter 1

## Introduction

This dissertation consists of five published articles and working papers that deal with three major areas of economics using agent-based computational (ACE) methods: The first two articles (chapters 2 and 3) develop agent-based models to analyze the interaction between the real and financial sector and derive optimal policy reactions. The third article (chapter 4) presents a minimal agent-based model of the macroeconomy. Articles four and five (chapter 5 and 6) deal with simple models of the banking sector as well as optimal banking regulation.

### Chapter 2

In this chapter, we combine a simple agent-based model of financial markets with a New Keynesian macroeconomic model that is characterized by bounded rationality instead of Rational Expectations. The two employed submodels are simple representatives of their respective discipline. Interaction between the two is brought about by straightforward channels. The result is a macroeconomic model that allows for the endogenous development of business cycles and stock price bubbles. We also analyze the impact of different types of financial transaction taxes that are currently debated among policy makers: A financial transaction tax (FTT) in the spirit of Tobin (1978)<sup>1</sup>, a financial activities tax (FAT) which is analogous to a value-added tax, and a progressive version of the FAT.

The main findings are the following. We show that market sentiments of both, the real and financial sector, exert important influence on the macroeconomy: Impulse-response functions of macroeconomic variables become more volatile which makes the effect of a given shock more difficult to predict. With respect to financial taxation, we find that all considered taxes are well suited to stabilize the economy and raise funds from the financial sector as a contribution to the enormous costs created during the recent crisis. Our simulations suggest that the FTT leads to higher tax revenues and better stabilization results than the FAT. However, the FTT might also create huge macroeconomic distortions if set too high, a threat which the FAT does not imply. Furthermore, we have shown that the optimal decision of making the FAT flat or progressive is depending on the tax rate. For values below 11% the progressive version

---

<sup>1</sup>The list of references for each article is attached at the end of each chapters right after the corresponding conclusions.

is the best choice, while for rates above 40% the flat tax version is preferable. In between, the progressive tax leads to better stabilization while the flat tax generates more revenue.

The chapter is based on a joint article with Hans-Werner Wohltmann which was published as "Agent-Based Financial Markets and New Keynesian Macroeconomics: A Synthesis" in the *Journal of Economic Interaction and Coordination*, April 2013, Volume 8, Issue 1, pp. 1-32. My contribution consists of the entire programming as well as substantial parts of the literature research and theoretical model development.

### Chapter 3

This chapter further develops the model of article one. In a first step we simplify the real sector submodel and correct some minor inconsistencies of the underlying De Grauwe (2010a) model. Secondly, we use a strict microfoundation approach to derive a generalized IS-equation which gives rise to new interactive channels. In a third step we perform a detailed stability analysis of the interactive channels. Finally, we derive optimal monetary policy rules of the Taylor type under a set of different regimes: For example, we change the central bank's (CB) objective function by additionally taking financial market volatility into account. Additionally, we discuss the question whether optimal monetary policy should be forward- or backward-looking. Finally, we allow the CB to perform direct purchases of financial assets and derive the corresponding optimal *unconventional* (simple) rule.

Our most important findings are the following. The stability analysis yields ambiguous results. One channel is clearly destabilizing both, the real and financial sector. For the other channels, results either differ for both sectors (i.e. stabilizing one while destabilizing the other) or they change significantly with the set channels that are active. In some regimes, the interactive channels strongly feed back on each other and even yield explosive dynamics. Our analysis on optimal monetary policy shows that the coefficients of optimal simple Taylor rules do not significantly change if financial market stabilization becomes part of the CB's objective function. We find that the CB's response to inflation decreases slightly if financial market stability enters its objective. Another interesting result is that the optimal reaction to deviations of inflation from the target becomes weaker, the higher the degree of interaction between the financial and real sector. Additionally, we show that the policy rule should depend on contemporaneous values of output and inflation, if it reacts to lagged values instead, the economy is strongly destabilized. Additionally we analyze the importance of unconventional monetary policy instruments and find that they increase welfare only marginally in comparison to conventional policy.

The chapter is based on the joint article with Hans-Werner Wohltmann "Optimal Monetary Policy in a New Keynesian Model with Animal Spirits and Financial Markets" published as *Economics Working Papers* 2014, 12, Christian-Albrechts-University of Kiel, Department of Economics. My contribution consists of the entire programming as well as substantial parts of the literature research and theoretical model development. The microfoundation (outlined in detail in appendix 3.8.1) was derived by Hans-Werner Wohltmann alone.



## Chapter 4

This chapter presents a baseline agent-based macroeconomic model and contrasts it with the common dynamic stochastic general equilibrium approach. It is argued that its advantage over standard theory is the possibility of emergent phenomena and endogenous business cycles. The ACE method also provides a deeper way of microfoundation because it can strictly abandon any top-down assumption. E.g. market equilibrium is not assumed, but shown to emerge endogenously from the micro level. Thus, the method also allows for richer market dynamics: In the general equilibrium world, trade only takes place *after* the auctioneer has calculated the equilibrium price vector. In reality, however, prices are a result of the market mechanism and not its precondition (Kirman (2006) and Gaffeo et al. (2007)). Rationality assumptions (rational choice and rational expectations) are replaced by heuristics that real human beings would be able to apply. Furthermore, the model is validated since it reproduces a number of empirical facts.

It is demonstrated that agent-based modeling is an adequate response to the recently expressed criticism of macroeconomic methodology because it provides a solution to the above mentioned problems of DSGE theory. Additionally, it is capable of reproducing a lot of the stylized facts of business cycles. The developed model is simpler than other ACE competitors in the field of macroeconomics and solves all of the above mentioned issues of standard macroeconomic theory more rigorously.

The chapter is based on my single-authored article "Agent-Based Macroeconomics: A Baseline Model" in the *Journal of Economic Behavior and Organization*, February 2013, Volume 86, pp 102-120.

## Chapter 5

This chapter presents a simple agent-based, stock flow consistent model that covers the monetary side of transactions among households, firms and banks. All agents follow very simple behavioral rules. The resulting model is well suited to explain money creation in line with the standard theory of fractional reserve banking. Instead of enforcing an equilibrium by assumption, we show that it emerges endogenously from individual interactions in the long run. The model is therefore a generalization of standard theory. It is novel to the approach that individual interactions also create an interconnected banking sector which gives rise to systemic risk and bankruptcy cascades. Financial instability, in this model, is inevitably interwoven with the creation of money and thus an intrinsic property of modern economies.

It is shown that the existence of an interbank market has a twofold effect: It stabilizes during normal times but amplifies systemic instability, contagion and bankruptcy cascades during crises. But even with no interbank market, indirect contagion can lead to bankruptcy cascades. We identify maturity mismatches between different assets and liabilities as the driving force that, first, builds up systemic risk and, second, triggers financial crises endogenously. We also find that the existence of large banks threatens stability and that regulatory policy should target large banks more strictly than small ones.

The chapter is based on a joint article with Sebastian Krug and Hans-Werner Wohltmann which was published as "Money Creation and Financial Instability: An Agent-Based

Credit Network Approach” in the journal *Economics: The Open-Access, Open-Assessment E-Journal*, Volume 7, Issue 32, pp 1-44. My contribution consists of the entire programming as well substantial parts of the literature research and theoretical model development.

## Chapter 6

The last chapter deals with the new Basel III accord on banking regulation. With the Basel III framework, regulators have reacted to the recent financial crisis with, first, a revision of microprudential instruments and, second, the introduction of several new macroprudential instruments. This approach of cumulating several requirements bears the risk of single measures negating or even conflicting with each other, which might lessen their desired effects on financial stability. Hence, the question arises, whether the concurrent imposition of instruments leads to a regulatory environment in which they (perhaps partially) offset each other’s individual contribution to financial stability.

We use the model proposed in chapter 5 to provide an impact study of Basel III which evaluates both, the isolated and joined impact, of most of its instruments. The literature, of course, has already evaluated most instruments. Unfortunately, most of the available studies deal with single instruments only, thus providing no insight into potential conflicts between them. To get the joined impact of several (or all) instruments, one can not simply sum up the contributions of individual instruments in isolation. Our model allows for the simultaneous imposition of several instruments. It also gives rise to the sources of systemic risk (cross sectional & time varying) that Basel III aims to reduce. Hence, our model is well suited for an impact study of Basel III.

With respect to microprudential instruments, we find that the positive joint impact of all instruments is considerably larger than the sum of individual contributions, i.e. the stand-alone impacts are non-additive. Concerning the macroprudential overlay, the impacts are either marginal or even destabilizing except for the buffers (CConB and CCycB) which indeed represent indispensable instruments to counteract agents’ procyclical behavior. It is worth mentioning that two instruments contribute most to financial stability: The newly introduced liquidity coverage ratio (microprudential), and the flexible (i.e. buffered) capital requirement (macroprudential). Although the leverage ratio embodies a synthesis of both, non-risk sensitivity and simplicity, it falls short of expectations. The same holds for surcharges on systemically important institutions which have a quite moderate standalone and even destabilizing multi-dimensional impact. Hence, surcharges in their current implementation only contribute to financial regulations complexity and not to the resilience of the system.

The chapter is based on a joint article with Sebastian Krug and Hans-Werner Wohltmann entitled ”The Impact of Basel III on Financial (In)stability: An Agent-based Credit Network Approach” in *Quantitative Finance* (forthcoming). My contribution consists of the entire programming as well as substantial parts of the literature research and theoretical model development. The extensive literature work on banking regulation in general and the BASEL III accord in particular was done by Sebastian Krug.

## Chapter 2

# Agent-Based Financial Markets and New Keynesian Macroeconomics: A Synthesis

*Published in:* Journal of Economic Interaction and Coordination, April 2013, Volume 8, Issue 1, pp. 1-32

*Coauthored by:* Hans-Werner Wohltmann

### Abstract

We combine a simple agent-based model of financial markets and a New Keynesian macroeconomic model with bounded rationality via two straightforward channels. The result is a macroeconomic model that allows for the endogenous development of business cycles and stock price bubbles. We show that market sentiments exert important influence on the macroeconomy: Impulse-response functions of macroeconomic variables become more volatile which makes the effect of a given shock hard to predict. We also analyze the impact of different types of financial transaction taxes that are currently debated among policy makers (FTT, FAT, progressive FAT) and find that such taxes are well suited to stabilize the economy and raise funds from the financial sector as a contribution to the enormous costs created during the recent crisis. Our simulations suggest that the FTT leads to higher tax revenues and better stabilization results than the FAT. However, the FTT might also create huge distortion if set too high, a threat which the FAT does not imply.

*Keywords:* Agent-based modeling, stock market, New Keynesian macroeconomics, financial transaction tax, financial activities tax

*JEL classification:* E0, E62, G01, G18

The full article can be downloaded via  
<http://link.springer.com/article/10.1007/s11403-012-0100-y>

DOI: 10.1007/s11403-012-0100-y

## Chapter 3

# Optimal Monetary Policy in a New Keynesian Model with Animal Spirits and Financial Markets

*Published in:* Economics Working Papers 2014, 12, Christian-Albrechts-University of Kiel, Department of Economics

*Coauthored by:* Hans-Werner Wohltmann

### Abstract

This paper relates to the literature on macro-finance-interaction models. We modify the boundedly rational New Keynesian model of De Grauwe (2010a) using a completely micro-founded IS equation, and combine it with the agent-based financial market model of Westerhoff (2008). For this purpose we derive four interactive channels between the financial and real sector where two channels are strictly microfounded. We analyze the impact of the different channels on economic stability and derive optimal (simple) monetary policy rules. We find that coefficients of optimal simple Taylor rules do not significantly change if financial market stabilization becomes part of the central bank's objective function. Additionally, we show that rule-based, backward-looking monetary policy creates huge instabilities if expectations are boundedly rational.

*Keywords:* Agent-based financial markets; New Keynesian macroeconomics; microfoundation; optimal monetary policy; unconventional monetary policy

*JEL classification:* E03, E5, G02

### 3.1 Introduction

The financial crisis of 2008 has put new issues on the economics research agenda. Recently, a growing literature investigates how speculative phenomena in financial markets spill over to the real economy and whether or not real market developments feed back on financial speculation. One straightforward way to answer such questions is to integrate the standard New Keynesian macroeconomic (NKM) model with those of the agent-based computational (ACE) finance literature.

Early attempts in this area are Kontonikas and Ioannidis (2005) and Kontonikas and Montagnoli (2006) who connect a New Keynesian Macroeconomic (NKM) model with a financial market (FM) model where stock prices result from two different sources: a momentum-effect and a reversal towards the fundamental value. Those models are clearly inspired by the agent-based (chartist/fundamentalist) literature<sup>1</sup> on financial markets. A similar approach can also be found in Bask (2011). The major drawback of these models is the lack of a consistent approach of expectation formation. The Rational expectations (RE) hypothesis which is standard in macroeconomics is kept for the NKM part while financial markets are driven by non-rational expectations that are implicitly contained in the behavior of chartists / fundamentalists (compare Brock and Hommes (1998) for example).

Some interesting work in the macro-finance-interaction literature that does not build upon NKM for the description of the real sector has been done by Westerhoff (2012) and Naimzada and Pireddu (2013). The authors employ a classical Keynesian demand function only to represent the real sector. The advantage of this approach is simplicity. Models are typically of small scale, so that analytical solutions are tractable. This simplicity however comes at the cost of a non-microfounded, ad-hoc real economy.<sup>2</sup>

In a series of papers Paul DeGrauwe<sup>3</sup> has proposed to replace the assumption of rational expectations in standard NKMs by an evolutionary learning approach. Following the ACE-FM literature (e.g. Beja and Goldman (1980)), agents in his model apply different forecasting heuristics and adjust their believes by ex post evaluation. His approach provides a perfect real sector submodel to an integrated (i.e. macro-finance-interaction) model framework because it allows to state both submodels using identical expectations hypothesis. A first approach to integrate NKM of the DeGrauwe type with ACE financial markets has been proposed by Lengnick and Wohltmann (2013). The authors put a Westerhoff (2008) model alongside the DeGrauwe NKM and introduce two different interaction channels.

In the paper at hand we will further develop this approach in the following way. In section 3.2 we will derive an extended version of the IS-curve that gives rise to new interactive channels with the financial sector. In section 3.3 we will adjust the expectations heuristics of the real sector subsystem and define the macro-finance-interaction model. The role of the different

---

<sup>1</sup>A literature overview can be found in Samanidou et al. (2007), an empirical model contest in Franke and Westerhoff (2012). For illustrative examples on exchange rate modeling consult De Grauwe and Grimaldi (2005) and Bauer et al. (2009).

<sup>2</sup>A new literature designs agent-based macroeconomic models as object oriented simulations without the need for any equation system. Consult Lengnick (2013) for a simple example and Dosi et al. (2010) for a very elaborate, policy oriented one.

<sup>3</sup>De Grauwe (2010a), De Grauwe (2010c), De Grauwe (2010b).

channels on (in)stability is evaluated in section 3.4. In section 3.5 we derive optimal simple monetary policy rules of the Taylor-type and discuss the question whether they should be forward- or backward-looking. Section 3.6 concludes.

### 3.2 Microfounding an Extended IS-Curve

One important aspect on the research agenda to integrate NKM with ACE finance is the identification of the most important channels through which the different sectors influence each other. Several channels have been proposed, but all of them share two common problems: First, the interactive channels are not microfounded or empirically identified but assumed ad hoc. Second, the literature has not agreed upon which channels are most important.

Typical assumptions for possible channels which affect the real sector from within the financial one are, (1) the existence of wealth effects (Kontonikas and Montagnoli (2006), Bask (2011), Westerhoff (2012), Naimzada and Pireddu (2013)), (2) a collateral based cost effect (Lengnick and Wohltmann (2013)) or (3) a balance-sheet based leverage targeting effect (Scheffknecht and Geiger (2011)). Typical examples for channels going in the opposite direction are (1) a misperception effect (Kontonikas and Montagnoli (2006), Westerhoff (2012), De Grauwe and Kaltwasser (2012), Lengnick and Wohltmann (2013), Naimzada and Pireddu (2013)), (2) a negative dependence on the (real) interest rate (Kontonikas and Montagnoli (2006)), or (3) a mixture of both (Bask (2011)).

But even if the same type of channel is applied, its formalization is often very different. The wealth effect, for example, is formalized in Kontonikas and Montagnoli (2006) and Westerhoff (2012) by adding  $+c_1 s_q$  to aggregate demand, where  $c_1$  is a positive parameter and  $s_q$  the (log) stock price in period  $q$ . On the other hand, Bask (2011) adds real stock price changes  $+c_1(\Delta s_q - \pi_q)$ , where  $\pi_q$  is the inflation rate. Naimzada and Pireddu (2013) add a weighted average of the current and fundamental stock price  $+c_1 [(1 - \omega)s^f + \omega s_q]$  where  $\omega$  is the weight and  $s^f$  the fundamental value of  $s_q$ .<sup>4</sup> In the remainder of this section, we will derive channels that follow from a strict microfoundation approach, to check which of the above mentioned channels and formalizations are in line with first order principles.

In NKM, money is typically introduced by assuming that holding money generates utility for the household. To introduce stocks within the NKM microfoundation framework, we proceed analogously and assume that holding stocks creates utility in just the same way. Following Gali (2008, p. 27-32) the household's period utility function is given by

$$U(C_q, D_q, N_q) = \frac{Z_q^{1-\sigma}}{1-\sigma} - \frac{N_q^{1+\eta}}{1+\eta} \quad (3.1)$$

with  $Z_q$  being a composite index defined as:

$$Z_q = \left[ \alpha_1 C_q^{1-\nu} + \alpha_2 D_q^{1-\nu} \right]^{\frac{1}{1-\nu}} \quad (3.2)$$

---

<sup>4</sup>Compare Kontonikas and Montagnoli (2006), eq. (3); Westerhoff (2012), eq. (2.3); Bask (2011), eq. (1); Naimzada and Pireddu (2013), section 2.1.

In the remainder of this paper we will call this approach *stock in non-separable utility* [SINU].

Consumption is given by  $C_q$ , labor supply by  $N_q$  and the amount of stock demand by  $D_q$ . Utility is maximized with respect to the budget constraint:

$$C_q + \frac{S_q D_q}{P_q} + \frac{T_q^n}{P_q} + \frac{B_q}{P_q} = \frac{W_q}{P_q} N_q + \left( \tilde{d}_{q-1} + S_{q-1} \right) \frac{D_{q-1}}{P_q} + (1 + i_{q-1}) \frac{B_{q-1}}{P_q} \quad (3.3)$$

$S_q$  denotes the stock price,  $T_q^n$  nominal taxes,  $B_q$  bonds demand,  $P_q$  the goods price and  $\tilde{d}_{q-1}$  is the dividend payment per stock. The costs of current (real) stock demand  $\frac{S_q D_q}{P_q}$  appears on the left hand side of (3.3) while the (real) worth of past stock demand plus (real) dividend receipts  $\left( \tilde{d}_{q-1} + S_{q-1} \right) \frac{D_{q-1}}{P_q}$  is added to the right hand side. It is assumed that dividend payments  $\tilde{d}_{q-1}$  are earned by firms in  $q-1$  and distributed to households at the beginning of period  $q$ .

Solving the above optimization problem for an infinitely lived household yields the stock demand function<sup>5</sup>

$$d_q = x_q - c_3(s_q - p_q) - c_4 i_q \quad (3.4)$$

where lower case letters denote log differences, i.e. relative deviations from steady state. Interpretation of the dependencies of  $d_q$  is straightforward: (1) The demand for stocks increases if an agent can afford higher consumption (which results in a higher output gap  $x_q$ ). (2) The higher the real price of stocks  $s_q - p_q$ , the lesser its demand. (3)  $d_q$  also depends on bond yields  $i_q$ , because bonds are a substitute for stocks: If bonds demand becomes more profitable, stock demand would decrease. Note that stock demand does not (directly) depend on the expected stock price change between  $q$  and  $q+1$  because households' behavior is not driven by a speculative motive of stock demand.

The extended IS curve becomes

$$x_q = E_q[x_{q+1}] - \frac{1}{\sigma} (i_q - E_q[\pi_{q+1}]) + c_1 \cdot E_q[\Delta s_{q+1} - \pi_{q+1}] + c_2 \cdot E_q[\Delta i_{q+1}] + \epsilon_q^x \quad (3.5)$$

with the two new (positive) constants  $c_1$  and  $c_2$ . A detailed derivation can be found in appendix 3.8.1. The interpretation of (3.5) is again straightforward and closely follows Gali (2008, chapter 2.5.2). In the case of expected (real) stock price increases ( $E_q[\Delta s_{q+1} - \pi_{q+1}] > 0$ ), households expect future (real) stock prices to be higher than today. Hence, they expect lower stock demand for the future compared to today ( $d_{q+1} < d_q$ , see eq. (3.4)). Consequently, marginal utility of future consumption is lower than of current consumption. To smooth marginal utility of consumption in  $q$  and  $q+1$ , current consumption is increased. The same rationale holds for the expected change in government bond yields. If  $i_q$  is expected to rise ( $E_q[\Delta i_{q+1}] > 0$ ) future stock demand is expected to be lower than today ( $d_{q+1} < d_q$ ) which (as above) leads to increased current consumption and output.

Given the assumptions on the wealth effect of other authors (discussed above), we can conclude from this section that Bask (2011) was closest to a channel that is in line with utility

<sup>5</sup>Compare appendix 3.8.1 for a detailed derivation.



optimizing behavior although he had a slightly different timing ( $+c_1(\Delta s_q - \pi_q)$  instead of  $+c_1 \cdot \mathbb{E}_q [\Delta s_{q+1} - \pi_{q+1}]$ ).

### 3.3 The Model

One problem that has to be solved when joining a NKM model with an ACE-FM is that both are developed to run on different time scales because transactions in financial markets take place in much smaller time intervals (compared to the real market).<sup>6</sup> Time indices in the NKM represent quarters, while in ACE-FM they are interpreted as days.

To allow for a meaningful integrated model, we have to make sure that both submodels still run on the time scale they are designed for. For this purpose we assume that the financial market performs 64 increments of the time index  $t$  within one increment of the real market's time index  $q$  (figure 3.1). Quarter  $q$  consists of the days<sup>7</sup>  $t = 64(q - 1) + 1, \dots, 64q$ .<sup>8</sup>

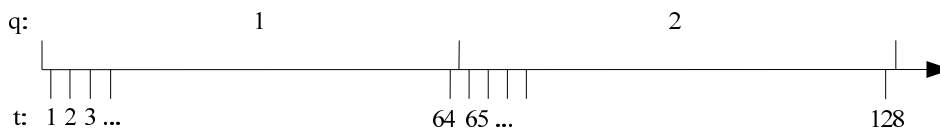

Figure 3.1: Time scale; indexed by days  $t$  and quarters  $q$

#### 3.3.1 Real Sector

The real sector of our integrated model consists of a Taylor rule, an inflation equation of the Phillips-type and our extended IS-Curve (3.5). To be able to compare the model to others in the literature<sup>9</sup> we also allow for a cost effect ( $-\kappa s_q$ ) in the Phillips Curve:

$$\pi_q = \beta \tilde{\mathbb{E}}_q [\pi_{q+1}] + \gamma x_q - \kappa s_q + \epsilon_q^\pi \quad (3.6)$$

The Taylor rule is depending on expected future inflation rate and output gap:<sup>10</sup>

$$i_q = \delta_\pi \left( \tilde{\mathbb{E}}_q [\pi_{q+1}] - \pi^* \right) + \delta_x \tilde{\mathbb{E}}_q [x_{q+1}] + \epsilon_q^i \quad (3.7)$$

The quarterly value of stock prices is given by the average of the corresponding daily values:<sup>11</sup>

$$s_q = \frac{1}{64} \sum_{t=64(q-1)+1}^{64q} s_t \quad (3.8)$$

<sup>6</sup>Algorithmic trading, for example, which is typically of a very short-term intra-daily nature already accounts for up to 60% of financial market transactions (Matheson (2011)). Such high frequencies are unusual for transactions of the real economy, e.g. labor is bought for at least one month. Consult also the approach of Franke and Sacht (2014) and Ahrens and Sacht (2014).

<sup>7</sup>It is assumed that trading does not take place on weekends.

<sup>8</sup>Lengnick and Wohltmann (2013), section 2.

<sup>9</sup>Compare literature overview in section 3.1.

<sup>10</sup>We relax this assumption in section 3.5.

<sup>11</sup>Compare Lengnick and Wohltmann (2013), eq. (24)

Alternatively, one could assume decaying weights to account for the fact that recent information has a stronger influence on traders than older information. It has been shown that the model outcome is robust against this assumption.<sup>12</sup>

Expectations are formed in a boundedly rational way using discrete choice learning. For the output gap the set of heuristics is given by:

$$\text{Targeters: } \tilde{E}_q^{\text{tar}} [x_{q+1}] = \bar{x} \quad (3.9)$$

$$\text{Static exp.: } \tilde{E}_q^{\text{sta}} [x_{q+1}] = x_{q-1} \quad (3.10)$$

$$\text{Extrapolaters: } \tilde{E}_q^{\text{ext}} [x_{q+1}] = x_q + \alpha_x \cdot [x_q - x_{q-1}] \quad (\alpha_x > 0) \quad (3.11)$$

Compared to the original De Grauwe model, we assume a different set of expectations that is more in line with those typically assumed in ACE-FM.<sup>13</sup> Additionally, we do not assume a hybrid form for the IS- and Phillips-Curve, because the boundedly rational expectations approach (especially static exp.) already gives rise to persistence in line with the rule-of-thumb idea. A hybrid form is therefore not necessary any more.<sup>14</sup>

A further advantage of our specification is that the special case of full price flexibility is still included in the model, while the original DeGrauwe model becomes explosive for high degrees of price flexibility. The NKM is derived by introducing real rigidities into the Real Business Cycle (RBC) model. Therefore, the RBC model is still incorporated in the NKM as a special case. This aspect is important conceptually and should also hold for a boundedly rational version of the NKM (compare appendix 3.8.5 for further details on this and other advantages of our specification).

For inflation, heuristics are given by:

$$\text{Targeters: } \tilde{E}_q^{\text{tar}} [\pi_{q+1}] = \pi_q^* \quad (3.12)$$

$$\text{Static exp.: } \tilde{E}_q^{\text{sta}} [\pi_{q+1}] = \pi_{q-1} \quad (3.13)$$

$$\text{Extrapolaters: } \tilde{E}_q^{\text{ext}} [\pi_{q+1}] = \pi_q + \alpha_\pi \cdot [\pi_q - \pi_{q-1}] \quad (\alpha_\pi > 0) \quad (3.14)$$

Depending on their past performance, measured by the mean squared forecast error (MSFE), each forecasting heuristic  $j \in \{\text{tar, sta, ext}\}$  is ascribed a level of *attractivity*

$$A^{y,j} = - \left( y_{q-1} - \tilde{E}_{q-2}^j [y_{q-1}] \right)^2 + \zeta A_{q-1}^{y,j} \quad y \in \{x, \pi\} \quad (3.15)$$

<sup>12</sup>Compare Lengnick and Wohltmann (2013), section 2 of online appendix.

<sup>13</sup>Compare, for example, the model of Westerhoff (2008) or De Grauwe and Grimaldi (2006) which is based on Brock and Hommes (1998). For an alternative approach where chartism is based on a moving average rule consult Chiarella et al. (2006).

<sup>14</sup>Introduction of hybridity into the baseline NKM is typically justified (microfounded) by assuming *habit formation* (Ravn et al. (2010), Smets and Wouters (2007)) or *rule-of-thumb* (Amato and Laubach (2003)) behavior. The BR expectations of DeGrauwe clearly fall in the second category because, first, they yield the same result on the aggregate level (i.e. persistence) and, second, they follow the four criteria (compare Amato and Laubach (2003) and Menz (2008)) for rule-of-thumb behavior: (1) They are applied if RE induce too high costs. (2) The orientation variable should be easily observable by the agents. (3) Calculating forecasts should involve virtually no computational burden. (4) Agents should learn, and learning algorithms should make sure that individual choices have converged once a steady state is reached.

with the memory parameter  $\zeta$ . The fraction of agents  $\omega_q^{y,i}$  applying heuristic  $i$  is given by a discrete choice model

$$\omega_q^{y,j} = \frac{\exp\{\phi A_q^{y,j}\}}{\exp\{\phi A_q^{y,\text{tar}}\} + \exp\{\phi A_q^{y,\text{sta}}\} + \exp\{\phi A_q^{y,\text{ext}}\}} \quad (3.16)$$

and *market expectations* are given by the weighted average:

$$\tilde{E}_q[y_{q+1}] = \sum_j \omega_q^{y,j} \tilde{E}_q^j[y_{q+1}] \quad (3.17)$$

De Grauwe points out<sup>15</sup>, that agents do not use heuristics (instead of RE) *"because they are irrational, but rather because the complexity of the world is overwhelming"* that ex ante calculation of mean time paths is impossible. Therefore, *"heuristics [are] a rational response of agents who are aware of their limited capacity to understand the world"*. In the remainder of the paper we will denote this response *boundedly rational* [BR] to distinguish it from strict RE.

To keep the model simple, we do not add a set of heuristics and a discrete choice learning model for interest rate expectations of eq. (3.5), but only use static expectations:  $\tilde{E}_q[i_{q+1}] = i_q$ . The solution of our real sector model is then given by (compare appendix 3.8.2)

$$\begin{pmatrix} x_q \\ \pi_q \end{pmatrix} = \mathbf{A}_q^{-1} \mathbf{C}_q \begin{pmatrix} x_{q-1} \\ \pi_{q-1} \end{pmatrix} + \mathbf{A}_q^{-1} \mathbf{D}_q \cdot s_q + \mathbf{A}_q^{-1} \mathbf{F}_q \cdot s_{q-1} + \mathbf{A}_q^{-1} \begin{pmatrix} \sigma \epsilon_q^x - \epsilon_q^i \\ \epsilon_q^\pi \end{pmatrix} \quad (3.18)$$

with the time dependent matrices:

$$\begin{aligned} \mathbf{A}_q &= \begin{pmatrix} \sigma - (\sigma - \delta_x) \omega_{x,q}^{\text{ext}} (1 + \alpha_x) - \sigma c_1 \omega_{s,q}^{\text{tar}} h & -(1 - \delta_\pi - \sigma c_1) \omega_{\pi,q}^{\text{ext}} (1 + \alpha_\pi) \\ -\gamma & 1 - \beta \omega_{\pi,q}^{\text{ext}} (1 + \alpha_\pi) \end{pmatrix} \\ \mathbf{C}_q &= \begin{pmatrix} (\sigma - \delta_x) (\omega_{x,q}^{\text{hab}} - \alpha_x \omega_{x,q}^{\text{ext}}) & (1 - \delta_\pi - \sigma c_1) (\omega_{\pi,q}^{\text{rof}} - \alpha_\pi \omega_{\pi,q}^{\text{ext}}) \\ 0 & \beta (\omega_{\pi,q}^{\text{rof}} - \alpha_\pi \omega_{\pi,q}^{\text{ext}}) \end{pmatrix} \\ \mathbf{D}_q &= \begin{pmatrix} c_1 \sigma (\omega_{s,q}^{\text{ext}} (1 + \alpha_s) - 1) \\ -\kappa \end{pmatrix} & \mathbf{F}_q = \begin{pmatrix} c_1 \sigma (\omega_{s,q}^{\text{sta}} - \alpha_s \omega_{s,q}^{\text{ext}}) \\ 0 \end{pmatrix} \end{aligned}$$

### 3.3.2 Financial Sector

We use the model of Westerhoff (2008) for the financial sector of our economy.<sup>16</sup> In this section, we will shortly describe the original Westerhoff model. Afterwards it will be adjusted to allow for interactions with the real economy.

<sup>15</sup>De Grauwe (2010b), p. 415.

<sup>16</sup>We decided to use this model because because of its straightforward assumptions and implementation. The model is also empirically validated and has successfully been used for policy analysis. For alternative models compare Dieci and Westerhoff (2010) or Tramontana et al. (2013). An interesting example on a much debated policy issue can be found in Westerhoff and Dieci (2006).

In this model, agents learn from a set of two different rules:

$$\text{Chartists: } \tilde{E}_t^C [s_{t+1}] = s_t + k^C [s_t - s_{t-1}] \quad (3.19)$$

$$\text{Fundamentalists: } \tilde{E}_t^F [s_{t+1}] = s_t + k^F [s_t^f - s_{t-1}] \quad (3.20)$$

Chartists believe in a continuation of the recently observed stock price trend while fundamentalists expect a reversal towards the fundamental value  $s_t^f$ . For both groups  $j$ , the excess demand for stocks  $D_t^j$  positively depends on the direction of the expected stock price change:

$$D_t^j = \ell \left( \tilde{E}_t^j [s_{t+1}] - s_t \right) + \epsilon_t^j \quad j \in \{C, F\} \quad (3.21)$$

Note that the above equation denotes excess demand of institutional investors of the financial market, while the completely microfounded eq. (3.4) denotes households' demand. The fractions of agents  $W_t^j$  applying the different strategies  $j$  are determined by a discrete choice model. In addition to strategies  $C$  and  $F$ , Westerhoff (2008) also allows a 'no trading'-strategy:

$$W_t^j = \frac{\exp\{eA_t^j\}}{\exp\{eA_t^C\} + \exp\{eA_t^F\} + \exp\{eA_t^0\}} \quad j \in \{C, F, 0\} \quad (3.22)$$

$A_t^j$  is the attractivity of strategy  $i$  that is determined as a function of past profits (cf. eq. (3.15)):

$$A_t^j = (\exp\{s_t\} - \exp\{s_{t-1}\}) D_{t-2}^j + mA_{t-1}^j \quad (3.23)$$

The parameter  $m \in (0, 1)$  determines the memory of traders and the attractivity of no trading is normalized to  $A_t^0 = 0$  (i.e. no profits). Price adjustment is given by a price impact function

$$s_{t+1} = s_t + a \left( W_t^C D_t^C + W_t^F D_t^F \right) + \epsilon_t^s \quad (3.24)$$

that relates stock price changes positively to excess demand  $(W_t^C D_t^C + W_t^F D_t^F)$ . The random term  $\epsilon_t^s$  denotes the influence of trading strategies other than  $j \in \{C, F, 0\}$ .

**Impacts from the Real Sector** For the first interactive channel, we follow Kontonikas and Montagnoli (2006), Westerhoff (2012), De Grauwe and Kaltwasser (2012), Lengnick and Wohltmann (2013)<sup>17</sup> and Naimzada and Pireddu (2013) by assuming, that the perceived fundamental value  $s_t^f$  is biased in the direction of the recent real economic development:<sup>18</sup>

$$s_t^f = h \cdot x_q \quad q = \text{floor} \left( \frac{t-1}{64} \right), \quad h \geq 0 \quad (3.25)$$

The completely microfounded *stock in non-separable utility* [SINU] approach gives rise to a second channel because households' demand for stocks (eq. (3.4)) has to be added to the demand of institutional investors of the financial market model (eq. (3.24)). If we assume

<sup>17</sup>Compare eq. (26) in Lengnick and Wohltmann (2013).

<sup>18</sup>The floor function in eq. (3.25) rounds a number down to the next integer.

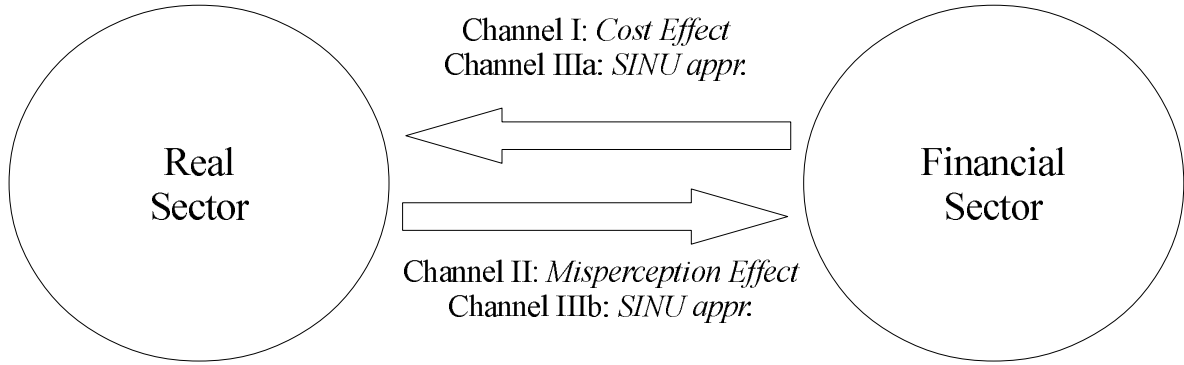

Figure 3.2: Real- and Financial Sector Interactions (Channels)

that households' (quarterly) demand for stocks is distributed evenly among the 64 days of the quarter, we have to add  $\frac{1}{64}\Delta d_q$  to stock demand such that the price impact function becomes:<sup>19</sup>

$$s_{t+1} = s_t + a \left( W_t^C D_t^C + W_t^F D_t^F + \frac{k}{64} \Delta d_q \right) + \epsilon_t^s \quad (3.26)$$

The parameter  $k$  is introduced as a generalization that allows to vary the intensity of the channel. For  $k = 0$  the channel disappears.

### 3.3.3 Financial and Real Sector Interaction

In total, we have four channels through which the financial and real sector could impact each other (fig. 3.2): Channels I and II that are in line with the literature, but assumed ad hoc, and channels IIIa and IIIb that are newly introduced by the microfounded SINU approach.

The economic rationale of channel I is that the nominal value of financial assets owned by firms increases when stock prices are rising. Firms' production is largely financed by credit. If their asset side of the balance sheet increases this leads to a rise in their credit worthiness and credit rating. Consequently, they have access to cheaper credits (compare Minsky (1986)). Hence, their costs of production fall which leads to lower prices. Channel IIIa results from intertemporal utility optimization of households. If households expect increasing real stock prices, they also expect falling marginal utility of consumption for the next period. Intertemporal utility smoothing makes them increase consumption today.

Channel II goes in the opposite direction and can be interpreted as follows. The *true* fundamental value of a given stock is hard to identify in reality (compare Rudebusch (2005), Bernanke et al. (1999)). If the true value of  $s_t^f$  is unknown, agents have to form assumptions about it. In our model they use proxies like the recent economic development. If output is high, they assume the fundamental value to be high and adjust their demand for stocks accordingly. The fourth channel, ch. IIIb, also results from the microfounded SINU approach. According to eq. (3.4), stock demand increases if (1) output increases, (2) the real stock price

<sup>19</sup>Note that stock prices react to *excess* demand which is given by  $\Delta d_q$ , not  $d_q$ .

decreases, or (3) the nominal interest rate decreases. In all three cases, increasing demand will drive stock prices upward.

The intensity of each channel is given by the corresponding interaction parameters  $\kappa$  (Channel I),  $h$  (II),  $c_1$  (IIIa) and  $k$  (IIIb). In the special case of  $\kappa = h = c_1 = k = 0$  the two submodels operate in isolation.

### 3.4 Stability Analysis

In this section we are going to determine for each channel whether it is stabilizing or destabilizing the economy. For this purpose, we will vary the interaction parameters  $\kappa$ ,  $h$ ,  $c_1$  and  $k$  on an interval from zero (i.e. no interaction) upwards. All other parameters are kept constant. We report them in table 3.1 and keep them as our baseline parameterization throughout the entire paper. The impact on (in)stability of the real sector is measured by a typical central banks' loss function which is given as a weighted sum of the unconditional variances of inflation and output:<sup>20</sup>

$$\text{Real Sector: } L_r = \text{var}(\pi) + \frac{1}{2}\text{var}(x) \quad (3.27)$$

The interpretation of (3.27) is that volatile goods price inflation and production are associated with utility losses, where output stabilization is weighted half as much as price stability. Similarly, we set up a loss function for the financial sector

$$\text{Financial Sector: } L_f = \text{var}(s) \quad (3.28)$$

that associates volatile daily<sup>21</sup> stock prices with losses.

Table 3.1: Baseline parameterization

| Real sector        |                               |                          | Financial sector |              |                   |
|--------------------|-------------------------------|--------------------------|------------------|--------------|-------------------|
| Structure          | Learning                      | Noise                    | Structure        | Learning     | Noise             |
| $\sigma = 1.0$     | $\zeta = 0.5$                 | $\sigma_\epsilon = 0.15$ | $\ell = 1$       | $k^C = 0.04$ | $\sigma_C = 0.05$ |
| $\beta = 0.99$     | $\phi = 10$                   |                          | $a = 1$          | $k^F = 0.04$ | $\sigma_F = 0.01$ |
| $\gamma = 0.33$    | $\alpha_x = \alpha_\pi = 0.2$ |                          |                  | $e = 300$    | $\sigma_s = 0.01$ |
| $\delta_x = 0.5$   |                               |                          |                  | $m = 0.975$  |                   |
| $\delta_\pi = 1.5$ |                               |                          |                  |              |                   |

Source: The Financial market parameterization is identical to Westerhoff (2008). The structural parameters of the real sector are standard in NKM (compare Gali (2008)):  $\sigma = 1.0$  gives rise to log utility,  $\beta = 0.99$  yields a steady state interest rate of about 4%.  $\gamma = 0.33$  follows if a unitary Frisch elasticity, a markup of 20%, constant returns to scale and price stickiness of  $\theta = 0.67$  are assumed. For the NKM learning parameters we follow De Grauwe (2010a,b,c) and Lengnick and Wohltmann (2013). For the new extrapolative heuristic, we assume a positive but mild trend extrapolation of 0.2.

<sup>20</sup>Compare e.g. Svensson (2003).

<sup>21</sup>Recall that daily stock prices are given by  $s_t$ , while quarterly are given by  $s_q$ .

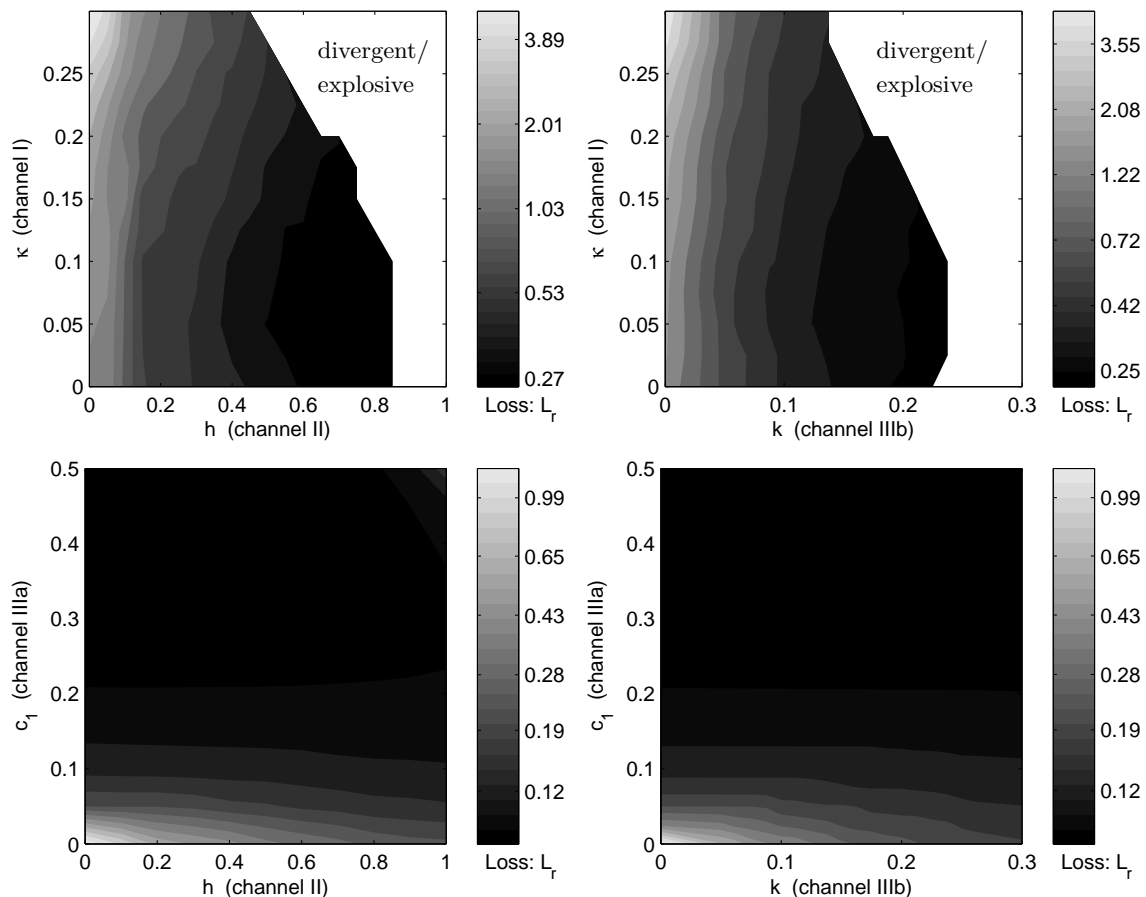

Figure 3.3: (De)stabilization of real submodel. Light gray areas denote parameterizations that yield high loss values (i.e. low welfare), while dark gray areas denote low losses. White areas, on the contrary, denote explosiveness.

To evaluate the effect of the four different interactive channels on economic stability, we proceed as follows. First, we pick pairs of two interaction parameters with opposed direction.<sup>22</sup> Second, we run the model for different values of the interactive parameters and for different realizations of the noise terms  $(\epsilon_q^i, \epsilon_q^x, \epsilon_q^\pi, \epsilon_t^s) \forall q, t$ . Finally, we compute the average loss values (eq. (3.27) and (3.28)) for a given parameterization which yields (approximately) the theoretical values  $L_r$  and  $L_f$ .<sup>23</sup>

In fig. 3.3 we illustrate the stabilization impact on the real sector. White areas (in the north-east) denote parameterizations for which no stable solution exists, i.e. the generated trajectories diverge/explode. Gray areas denote parameterizations that are non-explosive and the darkness indicates the corresponding loss value. The darker a region, the lower the associated loss  $L_r$ . The corresponding results for financial sector stabilization ( $L_f$ ) are displayed in figure 3.4.

<sup>22</sup>For example, the parameter pair  $(\kappa, h)$  constitutes one channel that effects the financial sector from within the real sector and one channel of the opposite direction.

<sup>23</sup>This procedure is related to the approach of Naimzada and Pireddu (2013) who also vary the interaction parameter ( $\omega$  in their paper) to analyze stability. But instead of a loss function, the authors use bifurcation plots to illustrate stability impacts.

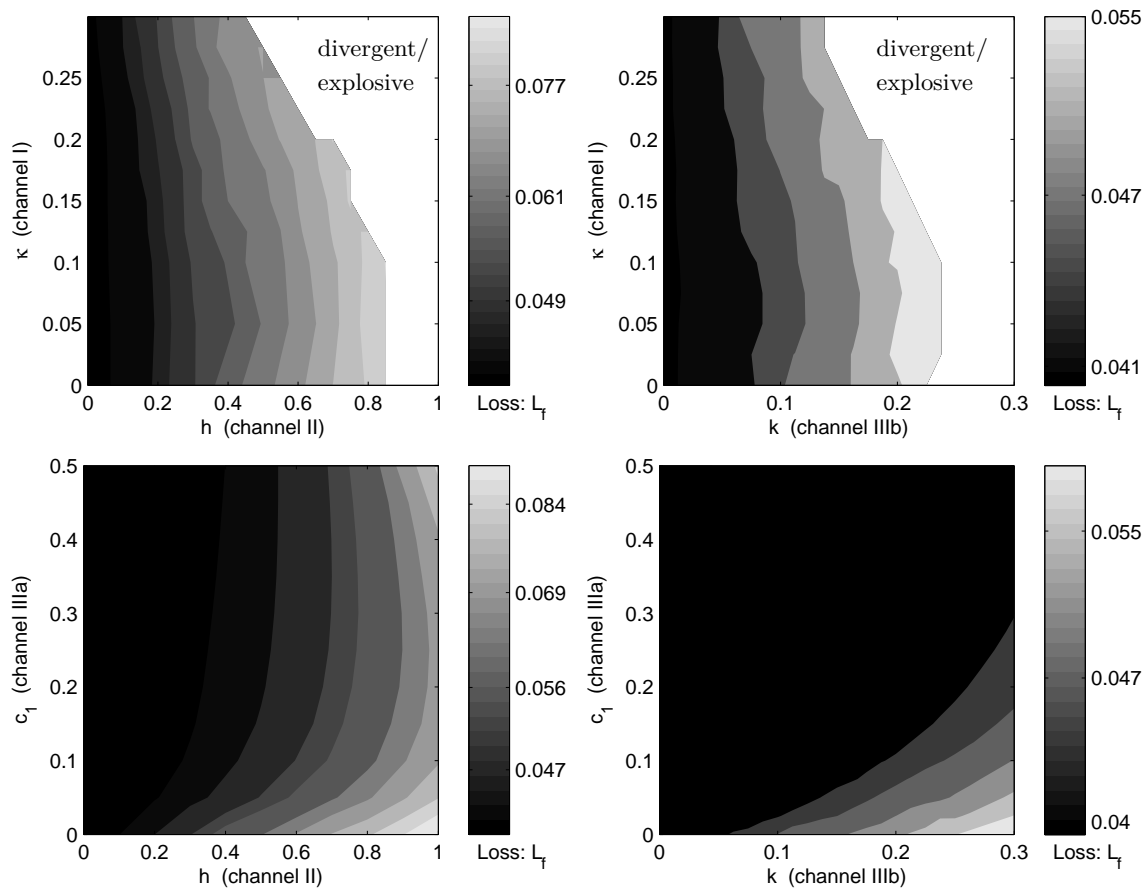

Figure 3.4: (De)stabilization of financial submodel. Light gray areas denote parameterizations that yield high loss values (i.e. low welfare), while dark gray areas denote low losses. White areas, on the contrary, denote explosiveness.

**Channel I ( $\kappa$ )** The influence of  $\kappa$  on welfare is clearly negative for both, the real and financial subsystem. For a given  $h$  or  $k$ , an increase of  $\kappa$  leads to higher loss values. For  $h > 0.45$  or  $k > 0.14$  it even gives rise to explosive developments. E.g. if, in the top left panel of fig. 3.3, we fix  $h = 0.2$  and let  $\kappa$  increase from 0 upwards, we successively reach areas of higher  $L_r$  (i.e. higher loss/volatility, lower welfare). If we fix  $h = 0.8$ , the system even becomes explosive (i.e. no stable trajectory) as soon as  $\kappa > 0.12$ .

The economic explanation for this explosive behavior is straightforward. If stock prices increase, inflation will fall due to (negative) cost effects (eq. (3.6)). Lower inflation leads to lower inflation expectations (eq. (3.14)) and therefore also to an increase in output (if the extended Taylor principle  $\delta_\pi > 1 + \sigma c_1$  holds). The rising output creates a feedback mechanism that drives stock prices up further, no matter which of the opposing channels (II or IIIb) is active. If channel II is active ( $h > 0$ ), a higher perceived fundamental value leads to higher demand for stocks (eq. 3.25), while if channel IIIb is active ( $k > 0$ ), households directly demand more stocks (eq. 3.4) which drives prices up.

**Channel II ( $h$ )** For parameter  $h$  we find somewhat ambiguous results. Financial markets are always destabilized (for I and IIIa being the opposing channel). For sufficiently large  $\kappa$ ,



an increase in  $h$  could even lead to explosive behavior. With respect to the real sector the results are not as clear. In combination with a significant strength of channel IIIa ( $c_1 > 0.1$ ), increasing values of  $h$  are stability neutral w.r.t.  $L_r$ , while for  $c_1 < 0.1$  a rise in  $h$  increases stability. In combination with channel I, higher  $h$  lead to more stable developments at first. If, however,  $h$  is increased above a certain threshold, the model suddenly becomes explosive.

**Channel IIIa ( $c_1$ )** Results for  $c_1$  are again ambiguous. When combined with channel IIIb, the impact of higher  $c_1$  is stabilizing for both, the real and the financial sector. When combined with channel II, higher values of  $c_1$  are only stabilizing the real sector but are almost neutral with respect to the financial one.

The economic intuition behind these results is the following. If channels IIIa and IIIb are active, an increase in output leads to higher stock demand of households (eq. (3.4)) and therefore higher stock prices. Through channel IIIa (eq. (3.5)), output depends positively on the expected future change in stock prices ( $\tilde{E}_q[\Delta s_{q+1}] = \tilde{E}_q[s_{q+1}] - s_q$ ). Higher stock prices ( $s_q$ ), therefore negatively effect output which dampens the original effect and stabilizes the economy.

If IIIa is combined with II one would expect the same results, since channel II (just as IIIb) positively relates stock prices to output development (eq. (3.25)). Channel II, however, depends on market sentiments: Only if the fraction of fundamentalists in the financial market is significantly high, we could expect the misperception effect (channel II) to have a significant impact. Obviously, this dependence on market sentiments weakens the stabilizing effect of larger values of  $c_1$ : Only for  $c_1 < 0.12$  we find a positive stabilization for both markets, while for  $c_1 > 0.12$  only the real sector is stabilized by further increases of  $c_1$ .

**Channel IIIb ( $k$ )** The stability impact of  $k$  also depends on the active channels: In combination with channel I, channel IIIb has a stabilizing effect on the real market as long as  $k$  is sufficiently small. At the same time, it has a destabilizing effect on the financial sector. If  $k$  is increased by too much, however, the model dynamics become explosive (compare explanation under paragraph 'channel I ( $\kappa$ )').

In combination with channel IIIa, results are very different. Higher values of  $k$  have a positive impact on real sector stability but only for low values of  $c_1$ . Financial market stability, in contrast, is monotonically decreasing.

In a last step, we check whether the stabilizing effect of one channel could counteract the destabilizing effect of other channels by so much that a formerly explosive parametrization becomes unexplosive. As an example, we pick the parameter combinations ( $h = 0.8$ ,  $\kappa = 0.25$ ) or ( $k = 0.25$ ,  $\kappa = 0.25$ ) which both yield explosive dynamics (figure 3.4, top left and top right). If, additionally to these two channels, we set  $c_1 = 0.15$  the model becomes stable again in both cases. Increasing  $c_1$  therefore shifts the unstable (white) region outwards.

From this section we can conclude that there is no easy answer to the question whether interaction between financial markets and the real economy is stabilizing or destabilizing. The

results depend strongly on the channels under consideration. Hence, future research has to clarify which of the proposed channels is most relevant empirically.<sup>24</sup>

### 3.5 Optimal Monetary Policy

In this section we will derive simple optimal policy rules for the central bank. In subsection 3.5.1 we derive optimal values for the Taylor parameters  $\delta_\pi$  and  $\delta_x$  under different types of policy rules and for different objective functions. In subsection 3.5.2 we analyze whether monetary policy should optimally be forward- or backward-looking.

#### 3.5.1 Optimal Simple Rule

We use the Taylor rule (3.7) and define the optimal simple rule [OSR] as the central banks' reaction  $(\delta_\pi^*, \delta_x^*)$  that yields the minimal loss value. In analogy to the previous section, we derive  $(\delta_\pi^*, \delta_x^*)$  as the minimizers of the average loss value over different realizations of the noise vector  $(\epsilon_q^i, \epsilon_q^x, \epsilon_q^\pi, \epsilon_t^s) \forall q, t$ :

$$(\delta_\pi^*, \delta_x^*) = \arg \min_{\delta_\pi, \delta_x} L_r \quad (3.29)$$

In this context, two straightforward questions arise in our interactive model: Does the presence of a financial sector change the optimal policy rule? If it does, to what extent do the different interactive channels matter?

To answer these questions, we are going to perform the optimization (3.29) for different cases: On the one hand, we assume different objective functions for the central bank. In a first setting we assume the typical form of a loss function where only the stability of the real subsystem is taken into account:

$$\text{Real sector only: } L_r = \text{var}(\pi) + \frac{1}{2} \text{var}(x) \quad (3.30)$$

In a second scenario we also add financial market stability  $\text{var}(s)$  with a relatively smaller weight:

$$\text{Real \& fin. sector: } L_{r+f} = \text{var}(\pi) + \frac{1}{2} \text{var}(x) + \frac{1}{10} \text{var}(s) \quad (3.31)$$

Given this loss function the central bank tries to stabilize inflation with highest priority, followed by output and by stock prices with least priority.

On the other hand, we also vary the set of interactive channels that are operating: we start with no channels, continue with all possible pairs of two channels of opposite direction, and end by activating all channels simultaneously. The resulting optimal values  $(\delta_\pi^*, \delta_x^*)$  are given in table 3.2.

The first interesting result is that, if the central bank additionally aims to stabilize financial markets, it should less strongly react to variations in inflation  $(\delta_\pi^*)$  while reaction to

<sup>24</sup>Estimation of ACE models is relatively involved so that we have to leave this issue for future research. Compare Franke (2009) and Franke and Westerhoff (2012) on the estimation of ACEs.

Table 3.2: Optimal simple rules for different channels and objective functions.

Parameterization of channels:  $\kappa = 0.100$ ,  $h = 0.500$ ,  $c_1 = 0.200$ ,  $k = 0.200$ .

| Channels    | Real Market           |                     | Real & Fin. Market    |                     |
|-------------|-----------------------|---------------------|-----------------------|---------------------|
| none        | $\delta_\pi^* = 3.47$ | $\delta_x^* = 1.29$ | $\delta_\pi^* = 3.47$ | $\delta_x^* = 1.29$ |
| I & II      | $\delta_\pi^* = 3.44$ | $\delta_x^* = 1.28$ | $\delta_\pi^* = 3.42$ | $\delta_x^* = 1.28$ |
| IIIa & II   | $\delta_\pi^* = 3.18$ | $\delta_x^* = 1.25$ | $\delta_\pi^* = 3.16$ | $\delta_x^* = 1.25$ |
| I & IIIb    | $\delta_\pi^* = 3.45$ | $\delta_x^* = 1.27$ | $\delta_\pi^* = 3.43$ | $\delta_x^* = 1.27$ |
| IIIa & IIIb | $\delta_\pi^* = 3.26$ | $\delta_x^* = 1.27$ | $\delta_\pi^* = 3.24$ | $\delta_x^* = 1.27$ |
| all         | $\delta_\pi^* = 3.10$ | $\delta_x^* = 1.18$ | $\delta_\pi^* = 3.06$ | $\delta_x^* = 1.18$ |

variations in output is unchanged. This result is closer examined in table 3.3 which shows the percentage change in both, the policy coefficients ( $\delta_\pi^*$ ,  $\delta_x^*$ ) and in the volatility measures ( $\text{var}(\pi)$ ,  $\text{var}(x)$ ,  $\text{var}(s)$ ) that occur in the OSR if the CB minimizes  $L_{r+f}$  instead of  $L_r$ . For all channel parameterizations, the CB achieves a decrease in the volatility of  $x$  and  $s$  by accepting an increase in  $\text{var}(\pi)$ . The reason is that both channels (II & IIIb) that affect the financial sector are directly related to the output gap  $x$ . Stabilizing  $x$  therefore also indirectly stabilizes the financial market. This explains the CB's higher interest for output stabilization (which also decreases  $\text{var}(s)$ ).

To bring these results about, the CB has to lessen its reaction towards inflation (decrease in  $\delta_\pi^*$ ; table 3.2, second column) no matter which channels are active. The change in optimal reaction towards output is ambiguous: If the strongly destabilizing channel I (compare section 3.4) is active,  $\delta_x^*$  increases (table 3.2, third column). If channel IIIb (that weakly stabilizes the real sector; sec. 3.4) is active,  $\delta_x^*$  is decreased instead. This change in optimal reaction parameters, however, is very small and irrelevant for most practical considerations.

Table 3.3: Percentage change in OSR policy coefficients and in volatility measures if CB switches from  $L_r$  to  $L_{r+f}$ .

| Channels    | Policy Coefficients |              | Volatility Measures |                 |                 |
|-------------|---------------------|--------------|---------------------|-----------------|-----------------|
|             | $\delta_\pi^*$      | $\delta_x^*$ | $\text{var}(\pi)$   | $\text{var}(x)$ | $\text{var}(s)$ |
| none        | 0.00%               | 0.00%        | 0.00%               | 0.00%           | 0.00%           |
| I & II      | -0.56%              | +0.05%       | +0.46%              | -0.50%          | -0.08%          |
| IIIa & II   | -0.60%              | +0.41%       | +0.51%              | -0.53%          | -0.08%          |
| I & IIIb    | -0.58%              | -0.04%       | +0.47%              | -0.51%          | -0.08%          |
| IIIa & IIIb | -0.55%              | -0.12%       | +0.40%              | -0.43%          | -0.07%          |
| all         | -1.39%              | +0.40%       | +1.14%              | -1.18%          | -0.37%          |

Another robust finding is, that the central bank's reaction becomes weaker, the more interactive channels exist. Policy reaction is strongest, if no channel is active at all. If two channels of opposite direction are added, the policy reaction becomes weaker. If all channels are active simultaneously, the central bank's intervention is decreased further. This is not caused by the interactive channels alone stabilizing the economy and making stabilization

policy by the CB superfluous. On contrast, the loss values monotonically increase the more channels are taken into account (compare first column of tab. 3.4). Instead, the interactive channels make the economy harder to control, therefore CB policy is less efficient and has to be reduced. This finding is robust across both objective functions ( $L_r$  and  $L_{r+f}$ ) as well as different weights<sup>25</sup> within the objective function.

### 3.5.2 History-dependent or Forward-looking?

It is known that an inverse relationship exists between the forward-/backward-lookingness of optimal monetary policy and that of the underlying model: The more forward-looking the model becomes, the more backward-looking monetary policy should be and vice versa.<sup>26</sup>

Our boundedly rational model was originally composed in a forward-looking way (eq. (3.6) and (3.5)). However, the boundedly rational character of expectations makes the model depending on past variables (eq. (3.18)) and therefore backward-looking. The question therefore arises whether monetary policy should optimally be forward- or backward-looking, or something in between.

To answer this question, we derive the (expected) loss values  $L_r$  that correspond to the optimal simple rule under three different scenarios: In scenario one, monetary policy depends on expectations only (compare eq. (3.7)):

$$i_q = \delta_\pi \left( \tilde{\mathbb{E}}_q [\pi_{q+1}] - \pi^* \right) + \delta_x \tilde{\mathbb{E}}_q [x_{q+1}] + \epsilon_q^i$$

In the second scenario it depends on contemporaneous values

$$i_q = \delta_\pi (\pi_q - \pi^*) + \delta_x x_q + \epsilon_q^i \quad (3.32)$$

and in a third one it depends on the most recent past:

$$i_q = \delta_\pi (\pi_{q-1} - \pi^*) + \delta_x x_{q-1} + \epsilon_q^i \quad (3.33)$$

The resulting minimal loss values  $L_r$  are given in table 3.4. The alternative loss definition  $L_{r+f}$  is given in parenthesis. In analogy to the previous subsection we report values for different sets of interactive channels.

Smallest loss values result if monetary policy reacts to contemporaneous values of output and inflation. If it reacts to agent's expectations instead, loss values increase by about 50%. This result is again robust across all combinations of interactive channels and different loss functions. If policy becomes backward-looking, the loss value increases dramatically in the case of no interaction between the financial and real sector. If interaction is taken into account, the model even becomes explosive (i.e.  $L_r \rightarrow \infty$  and  $L_{r+f} \rightarrow \infty$ ).

<sup>25</sup>If we change, for example, the weight of output stabilization from  $\frac{1}{2}$  to 1 (compare Wollmershäuser (2006)), our results remain qualitatively identical.

<sup>26</sup>This issue has been extensively discussed in macroeconomics. Consult, for example, Svensson (1997), Carlstrom and Fuerst (2000), Benhabib et al. (2003), Svensson and Woodford (2003), Eusepi (2005) and Leitemo (2008).

Table 3.4: Comparison of minimal loss values  $L_r$  for forward-looking, contemporaneous and backward-looking optimal simple rules. Loss values  $L_{r+f}$  in parentheses.

| Channels    | Policy Rule depending on                       |               |   |  |
|-------------|--|---------------|---|--|
|             | $\tilde{E}_q[\pi_{q+1}], \tilde{E}_q[x_{q+1}]$ | $\pi_q, x_q$  | $\pi_{q-1}, x_{q-1}$                          |  |
| none        | 0.086 (0.090)                                  | 0.039 (0.043) | 2.60 (2.61)                                   |  |
| I & II      | 0.088 (0.093)                                  | 0.041 (0.046) | $\rightarrow \infty$ ( $\rightarrow \infty$ ) |  |
| IIIa & II   | 0.090 (0.094)                                  | 0.039 (0.044) | $\rightarrow \infty$ ( $\rightarrow \infty$ ) |  |
| I & IIIb    | 0.088 (0.092)                                  | 0.040 (0.044) | $\rightarrow \infty$ ( $\rightarrow \infty$ ) |  |
| IIIa & IIIb | 0.087 (0.091)                                  | 0.039 (0.043) | $\rightarrow \infty$ ( $\rightarrow \infty$ ) |  |
| all         | 0.093 (0.098)                                  | 0.041 (0.046) | $\rightarrow \infty$ ( $\rightarrow \infty$ ) |  |

The standard results, mentioned in the beginning of this subsection, are generally confirmed in our boundedly rational NKM: The model is *de facto* backward-looking. Therefore, monetary policy should depend on information as recent as possible. Since computation of rational expectations is (by assumption) not possible, the most up-to-date information the CB can use is given by contemporaneous values. An interesting new aspect is that wrongly conducted (backward-looking) monetary policy could cause high volatility (large loss values) although it is strictly rule-based. In the presence of financial markets, such policy could even create explosive behavior.

To verify these results, we compare the system matrices of the real market subsystem ( $h = c_1 = 0$ ) for the three policy rules (3.7), (3.32) and (3.33). All system matrices are time dependent. E.g. for rule (3.7) the system matrix is given by  $\mathbf{A}_q^{-1}\mathbf{C}_q$  with  $\mathbf{A}_q$  and  $\mathbf{C}_q$  defined in eq. (3.18).<sup>27</sup> In each time step  $q$  the fractions of agents  $\omega_q^{y,j}$  using the different heuristics (i.e. the state of the learning algorithm; (3.15) and (3.16)) are determined by recent economic development. To get an idea of how often the learning algorithm creates instabilities, we calculate the eigenvalues [EV] of  $\mathbf{A}_q^{-1}\mathbf{C}_q$  for 47916 different realizations over the entire possible range of learning states. In figure 3.5 we report the percentage of learning states that result in an unstable system matrix. Obviously, the probability of becoming explosive is much lower for Taylor rules depending on contemporaneous or expected future values of  $\pi$  and  $x$ . If the central bank reacts to past values, we observe an increase from about 5% to 55%.

As a second verification, we introduce persistence (interest rate smoothing) into the Taylor rule

$$i_q = \eta i_{q-1} + (1 - \eta) \left\{ \delta_\pi \left( \tilde{E}_q[\pi_{q+1}] - \pi^* \right) + \delta_x \tilde{E}_q[x_{q+1}] \right\} + \epsilon_q^i \quad (3.34)$$

where  $\eta \in (0, 1)$  determines the degree of persistence or smoothness.<sup>28</sup> In figure 3.6 we illustrate the (expected) loss value  $L_r$  as a function of  $\eta$  for different interactive channels. Smallest loss values result for  $\eta \in (0, 0.2)$ . For higher  $\eta$  we find exponentially increasing losses.

<sup>27</sup>Compare appendices 3.8.3 and 3.8.4 for system matrices of rules (3.32) and (3.33).

<sup>28</sup>This approach is common in the literature. Consult e.g. Clarida et al. (1998) and Clarida et al. (1999).

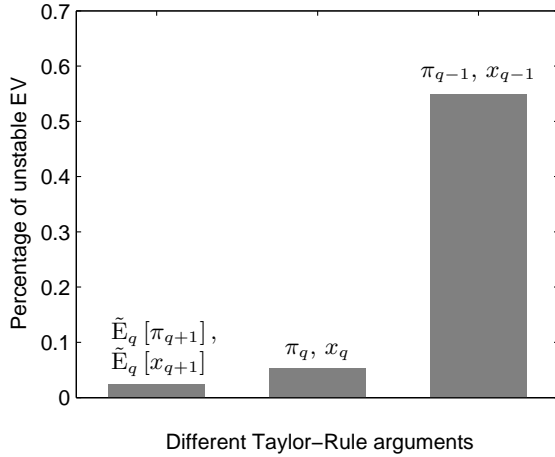

Figure 3.5: Stability of system matrix  $\mathbf{A}_q^{-1}\mathbf{C}_q$  for different Taylor arguments

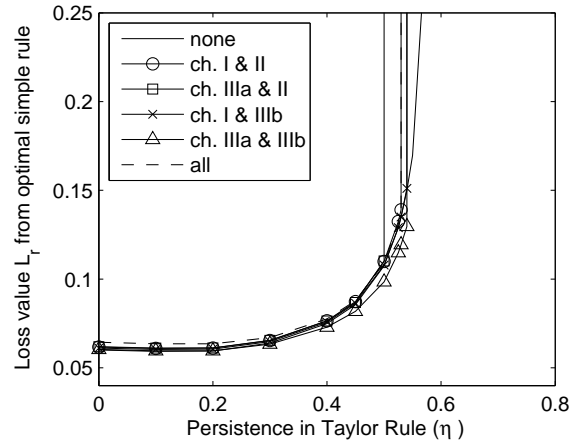

Figure 3.6: Effect of interest rate persistence

The result, that backward-looking monetary policy destabilizes the economy is therefore again confirmed. If a financial sector is active, losses even approach infinity.

As a third verification, we follow Naimzada and Pireddu (2013) by checking if, in a bifurcation plot<sup>29</sup>, the system loses stability earlier if the TR depends on  $\pi_{q-1}$  and  $x_{q-1}$ . Exemplary<sup>30</sup>, we show the bifurcation plots of  $\alpha_\pi$  (compare eq. (3.14) ) in figure 3.7 for the three different Taylor rules (3.7), (3.32) and (3.33). For rules depending on expected and contemporaneous values (panel (a) and (b)) the system loses the unique steady state at  $\alpha_\pi \approx 1.8$ . If monetary policy becomes backward-looking (panel (c)) the first bifurcation takes place already at  $\alpha_\pi \approx 0.37$ .

### 3.5.3 Optimal Unconventional Monetary Policy

Another question that has been debated in the literature<sup>31</sup> on optimal monetary policy is, whether or not the CB should react to over-/under-valuation of financial assets (i.e. bubbles). This is typically done by adding a stock price reaction term to the Taylor rule, e.g.  $+\delta_s \cdot s_q$ . Of course, we could proceed in a similar way and simply derive the optimal  $\delta_s^*$ . But the results of Wollmershäuser (2006) who uses a similar<sup>32</sup> NKM without bounded rationality already suggest that such a welfare increase takes place but is very small.

In light of the policy recently performed by central banks in several advanced countries, we are going to analyze a slightly different question. Instead of reacting with the conven-

<sup>29</sup>In the bifurcation plots we show the long run developments of the deterministic core, i.e. all stochastic terms are set to  $\epsilon_q^i = \epsilon_q^x = \epsilon_q^\pi = \epsilon_t^s = 0 \quad \forall q, t$ .

<sup>30</sup>A bifurcation analysis for all relevant parameters can be found in appendix 3.8.5. Here, we consider  $\alpha_\pi$  only, because all other parameters do not give rise to bifurcations, except for  $\alpha_x$ , which produces very similar results to  $\alpha_\pi$  (compare fig. 3.10 in appendix).

<sup>31</sup>Rudebusch (2005), Kontonikas and Ioannidis (2005), Wollmershäuser (2006), Kontonikas and Montagnoli (2006) and Castelnovo and Nistico (2010).

<sup>32</sup>The model of Wollmershäuser consists of the typical three equation NKM extended by a nominal exchange rate, where the development of nominal exchange rates is modeled in several alternative ways. In one case it is given by a simplified chartist-fundamentalist model (eq. (3.4) and footnote 6) similar to our stock market.

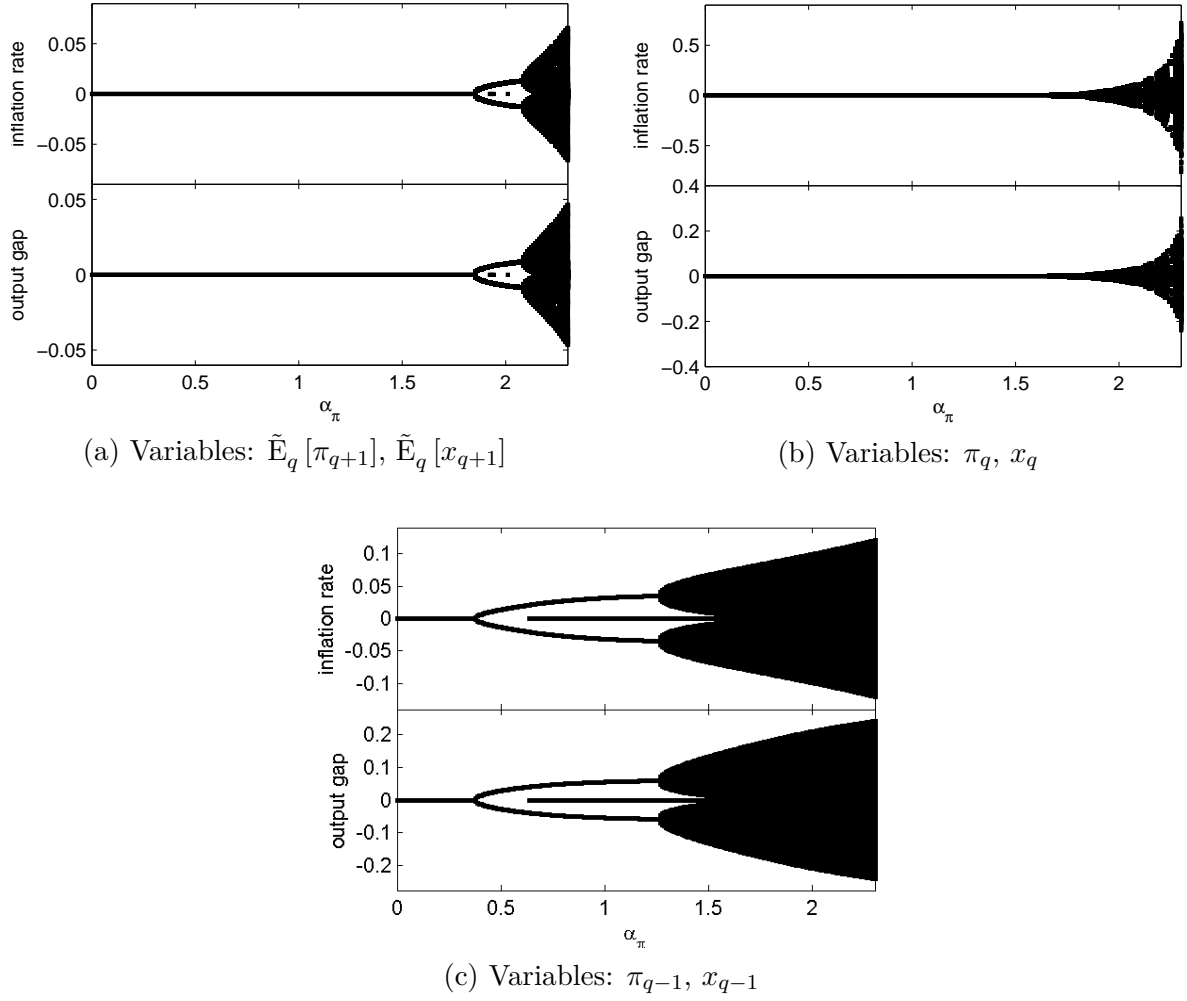

Figure 3.7: Bifurcation plot of parameter  $\alpha_\pi$  for different monetary policy rules depending on different variables

tional instrument only (i.e. the interest rate), we equip the CB with another, *unconventional* instrument (i.e. direct purchases of financial assets) and derive the optimal mixture of both.

If the CB's direct purchases (given by  $\Delta d_q^{CB}$ ) are added to the price impact function (3.26) in just the same way as the excess demand of households, we get:

$$s_{t+1} = s_t + a \left( W_t^C D_t^C + W_t^F D_t^F + \frac{k}{64} \cdot \{ \Delta d_q + \Delta d_q^{CB} \} \right) + \epsilon_t^s \quad (3.35)$$

The first (conventional) instrument is given by eq. (3.7) while for the second (unconventional) we assume that direct purchases are proportional to stock price misalignment:

$$\begin{aligned} \text{Conventional instrument:} \quad i_q &= \delta_\pi (\tilde{E}_q[\pi_{q+1}] - \pi^*) + \delta_x \tilde{E}_q[x_{q+1}] + \epsilon_q^i \\ \text{Unconventional instrument:} \quad \Delta d_t^{CB} &= \delta_s^d \cdot (s_t - s^f) \end{aligned} \quad (3.36)$$

If, for example, the CB buys assets when prices are undervalued and sells when they are overvalued, we have  $\delta_s^d < 0$ . The optimal (simple) mixture of conventional and unconventional

instruments is then defined as (compare (3.29)):

$$(\delta_\pi^*, \delta_x^*, \delta_s^{d,*}) = \arg \min_{\delta_\pi, \delta_x, \delta_s^d} L_j \quad j \in \{r, r+f\} \quad (3.37)$$

The results of the optimization problem (3.37) for conventional versus unconventional policy are contrasted in table 3.5. We distinguish between the case where th CB only cares for real sector stability ( $L_r$ ) and the case where it also cares for financial market stability ( $L_{r+f}$ ).

Table 3.5: Conventional versus unconvenventional monetary policy

Parameterization of channels:  $\kappa = 0.1$ ,  $h = 0.5$ ,  $c_1 = 0.2$ ,  $k = 0.2$

| CB Target | Conventional<br>$\delta_x, \delta_\pi$ | Unconventional<br>$\delta_x, \delta_\pi, \delta_s^d$ |
|-----------|--|--|
| $L_r$     | $L_r = 0.064$                          | $L_r = 0.062$  |
| $L_{r+f}$ | $L_{r+f} = 0.069$                      | $L_{r+f} = 0.062$                                    |

As expected, the loss value increases in the case of conventional policy, if  $\text{var}(s)$  is added to the welfare measure. Compared to conventional monetary policy, unconventional policy leads to a welfare gain for both welfare measures. This gain is larger, if financial market stability explicitly enters the loss function. In both cases ( $L_r$  &  $L_{r+f}$ ), however, the gain of using unconventional instruments is very small.

For simplicity we assumed in eq. (3.36) that the CB knows the true fundamental stock price  $s^f$ .<sup>33</sup> In more realistic settings, where the CB also has to form beliefs about the  $s^f$ , welfare gains might be even lower. Furthermore, we did not consider the presence of zero lower bound for the interest rate  $i_q$ . Unconventional instruments might be more influential if the conventional measures fail.

### 3.6 Conclusion

This paper extends the work of Kontonikas and Montagnoli (2006), Bask (2011), Scheffknecht and Geiger (2011), Bask (2011), Westerhoff (2012), Naimzada and Pireddu (2013), and Lengnick and Wohltmann (2013). It combines the macroeconomic BR-NKM of De Grauwe (2010a) with the financial ACE of Westerhoff (2008) by deriving a generalized IS curve that originates from a non-separable utility function including stocks. This approach gives rise to additional completely microfounded interaction channels with the financial sector.

Once the model is set up, we perform a stability analysis with ambiguous results. The cost channel is clearly destabilizing both, the real and financial sector. For the other channels, results either differ for both sectors (i.e. stabilizing one while destabilizing the other) or they change significantly with the opposing channel. In some regimes, the interactive channels strongly feed back on each other and yield explosive dynamics.

We derive optimal monetary policy rules under a set of different regimes. We find that the central bank's response to inflation decreases slightly if financial market stability enters

<sup>33</sup>Recall, that private agents have to form beliefs about  $s^f$ . Compare eq. (3.25).



the central bank's objective function. Another interesting result is that the optimal central bank reaction to deviations of inflation to their target becomes weaker, the higher the degree of interaction between the financial and real sector.

Finally, we test if the standard results that monetary policy should be backward-looking if the system is forward-looking (and vice versa), can be confirmed for our boundedly rational NKM. We have shown that because the backward-looking nature of the expectations algorithm turns the forward-looking model into a backward-looking one, monetary policy should optimally depend on contemporaneous variables. If, instead, the policy rule becomes backward-looking, the economy is strongly destabilized. Additionally we analyze the importance of unconventional monetary policy instruments and find that they increase welfare only marginally in comparison to conventional policy.

While a number of research questions have been answered in this paper, others had to remain open. For example, we did only focus on simple rules when deriving optimal monetary policy. A detailed treatment of optimal unrestricted policy rules in case of boundedly rational expectations should be conducted in future research.

### 3.7 References

- Ahrens, S. and Sacht, S. (2014). Estimating a High-Frequency New-Keynesian Phillips Curve, *Empirical Economics* **46**(2): 607–628.
- Amato, J. D. and Laubach, T. (2003). Rule-of-Thumb Behaviour and Monetary Policy, *European Economic Review* **47**: 791–831.
- Bask, M. (2011). Asset Price Misalignments and Monetary Policy, *International Journal of Finance & Economics* **540**.
- Bauer, C., Grauwe, P. D. and Reitz, S. (2009). Exchange Rate Dynamics in a Target Zone: A Heterogeneous Expectations Approach, *Journal of Economic Dynamics and Control* **33**(2): 329–344.
- Beja, A. and Goldman, M. B. (1980). On The Dynamic Behavior of Prices in Disequilibrium, *The Journal of Finance* **35**(2): 235–248.
- Benhabib, J., Schmitt-Grohé, S. and Uribe, M. (2003). Backward-Looking Interest-Rate Rules, Interest-Rate Smoothing, and Macroeconomic Instability, *Federal Reserve Bank of Cleveland Journal Proceedings* pp. 1379–1423.
- Bernanke, B. S., Gertler, M. and Gilchrist, S. (1999). *The Financial Accelerator in a Quantitative Business Cycle Framework*, In: Handbook of Macroeconomics, Volume I, Edited by J. B. Taylor and M. Woodford, chapter 21, pp. 1341–1393.
- Brock, W. A. and Hommes, C. H. (1998). Heterogeneous Beliefs and Routes to Chaos in a Simple Asset Pricing Model, *Journal of Economic Dynamics and Control* **22**: 1235–1274.
- Campbell, J. Y., Lo, A. W. and MacKinlay, A. C. (1997). *The Econometrics of Financial Markets*, Princeton University Press.

- Carlstrom, C. and Fuerst, T. S. (2000). Forward-Looking versus Backward-Looking Taylor Rules, *Federal Reserve Bank of Cleveland Working Papers* **0009**: 30.
- Castelnuovo, E. and Nistico, S. (2010). Stock Market Conditions and Monetary Policy in a DSGE Model, *Journal of Economic Dynamics and Control* **34**: 1700–1731.
- Chiarella, C., He, X.-Z. and Hommes, C. (2006). A Dynamic Analysis of Moving Average Rules, *Journal of Economic Dynamics and Control* **30**(9-10): 1729–1753.
- Clarida, R., Gali, J. and Gertler, M. (1998). Monetary Policy Rules in Practice: Some International Evidence, *European Economic Review* **42**: 1033–67.
- Clarida, R., Gali, J. and Gertler, M. (1999). The Science of Monetary Policy: A New Keynesian Perspective, *Journal of Economic Literature* **4**: 1661–1707.
- De Grauwe, P. (2010a). Animal Spirits and Monetary Policy, *Economic Theory* **47**: 423–457.
- De Grauwe, P. (2010b). The Scientific Foundation of Dynamic Stochastic General Equilibrium (DSGE) Models, *Public Choice* **144**: 413–443.
- De Grauwe, P. (2010c). Top-Down versus Bottom-Up Macroeconomics, *CESifo Working Paper* **3020**.
- De Grauwe, P. and Grimaldi, M. (2005). Heterogeneity of Agents, Transactions Costs and the Exchange Rate, *Journal of Economic Dynamics and Control* **29**(4): 691–719.
- De Grauwe, P. and Grimaldi, M. (2006). Exchange Rate Puzzles: A Tale of Switching Attractors, *European Economic Review* **50**: 1–33.
- De Grauwe, P. and Kaltwasser, P. R. (2012). Animal Spirits in the Foreign Exchange Market, *Journal of Economic Dynamics and Control* **36**: 1176–1192.
- Dieci, R. and Westerhoff, F. (2010). Heterogeneous Speculators, Endogenous Fluctuations and Interacting Markets: A Model of Stock Prices and Exchange Rates, *Journal of Economic Dynamics and Control* **34**: 743–764.
- Dosi, G., Fagiolo, G. and Roventini, A. (2010). Schumpeter Meeting Keynes: A Policy-Friendly Model of Endogenous Growth and Business Cycles, *Journal of Economic Dynamics and Control* **34**(9): 1748–1767.
- Eusepi, S. (2005). Comparing Forecast-Based and Backward-Looking Taylor Rules: A "Global" Analysis, *Federal Reserve Bank of New York Staff Reports* **198**: 42.
- Franke, R. (2009). Applying the Method of Simulated Moments to Estimate a small Agent-based Asset Pricing Model, *Journal of Empirical Finance* **16**: 804–815.
- Franke, R. and Sacht, S. (2014). Some Observations in the High-Frequency Versions of a Standard New-Keynesian Model, *Bulletin of Economic Research* **66**(1): 72–94.
- Franke, R. and Westerhoff, F. (2012). Structural Stochastic Volatility in Asset Pricing Dynamics: Estimation and Model Contest, *Journal of Economic Dynamics and Control* **36**(8): 1193–1211.

- Gali, J. (2008). *Monetary Policy, Inflation, and the Business Cycle*, Princeton University Press.
- Kontonikas, A. and Ioannidis, C. (2005). Should Monetary Policy Respond to Asset Price Misalignments?, *Economic Modelling* **22**: 1105–1121.
- Kontonikas, A. and Montagnoli, A. (2006). Optimal Monetary Policy and Asset Price Misalignments, *Scottish Journal of Political Economy* **53**: 636–654.
- Leitemo, K. (2008). Inflation-Targeting Rules: History-Dependence or Forward-Looking?, *Economic Letters* **100**: 267–270.
- Lengnick, M. (2013). Agent-Based Macroeconomics: A Baseline Model, *Journal of Economic Behavior & Organization* **86**: 102–120.
- Lengnick, M. and Wohltmann, H.-W. (2013). Agent-Based Financial Markets and New Keynesian Macroeconomics: A Synthesis, *Journal of Economic Interaction and Coordination* **8**(1): 1–32.
- Matheson, T. (2011). Taxing Financial Transactions: Issues and Evidence, *IMF Working Paper* **54**.
- Menz, J.-O. (2008). Behavioral Macroeconomics and the New Keynesian Model, *Working paper of the Macroeconomics and Finance Series, University of Hamburg* p. 24.
- Minsky, H. P. (1986). *Stabilizing an Unstable Economy*, Yale University Press.
- Naimzada, A. K. and Pireddu, M. (2013). Dynamic Behavior of Real and Stock Markets with Varying Degree of Interaction, *DEMS Working Paper* **245**: 17 pages.
- Ravn, M. O., Schmitt-Grohe, S., Uribe, M. and Uuskula, L. (2010). Deep habits and the dynamic effects of monetary policy shocks, *Journal of the Japanese and International Economies* **24**: 236–258.
- Rudebusch, G. D. (2005). Monetary Policy and Asset Price Bubbles, *Federal Reserve Bank of San Francisco Economic Letter* **5**.
- Samanidou, E., Zschischang, E., Stauffer, D. and Lux, T. (2007). Agent-based Models of Financial Markets, *Reports on Progress in Physics* **70**: 409–450.
- Scheffknecht, L. and Geiger, F. (2011). A Behavioral Macroeconomic Model with Endogenous Boom-Bust Cycles and Leverage Dynamics, *Discussion Paper, University of Hohenheim* .
- Smets, F. and Wouters, R. (2007). Shocks and Frictions in US Business Cycles: A Bayesian DSGE Approach, *The American Economic Review* **97**: 586–606.
- Svensson, L. E. O. (1997). Inflation Forecast Targeting: Implementing and Monitoring Inflation Targets, *European Economic Review* **41**(6): 1111–1146.
- Svensson, L. E. O. (2003). What Is Wrong with Taylor Rules? Using Judgment in Monetary Policy through Targeting Rules, *Journal of Economic Literature* **41**(2): 426–477.
- Svensson, L. E. and Woodford, M. (2003). chapter Implementing Optimal Policy through Inflation-Forecast Targeting, pp. 19–92.

Tramontana, F., Westerhoff, F. and Gardini, L. (2013). The Bull and Bear Market Model of Huang and Day: Some Extensions and New Results, *Journal of Economic Dynamics and Control* **37**(11): 2351–2370.

Westerhoff, F. (2008). The Use of Agent-Based Financial Market Models to Test the Effectiveness of Regulatory Policies, *Jahrbücher für Nationalökonomie und Statistik (Journal of Economics and Statistics)* **228**: 195–227.

Westerhoff, F. (2012). Interactions between the Real Economy and the Stock Market: A Simple Agent-Based Approach, *Discrete Dynamics in Nature and Society* **504840**: 21 pages.

Westerhoff, F. H. and Dieci, R. (2006). The Effectiveness of Keynes-Tobin Transaction Taxes When Heterogeneous Agents Can Trade in Different Markets: A Behavioral Finance Approach, *Journal of Economic Dynamics and Control* **30**: 293–322.

Wollmershäuser, T. (2006). Should Central Banks React to Exchange Rate Movements? An Analysis of the Robustness of Simple Rules under Exchange Rate Uncertainty, *Journal of Macroeconomics* **28**: 493–519.

## 3.8 Appendix

### 3.8.1 Microfoundation of IS Curve with SINU Approach

The household's period utility is determined by (3.1)-(3.3) and reads

$$U(C_q, D_q, N_q) = \frac{Z_q^{1-\sigma}}{1-\sigma} - \frac{N_q^{1+\eta}}{1+\eta} \quad (3.38)$$

$$\text{with: } Z_q = \left[ \alpha_1 C_q^{1-\nu} + \alpha_2 D_q^{1-\nu} \right]^{\frac{1}{1-\nu}} \quad (0 < \alpha_1, \alpha_2 < 1) \quad (3.39)$$

$$\text{s.t. } C_q + \frac{S_q D_q}{P_q} + \frac{T_q^n}{P_q} + \frac{B_q}{P_q} = \frac{W_q}{P_q} N_q + \left( \tilde{d}_{q-1} + S_{q-1} \right) \frac{D_{q-1}}{P_q} + (1 + i_{q-1}) \frac{B_{q-1}}{P_q} \quad (3.40)$$

$$C_q = \underbrace{-\frac{S_q D_q}{P_q} - \frac{T_q^n}{P_q} - \frac{B_q}{P_q} + \frac{W_q}{P_q} N_q + \left( \tilde{d}_{q-1} + S_{q-1} \right) \frac{D_{q-1}}{P_q} + (1 + i_{q-1}) \frac{B_{q-1}}{P_q}}_{=: Y_q} \quad (3.41)$$

The partial derivatives of  $U$  and  $Z$  are:

$$\frac{\partial U}{\partial Z_q} = Z_q^{-\sigma} \quad \frac{\partial Z}{\partial C_q} = \alpha_1 Z_q^\nu C_q^{-\nu} \quad \frac{\partial Z}{\partial D_q} = \alpha_2 Z_q^\nu D_q^{-\nu} \quad (3.42)$$

$$\frac{\partial U}{\partial C_q} = \frac{\partial U}{\partial Z_q} \frac{\partial Z_q}{\partial C_q} = \alpha_1 Z_q^{\nu-\sigma} C_q^{-\nu} \quad \frac{\partial U}{\partial D_q} = \frac{\partial U}{\partial Z_q} \frac{\partial Z_q}{\partial D_q} = \alpha_2 Z_q^{\nu-\sigma} D_q^{-\nu} \quad (3.43)$$

An infinitely lived household maximizes the expected infinite sum of a discounted utility stream for  $q = 0, 1, \dots, \infty$ . The Lagrangian of the given optimization problem reads:

$$\ell = \mathbb{E}_q \left[ \sum_{k=0}^{\infty} \beta^k \{U(C_{q+k}, D_{q+k}, N_{q+k}) + \lambda_{q+k}(Y_{q+k} - C_{q+k})\} \right] \quad (3.44)$$

$$\text{FOC 1: } \frac{\partial \ell}{\partial C_q} = \frac{\partial U}{\partial C_q} - \lambda_q \stackrel{!}{=} 0 \quad \Leftrightarrow \quad \lambda_q = \frac{\partial U}{\partial C_q} = \alpha_1 Z_q^{\nu-\sigma} C_q^{-\nu} \quad (3.45)$$

$$\text{FOC 2: } \frac{\partial \ell}{\partial B_q} = -\lambda_q \frac{1}{P_q} + \beta(1+i_q) \cdot \mathbb{E}_q \left[ \frac{\lambda_{q+1}}{P_{q+1}} \right] \stackrel{!}{=} 0 \quad (3.46)$$

Plugging FOC 1 into FOC 2 yields the Euler equation

$$\alpha_1 Z_q^{\nu-\sigma} C_q^{-\nu} \frac{1}{P_q} = \beta \alpha_1 (1+i_q) \cdot \mathbb{E}_q \left[ \frac{Z_{q+1}^{\nu-\sigma} C_{q+1}^{-\nu}}{P_{q+1}} \right] \quad (3.47)$$

$$\beta \cdot \mathbb{E}_q \left[ \left( \frac{Z_{q+1}}{Z_q} \right)^{\nu-\sigma} \left( \frac{C_{q+1}}{C_q} \right)^{-\nu} \left( \frac{P_q}{P_{q+1}} \right) \right] = \frac{1}{1+i_q} \quad (3.48)$$

$$\text{FOC 3: } \frac{\partial \ell}{\partial D_q} = \frac{\partial U}{\partial D_q} + \lambda_q \frac{\partial Y_q}{\partial D_q} + \beta \mathbb{E}_q \left[ \lambda_{q+1} \frac{\partial Y_{q+1}}{\partial D_q} \right] \stackrel{!}{=} 0 \quad (3.49)$$

$$\Leftrightarrow \alpha_2 Z_q^{\nu-\sigma} D_q^{-\nu} - \alpha_1 Z_q^{\nu-\sigma} C_q^{-\nu} \frac{S_q}{P_q} + \beta \alpha_1 \mathbb{E}_q \left[ \frac{Z_{q+1}^{\nu-\sigma} C_{q+1}^{-\nu}}{P_{q+1}} \right] (\tilde{d}_q + S_q) = 0 \quad (3.50)$$

$$\Leftrightarrow \alpha_2 Z_q^{\nu-\sigma} D_q^{-\nu} + \beta \alpha_1 \mathbb{E}_q \left[ \frac{Z_{q+1}^{\nu-\sigma} C_{q+1}^{-\nu}}{P_{q+1}} \right] (\tilde{d}_q + S_q) = \alpha_1 Z_q^{\nu-\sigma} C_q^{-\nu} \frac{S_q}{P_q} \quad (3.51)$$

$$\Leftrightarrow \frac{\alpha_2}{\alpha_1} \left( \frac{D_q}{C_q} \right)^{-\nu} + \beta \mathbb{E}_q \left[ \left( \frac{Z_{q+1}}{Z_q} \right)^{\nu-\sigma} \left( \frac{C_{q+1}}{C_q} \right)^{-\nu} \frac{1}{P_{q+1}} \right] (\tilde{d}_q + S_q) = \frac{S_q}{P_q} \quad (3.52)$$

$$\Leftrightarrow \frac{\alpha_2}{\alpha_1} \left( \frac{D_q}{C_q} \right)^{-\nu} \frac{P_q}{S_q} + \frac{\tilde{d}_q + S_q}{S_q} \underbrace{\beta \mathbb{E}_q \left[ \left( \frac{Z_{q+1}}{Z_q} \right)^{\nu-\sigma} \left( \frac{C_{q+1}}{C_q} \right)^{-\nu} \frac{P_q}{P_{q+1}} \right]}_{\frac{1}{1+i_q}} = 1 \quad (3.53)$$

$$\Leftrightarrow \frac{\alpha_2}{\alpha_1} \left( \frac{D_q}{C_q} \right)^{-\nu} = \frac{S_q}{P_q} \left[ 1 - \frac{\tilde{d}_q + S_q}{S_q} \frac{1}{1+i_q} \right] \quad (3.54)$$

$$\Leftrightarrow \frac{\alpha_2}{\alpha_1} \left( \frac{D_q}{C_q} \right)^{-\nu} = \frac{S_q}{P_q} \left[ \frac{S_q i_q - \tilde{d}_q}{S_q (1+i_q)} \right] \quad (3.55)$$

$$\Leftrightarrow \left( \frac{D_q}{C_q} \right)^{-\nu} = \frac{\alpha_1}{\alpha_2} \frac{1}{P_q} \left[ \frac{S_q i_q - \tilde{d}_q}{1+i_q} \right] \quad (3.56)$$

In the most simple case, the stock price  $s_q$  should relate to the discounted sum of future dividends (compare Campbell et al. (1997) chapter 7 for this equation and more general

versions):

$$s_q = \sum_{k=0}^{\infty} \tilde{\beta}^k E_q [\tilde{d}_{q+k}] \quad (3.57)$$

For the sake of simplicity we do not model the expectation of future dividends  $E_q [\tilde{d}_{q+k}]$  in a way similar to the boundedly rational expectations (3.12)-(3.11) but simply assume static expectations

$$E_q [\tilde{d}_{q+k}] = \tilde{d}_q \quad \forall k = 0, 1, \dots \quad (3.58)$$

which imply for (3.57)

$$s_q = \tilde{d}_q \frac{1}{1 - \tilde{\beta}} \quad (3.59)$$

$$\Gamma s_q = \tilde{d}_q \quad \text{with: } \Gamma = 1 - \tilde{\beta} \quad (3.60)$$

For the size of  $\Gamma$  there are three cases worth mentioning. First, in the case of riskless dividend streams and zero inflation (i.e. the central bank's target  $i^* = 0$  always fulfilled),  $\tilde{\beta}$  should be equal to the discount factor in the utility function (3.38) and  $\Gamma$  would be less than  $\bar{i}$  because:

$$\tilde{\beta} = \beta : \quad (\Gamma =) \quad 1 - \beta < \frac{1}{\beta} - 1 \quad (= \bar{i}) \quad \Leftrightarrow \quad (3.61)$$

$$1 - \beta < \frac{1 - \beta}{\beta} \quad \Leftrightarrow \quad (3.62)$$

$$(1 - \beta)\beta < 1 - \beta \quad \Leftrightarrow \quad (3.63)$$

$$\beta < 1 \quad \text{holds by assumption} \quad (3.64)$$

This implies  $\bar{i} - \Gamma > 0$ . Given the standard parameterization of  $\beta$  we have numerically  $\bar{i} - \Gamma \approx 0.0001$ . Second, in the case of risky dividend payments agents will discount dividend payments stronger than the save interest payments from bonds (still no inflation risk) and the discount factor  $\tilde{\beta}$  becomes smaller than  $\beta$  which implies  $\bar{i} - \Gamma < 0$ . In the third case, where inflation risk is taken into account, agents could discount payments from stocks less than from bonds which yields  $\bar{i} - \Gamma > 0$ . We focus on the last case because  $\bar{i} - \Gamma < 0$  would lead to a negative radicand in expression (3.103) and (3.104) and therefore to output levels  $x_q$  being complex numbers.

We substitute  $\tilde{d}_q$  in FOC 3 by  $\Gamma s_q^f$  (where  $\Gamma$  depends on the strength of discounting of bond yields compared to stock yields) to arrive at:

$$\left(\frac{D_q}{C_q}\right)^{-\nu} = \frac{\alpha_1}{\alpha_2} \frac{1}{P_q} \left[ \frac{S_q(i_q - \Gamma)}{1 + i_q} \right] \quad (3.65)$$

$$= \frac{\alpha_1}{\alpha_2} \frac{S_q}{P_q} \frac{i_q - \Gamma}{1 + i_q} \quad (3.66)$$

Taking logs (small letters denote log values):

$$-\nu[\log D_q - \log C_q] = \log \left\{ \frac{\alpha_1}{\alpha_2} \right\} + \log S_q - \log P_q + \log \left\{ \frac{i_q - \Gamma}{1 + i_q} \right\} \quad (3.67)$$

$$-\nu d_q + \nu c_q = \log \left\{ \frac{\alpha_1}{\alpha_2} \right\} + s_q - p_q + \log \left\{ \frac{i_q - \Gamma}{1 + i_q} \right\} \quad (3.68)$$

$$d_q = c_q - \frac{1}{\nu} \log \left\{ \frac{\alpha_1}{\alpha_2} \right\} - \frac{1}{\nu} (s_q - p_q) - \frac{1}{\nu} \log \left\{ \frac{i_q - \Gamma}{1 + i_q} \right\} \quad (3.69)$$

Note that the expression above is only defined for  $i_q > \Gamma$ .<sup>34</sup> Let

$$f(i_q) := \frac{1}{\nu} \log \left\{ \frac{i_q - \Gamma}{1 + i_q} \right\} \quad (i_q > \Gamma) . \quad (3.70)$$

Then the first order Taylor approximation around the steady state  $\bar{i}$  without the constant term  $f(\bar{i})$  is given by

$$f(i_q) \approx f'(\bar{i}) \cdot (i_q - \bar{i}) \quad (3.71)$$

$$\approx \frac{1}{\nu} \frac{1 + \bar{i}}{\bar{i} - \Gamma} \frac{1 + \bar{i} - (\bar{i} - \Gamma)}{(1 + \bar{i})^2} \cdot (i_q - \bar{i}) \quad (3.72)$$

$$\approx \frac{1}{\nu} \frac{1 + \Gamma}{(\bar{i} - \Gamma)(1 + \bar{i})} \cdot (i_q - \bar{i}) \quad (3.73)$$

Thus a linearization of (3.69) around the steady state yields the log-linear stock demand function

$$d_q \approx c_q - \frac{1}{\nu} (s_q - p_q) - \frac{1}{\nu} \frac{1 + \Gamma}{(\bar{i} - \Gamma)(1 + \bar{i})} \cdot (i_q - \bar{i}) \quad (3.74)$$

<sup>34</sup>If percentage deviations from steady state are used for linearization (instead of a log-linearization approach)  $i_q < \Gamma$  would also be allowed. This linearization, however, would be mathematically more involved.

which was reported in eq. (3.4) in section 3.2. Next, the Euler equation has to be linearized (where we follow Gali (2008)). After rearranging (3.47) a bit

$$\beta \mathbb{E}_q \left[ \left( \frac{Z_{q+1}}{Z_q} \right)^{\nu-\sigma} \left( \frac{C_{q+1}}{C_q} \right)^{\sigma-\nu} \left( \frac{C_q}{C_{q+1}} \right)^\sigma \left( \frac{P_q}{P_{q+1}} \right) \right] = \frac{1}{1+i_q} \quad (3.75)$$

$$\beta(1+i_q) \mathbb{E}_q \left[ \left( \frac{Z_{q+1}}{Z_q} \right)^{\nu-\sigma} \left( \frac{C_q}{C_{q+1}} \right)^{\nu-\sigma} \left( \frac{C_q}{C_{q+1}} \right)^\sigma \left( \frac{P_q}{P_{q+1}} \right) \right] = 1 \quad (3.76)$$

$$\beta(1+i_q) \mathbb{E}_q \left[ \left( \frac{Z_{q+1}}{C_{q+1}} \right)^{\nu-\sigma} \left( \frac{C_q}{Z_q} \right)^{\nu-\sigma} \right] = \mathbb{E}_q \left[ \left( \frac{C_{q+1}}{C_q} \right)^\sigma \underbrace{\left( \frac{P_{q+1}}{P_q} \right)}_{1+\pi_{q+1}} \right] \quad (3.77)$$

we take logs

$$\begin{aligned} \underbrace{\log \beta}_{-\bar{r}} + \underbrace{\log(1+i_q)}_{\approx i_q} + (\nu-\sigma) \mathbb{E}_q [x_{q+1} - c_{q+1}] + (\nu-\sigma)(c_q - x_q) & \quad (3.78) \\ & = \sigma \cdot \mathbb{E}_q [c_{q+1} - c_q] + \underbrace{\log \mathbb{E}_q [1 + \pi_{q+1}]}_{\approx \mathbb{E}_q[\pi_{q+1}]} \end{aligned}$$

and solve for  $c_q$  to arrive at:

$$\sigma c_q = \sigma \mathbb{E}_q [c_{q+1}] - (i_q - \mathbb{E}_q [\pi_{q+1}] - \bar{r}) + (\nu-\sigma) \{ \mathbb{E}_q [c_{q+1} - x_{q+1}] - (c_q - x_q) \} \quad (3.79)$$

$$c_q = \mathbb{E}_q [c_{q+1}] - \frac{1}{\sigma} (i_q - \mathbb{E}_q [\pi_{q+1}] - \bar{r}) + \frac{\nu-\sigma}{\sigma} \{ \mathbb{E}_q [\Delta(c_{q+1} - x_{q+1})] \} \quad (3.80)$$

The expressions  $\mathbb{E}_q [c_{q+1} - x_{q+1}]$  and  $(c_q - x_q)$  can be replaced if we, first, linearize the composite index (3.39) around the steady state

$$dZ_q = \alpha_1 \bar{Z}^\nu \bar{C}^{-\nu} dC_q + \alpha_2 \bar{Z}^\nu \bar{D}^{-\nu} dD_q \quad (3.81)$$

$$\frac{dZ_q}{\bar{Z}} = \alpha_1 \bar{Z}^\nu \bar{C}^{-\nu} \frac{1}{\bar{Z} \bar{C}} dC_q + \alpha_2 \bar{Z}^\nu \frac{1}{\bar{Z} \bar{C}} \bar{D}^{-\nu} dD_q \quad (3.82)$$

$$z_q = \alpha_1 \left( \frac{\bar{C}}{\bar{Z}} \right)^{1-\nu} c_q + \alpha_2 \left( \frac{\bar{D}}{\bar{Z}} \right)^{1-\nu} d_q \quad (3.83)$$

where  $z_q = \frac{dZ_q}{\bar{Z}}$ ,  $c_q = \frac{dC_q}{\bar{C}}$ ,  $d_q = \frac{dD_q}{\bar{D}}$  denote percentage deviations from steady state and  $dZ_q$ ,  $dC_q$ ,  $dD_q$  absolute deviations. The steady state of (3.39) is given by:

$$\bar{Z}^{1-\nu} = \alpha_1 \bar{C}^{1-\nu} + \alpha_2 \bar{D}^{1-\nu} \quad (3.84)$$

$$1 - \alpha_1 \frac{\bar{C}^{1-\nu}}{\bar{Z}^{1-\nu}} = \alpha_2 \frac{\bar{D}^{1-\nu}}{\bar{Z}^{1-\nu}} \quad (3.85)$$



By subtracting (3.83) from  $c_q$

$$c_q - z_q = \left[ 1 - \alpha_1 \left( \frac{\bar{C}}{\bar{Z}} \right)^{1-\nu} \right] c_q - \alpha_2 \left( \frac{\bar{D}}{\bar{Z}} \right)^{1-\nu} d_q \quad (3.86)$$

plugging (3.85) into (3.86)

$$c_q - z_q = \alpha_2 \left( \frac{\bar{D}}{\bar{Z}} \right)^{1-\nu} c_q - \alpha_2 \left( \frac{\bar{D}}{\bar{Z}} \right)^{1-\nu} d_q \quad (3.87)$$

$$= \alpha_2 \left( \frac{\bar{D}}{\bar{Z}} \right)^{1-\nu} (c_q - d_q) \quad (3.88)$$

and plugging (3.74) into (3.88) we arrive at

$$c_q - z_q = \frac{\alpha_2}{\nu} \left( \frac{\bar{D}}{\bar{Z}} \right)^{1-\nu} \left\{ (s_q - p_q) + \frac{1 + \Gamma}{(\bar{i} - \Gamma)(1 + \bar{i})} \cdot (i_q - \bar{i}) \right\} \quad (3.89)$$

which implies for the expected change of  $c_q - z_q$ :

$$\mathbb{E}_q [\Delta(c_{q+1} - z_{q+1})] = \mathbb{E}_q [c_{q+1} - z_{q+1}] - (c_q - z_q) \quad (3.90)$$

$$= \frac{\alpha_2}{\nu} \left( \frac{\bar{D}}{\bar{Z}} \right)^{1-\nu} \left\{ \mathbb{E}_q [\Delta(s_{q+1} - p_{q+1})] + \frac{1 + \Gamma}{(\bar{i} - \Gamma)(1 + \bar{i})} \cdot \mathbb{E}_q [\Delta i_{q+1}] \right\} \quad (3.91)$$

Equation (3.80) then becomes

$$c_q = \mathbb{E}_q [c_{q+1}] - \frac{1}{\sigma} (i_q - \mathbb{E}_q [\pi_{q+1}] - \bar{r}) + \frac{\nu - \sigma}{\sigma} \frac{\alpha_2}{\nu} \left( \frac{\bar{D}}{\bar{Z}} \right)^{1-\nu} \cdot \left\{ \mathbb{E}_q [\Delta(s_{q+1} - p_{q+1})] + \frac{1 + \Gamma}{(\bar{i} - \Gamma)(1 + \bar{i})} \cdot \mathbb{E}_q [\Delta i_{q+1}] \right\} \quad (3.92)$$

or, if simplified further

$$c_q = \mathbb{E}_q [c_{q+1}] - \frac{1}{\sigma} (i_q - \mathbb{E}_q [\pi_{q+1}] - \bar{r}) + c_1 \cdot \mathbb{E}_q [\Delta(s_{q+1} - p_{q+1})] + c_2 \cdot \mathbb{E}_q [\Delta i_{q+1}] \quad (3.93)$$

with  $c_1 = \frac{\nu - \sigma}{\sigma} \frac{\alpha_2}{\nu} \left( \frac{\bar{D}}{\bar{Z}} \right)^{1-\nu}$  and  $c_2 = c_1 \cdot \frac{1 + \Gamma}{(\bar{i} - \Gamma)(1 + \bar{i})}$ . We can identify  $\left( \frac{\bar{D}}{\bar{Z}} \right)^{1-\nu}$  by first rewriting (3.84) to

$$\frac{\bar{Z}^{1-\nu}}{\bar{D}^{1-\nu}} = \alpha_1 \frac{\bar{C}^{1-\nu}}{\bar{D}^{1-\nu}} + \alpha_2 \quad (3.94)$$

and then rewriting (3.66) to get:

$$\left(\frac{\bar{D}}{\bar{C}}\right)^{1-\nu} = \left(\frac{\alpha_1 \bar{S} \bar{i} - \Gamma}{\alpha_2 \bar{P} 1 + \bar{i}}\right)^{\frac{1-\nu}{\nu}} \quad (3.95)$$

$$\left(\frac{\bar{C}}{\bar{D}}\right)^{1-\nu} = \left(\frac{\alpha_1 \bar{S} \bar{i} - \Gamma}{\alpha_2 \bar{P} 1 + \bar{i}}\right)^{\frac{1-\nu}{\nu}} \quad (3.96)$$

Plugging (3.96) into (3.94) we get

$$\frac{\bar{Z}^{1-\nu}}{\bar{D}^{1-\nu}} = \alpha_1 \left(\frac{\alpha_1 \bar{S} \bar{i} - \Gamma}{\alpha_2 \bar{P} 1 + \bar{i}}\right)^{\frac{1-\nu}{\nu}} + \alpha_2 \quad (3.97)$$

$$\left(\frac{\bar{D}}{\bar{Z}}\right)^{1-\nu} = \frac{1}{\alpha_1 \left(\frac{\alpha_1 \bar{S} \bar{i} - \Gamma}{\alpha_2 \bar{P} 1 + \bar{i}}\right)^{\frac{1-\nu}{\nu}} + \alpha_2 \frac{\alpha_1}{\alpha_1}} \quad (3.98)$$

$$\left(\frac{\bar{D}}{\bar{Z}}\right)^{1-\nu} = \frac{1}{\alpha_1 \left[ \left(\frac{\alpha_1}{\alpha_2}\right)^{\frac{1-\nu}{\nu}} \left(\frac{\bar{S} \bar{i} - \Gamma}{\bar{P} 1 + \bar{i}}\right)^{\frac{1-\nu}{\nu}} + \frac{\alpha_2}{\alpha_1} \right]} \quad (3.99)$$

$$\left(\frac{\bar{D}}{\bar{Z}}\right)^{1-\nu} = \frac{1}{\alpha_1 \frac{\alpha_2}{\alpha_1} \left[ \left(\frac{\alpha_2}{\alpha_1}\right)^{-\frac{1}{\nu}} \left(\frac{\bar{S} \bar{i} - \Gamma}{\bar{P} 1 + \bar{i}}\right)^{\frac{1-\nu}{\nu}} + 1 \right]} \quad (3.100)$$

and the constants  $c_1$  and  $c_2$  become:

$$c_1 = \frac{\nu - \sigma}{\sigma} \frac{\alpha_2}{\nu} \frac{1}{\alpha_1 \frac{\alpha_2}{\alpha_1} \left[ \left(\frac{\alpha_2}{\alpha_1}\right)^{-\frac{1}{\nu}} \left(\frac{\bar{S} \bar{i} - \Gamma}{\bar{P} 1 + \bar{i}}\right)^{\frac{1-\nu}{\nu}} + 1 \right]} \quad (3.101)$$

$$= \frac{\nu - \sigma}{\sigma \nu} \frac{1}{\left(\frac{\alpha_2}{\alpha_1}\right)^{-\frac{1}{\nu}} \left(\frac{\bar{S} \bar{i} - \Gamma}{\bar{P} 1 + \bar{i}}\right)^{\frac{1-\nu}{\nu}} + 1} \quad (3.102)$$

$$= \frac{\nu - \sigma}{\sigma \nu} \frac{\left(\frac{\bar{S} \bar{i} - \Gamma}{\bar{P} 1 + \bar{i}}\right)^{\frac{\nu-1}{\nu}}}{\left(\frac{\alpha_1}{\alpha_2}\right)^{\frac{1}{\nu}} + \left(\frac{\bar{S} \bar{i} - \Gamma}{\bar{P} 1 + \bar{i}}\right)^{\frac{\nu-1}{\nu}}} \quad (3.103)$$

$$c_2 = \frac{\nu - \sigma}{\sigma \nu} \frac{\left(\frac{\bar{S} \bar{i} - \Gamma}{\bar{P} 1 + \bar{i}}\right)^{\frac{\nu-1}{\nu}}}{\left(\frac{\alpha_1}{\alpha_2}\right)^{\frac{1}{\nu}} + \left(\frac{\bar{S} \bar{i} - \Gamma}{\bar{P} 1 + \bar{i}}\right)^{\frac{\nu-1}{\nu}}} \frac{1 + \Gamma}{(\bar{i} - \Gamma)(1 + \bar{i})} \quad (3.104)$$

To be in line with the notation of (3.7)-(3.6) we drop  $\bar{r}$  in eq. (3.93) so that the nominal interest rate  $i_q$  is now interpreted as the difference to steady state:

$$c_q = \text{E}_q [c_{q+1}] - \frac{1}{\sigma} (i_q - \text{E}_q [\pi_{q+1}]) + c_1 \cdot \text{E}_q [\Delta s_{q+1} - \pi_{q+1}] + c_2 \cdot \text{E}_q [\Delta i_{q+1}] \quad (3.105)$$

In equilibrium, consumption equals production so that  $c_q$  is replaced by output  $x_q$ . Finally, a noise term  $\epsilon_x$  is added and expectations are assumed to be given by the boundedly rational

heuristic  $\tilde{E}_q[\cdot]$ :

$$x_q = E_q[x_{q+1}] - \frac{1}{\sigma}(i_q - E_q[\pi_{q+1}]) + c_1 \cdot E_q[\Delta s_{q+1} - \pi_{q+1}] + c_2 \cdot E_q[\Delta i_{q+1}] + \epsilon_q^x \quad (3.106)$$

With stock demand of period  $q$  given as

$$d_q = x_q - c_3(s_q - p_q) - c_4 i_q \quad \text{with: } c_3 = \frac{1}{\nu}, \quad c_4 = \frac{1}{\nu} \frac{1 + \Gamma}{(\bar{i} - \Gamma)(1 + \bar{i})} \quad (3.107)$$

### 3.8.2 Derive Solution of NKM

The three model equations read

$$i_q = \delta_\pi (\tilde{E}_q[\pi_{q+1}] - \pi_q^*) + \delta_x \tilde{E}_q[x_{q+1}] + \epsilon_q^i \quad (3.108)$$

$$x_q = \tilde{E}_q[x_{q+1}] - \frac{1}{\sigma}(i_q - \tilde{E}_q[\pi_{q+1}]) + c_1 \cdot \tilde{E}_q[\Delta s_{q+1} - \pi_{q+1}] + c_2 \cdot \tilde{E}_q[\Delta i_{q+1}] + \epsilon_q^x \quad (3.109)$$

$$\pi_q = \beta \tilde{E}_q[\pi_{q+1}] + \gamma x_q - \kappa s_q + \epsilon_q^\pi \quad (3.110)$$

where the target inflation level  $\pi^*$  is again set to zero and market expectations are given by

$$\tilde{E}_q[x_{q+1}] = \omega_{x,q}^{\text{tar}} \bar{x} + \omega_{x,q}^{\text{hab}} x_{q-1} + \omega_{x,q}^{\text{ext}} (x_q + \alpha_x \cdot [x_q - x_{q-1}]) \quad (3.111)$$

$$= \omega_{x,q}^{\text{ext}} (1 + \alpha_x) x_q + (\omega_{x,q}^{\text{hab}} - \alpha_x \omega_{x,q}^{\text{ext}}) x_{q-1} \quad (3.112)$$

$$\tilde{E}_q[\pi_{q+1}] = \omega_{\pi,q}^{\text{tar}} \pi^* + \omega_{\pi,q}^{\text{rof}} \pi_{q-1} + \omega_{\pi,q}^{\text{ext}} (\pi_q + \alpha_\pi \cdot [\pi_q - \pi_{q-1}]) \quad (3.113)$$

$$= \omega_{\pi,q}^{\text{ext}} (1 + \alpha_\pi) \pi_q + (\omega_{\pi,q}^{\text{rof}} - \alpha_\pi \omega_{\pi,q}^{\text{ext}}) \pi_{q-1} \quad (3.114)$$

$$\tilde{E}_q[s_{q+1}] = \omega_{s,q}^{\text{tar}} h x_q + \omega_{s,q}^{\text{sta}} s_{q-1} + \omega_{s,q}^{\text{ext}} (s_q + \alpha_s [s_q - s_{q-1}]) \quad (3.115)$$

$$= \omega_{s,q}^{\text{ext}} (1 + \alpha_s) s_q + (\omega_{s,q}^{\text{sta}} - \alpha_s \omega_{s,q}^{\text{ext}}) s_{q-1} + \omega_{s,q}^{\text{tar}} h x_q \quad (3.116)$$

$$\tilde{E}_q[i_{q+1}] = i_q \quad (3.117)$$

where –following Lengnick and Wohltmann (2013) and Westerhoff (2012)– the perceived fundamental value is set to  $s_q^f = h \cdot x_q$ . Plugging (3.108) into (3.109) we get:

$$x_q = \tilde{E}_q[x_{q+1}] - \frac{1}{\sigma} (\delta_\pi \tilde{E}_q[\pi_{q+1}] + \delta_x \tilde{E}_q[x_{q+1}] + \epsilon_q^i - \tilde{E}_q[\pi_{q+1}]) + c_1 \cdot \tilde{E}_q[\Delta s_{q+1} - \pi_{q+1}] + \epsilon_q^x \quad (3.118)$$

$$x_q = \frac{\sigma - \delta_x}{\sigma} \tilde{E}_q[x_{q+1}] + \frac{1 - \delta_\pi - \sigma c_1}{\sigma} \tilde{E}_q[\pi_{q+1}] + c_1 \tilde{E}_q[s_{q+1}] - c_1 s_q + \epsilon_q^x - \frac{1}{\sigma} \epsilon_q^i \quad (3.119)$$

Plugging expectations into (3.119) and (3.110) gives

$$\begin{aligned}
x_q &= \frac{\sigma - \delta_x}{\sigma} \underbrace{\left( \omega_{x,q}^{\text{ext}}(1 + \alpha_x)x_q + (\omega_{x,q}^{\text{hab}} - \alpha_x \omega_{x,q}^{\text{ext}})x_{q-1} \right)}_{\tilde{E}_q[x_{q+1}]} \\
&+ \frac{1 - \delta_\pi - \sigma c_1}{\sigma} \underbrace{\left( \omega_{\pi,q}^{\text{ext}}(1 + \alpha_\pi)\pi_q + (\omega_{\pi,q}^{\text{rof}} - \alpha_\pi \omega_{\pi,q}^{\text{ext}})\pi_{q-1} \right)}_{\tilde{E}_q[\pi_{q+1}]} \\
&+ c_1 \underbrace{\left( \omega_{s,q}^{\text{ext}}(1 + \alpha_s)s_q + (\omega_{s,q}^{\text{sta}} - \alpha_s \omega_{s,q}^{\text{ext}})s_{q-1} + \omega_{s,q}^{\text{tar}}hx_q \right)}_{\tilde{E}_q[s_{q+1}]} - c_1 s_q + \epsilon_q^x - \frac{1}{\sigma}\epsilon_q^i \quad (3.120)
\end{aligned}$$

$$\pi_q = \beta \underbrace{\left( \omega_{\pi,q}^{\text{ext}}(1 + \alpha_\pi)\pi_q + (\omega_{\pi,q}^{\text{rof}} - \alpha_\pi \omega_{\pi,q}^{\text{ext}})\pi_{q-1} \right)}_{\tilde{E}_q[\pi_{q+1}]} + \gamma x_q - \kappa s_q + \epsilon_q^\pi \quad (3.121)$$

After some rearranging

$$\begin{aligned}
&\left( \sigma - (\sigma - \delta_x)\omega_{x,q}^{\text{ext}}(1 + \alpha_x) - \sigma c_1 \omega_{s,q}^{\text{tar}}h \right) x_q - (1 - \delta_\pi - \sigma c_1)\omega_{\pi,q}^{\text{ext}}(1 + \alpha_\pi)\pi_q \\
&= (\sigma - \delta_x)(\omega_{x,q}^{\text{hab}} - \alpha_x \omega_{x,q}^{\text{ext}})x_{q-1} + (1 - \delta_\pi - \sigma c_1)(\omega_{\pi,q}^{\text{rof}} - \alpha_\pi \omega_{\pi,q}^{\text{ext}})\pi_{q-1} \\
&\quad + c_1 \sigma \left( \omega_{s,q}^{\text{ext}}(1 + \alpha_s) - 1 \right) s_q + c_1 \sigma \left( \omega_{s,q}^{\text{sta}} - \alpha_s \omega_{s,q}^{\text{ext}} \right) s_{q-1} + \sigma \epsilon_q^x - \epsilon_q^i \quad (3.122)
\end{aligned}$$

$$-\gamma x_q + \left( 1 - \beta \omega_{\pi,q}^{\text{ext}}(1 + \alpha_\pi) \right) \pi_q = \beta \left( \omega_{\pi,q}^{\text{rof}} - \alpha_\pi \omega_{\pi,q}^{\text{ext}} \right) \pi_{q-1} - \kappa s_q + \epsilon_q^\pi \quad (3.123)$$

we arrive at the matrix form

$$\mathbf{A}_q \begin{pmatrix} x_q \\ \pi_q \end{pmatrix} = \mathbf{C}_q \begin{pmatrix} x_{q-1} \\ \pi_{q-1} \end{pmatrix} + \mathbf{D}_q \cdot s_q + \mathbf{E}_q \cdot s_{q-1} + \begin{pmatrix} \sigma \epsilon_q^x - \epsilon_q^i \\ \epsilon_q^\pi \end{pmatrix} \quad (3.124)$$

with the *time dependent* system matrices:

$$\begin{aligned}
\mathbf{A}_q &= \begin{pmatrix} \sigma - (\sigma - \delta_x)\omega_{x,q}^{\text{ext}}(1 + \alpha_x) - \sigma c_1 \omega_{s,q}^{\text{tar}}h & -(1 - \delta_\pi - \sigma c_1)\omega_{\pi,q}^{\text{ext}}(1 + \alpha_\pi) \\ -\gamma & 1 - \beta \omega_{\pi,q}^{\text{ext}}(1 + \alpha_\pi) \end{pmatrix} \\
\mathbf{C}_q &= \begin{pmatrix} (\sigma - \delta_x)(\omega_{x,q}^{\text{hab}} - \alpha_x \omega_{x,q}^{\text{ext}}) & (1 - \delta_\pi - \sigma c_1)(\omega_{\pi,q}^{\text{rof}} - \alpha_\pi \omega_{\pi,q}^{\text{ext}}) \\ 0 & \beta (\omega_{\pi,q}^{\text{rof}} - \alpha_\pi \omega_{\pi,q}^{\text{ext}}) \end{pmatrix} \\
\mathbf{D}_q &= \begin{pmatrix} c_1 \sigma (\omega_{s,q}^{\text{ext}}(1 + \alpha_s) - 1) \\ -\kappa \end{pmatrix} \quad \mathbf{E}_q = \begin{pmatrix} c_1 \sigma (\omega_{s,q}^{\text{sta}} - \alpha_s \omega_{s,q}^{\text{ext}}) \\ 0 \end{pmatrix}
\end{aligned}$$

Multiplying with  $\mathbf{A}_q^{-1}$  we arrive at the solution:

$$\begin{pmatrix} x_q \\ \pi_q \end{pmatrix} = \mathbf{A}_q^{-1} \mathbf{C}_q \begin{pmatrix} x_{q-1} \\ \pi_{q-1} \end{pmatrix} + \mathbf{A}_q^{-1} \mathbf{D}_q \cdot s_q + \mathbf{A}_q^{-1} \mathbf{E}_q \cdot s_{q-1} + \mathbf{A}_q^{-1} \begin{pmatrix} \sigma \epsilon_q^x - \epsilon_q^i \\ \epsilon_q^\pi \end{pmatrix} \quad (3.125)$$

### 3.8.3 Derive Solution of NKM (Version 2)

In this version, the Taylor rule depends on contemporaneous values. The three model equations are given by:

$$i_q = \delta_\pi (\pi_q - \pi_q^*) + \delta_x x_q + \epsilon_q^i \quad (3.126)$$

$$x_q = \tilde{E}_q [x_{q+1}] - \frac{1}{\sigma} (i_q - \tilde{E}_q [\pi_{q+1}]) + c_1 \cdot \tilde{E}_q [\Delta s_{q+1} - \pi_{q+1}] + c_2 \cdot \tilde{E}_q [\Delta i_{q+1}] + \epsilon_q^x \quad (3.127)$$

$$\pi_q = \beta \tilde{E}_q [\pi_{q+1}] + \gamma x_q - \kappa s_q + \epsilon_q^\pi \quad (3.128)$$

Plugging (3.126) into (3.127) we get:

$$x_q = \tilde{E}_q [x_{q+1}] - \frac{1}{\sigma} \left( \left\{ \delta_\pi \pi_q + \delta_x x_q + \epsilon_q^i \right\} - \tilde{E}_q [\pi_{q+1}] \right) + c_1 \cdot \tilde{E}_q [\Delta s_{q+1} - \pi_{q+1}] + \epsilon_q^x \quad (3.129)$$

$$x_q = \tilde{E}_q [x_{q+1}] + \frac{1}{\sigma} \tilde{E}_q [\pi_{q+1}] - \frac{\delta_\pi}{\sigma} \pi_q - \frac{\delta_x}{\sigma} x_q + c_1 \cdot \tilde{E}_q [\Delta s_{q+1} - \pi_{q+1}] + \epsilon_q^x - \frac{1}{\sigma} \epsilon_q^i \quad (3.130)$$

Plugging in expectations:

$$\begin{aligned} x_q = & \underbrace{\omega_{x,q}^{\text{ext}}(1 + \alpha_x)x_q + (\omega_{x,q}^{\text{hab}} - \alpha_x \omega_{x,q}^{\text{ext}})x_{q-1}}_{\tilde{E}_q [x_{q+1}]} + \frac{1 - \sigma c_1}{\sigma} \underbrace{(\omega_{\pi,q}^{\text{ext}}(1 + \alpha_\pi)\pi_q + (\omega_{\pi,q}^{\text{rof}} - \alpha_\pi \omega_{\pi,q}^{\text{ext}})\pi_{q-1})}_{\tilde{E}_q [\pi_{q+1}]} \\ & - \frac{\delta_\pi}{\sigma} \pi_q - \frac{\delta_x}{\sigma} x_q + c_1 \cdot \underbrace{(\omega_{s,q}^{\text{ext}}(1 + \alpha_s)s_q + (\omega_{s,q}^{\text{sta}} - \alpha_s \omega_{s,q}^{\text{ext}})s_{q-1} + \omega_{s,q}^{\text{tar}} h x_q)}_{\tilde{E}_q [s_{q+1}]} - c_1 s_q + \epsilon_q^x - \frac{1}{\sigma} \epsilon_q^i \end{aligned} \quad (3.131)$$

$$\pi_q = \beta \underbrace{(\omega_{\pi,q}^{\text{ext}}(1 + \alpha_\pi)\pi_q + (\omega_{\pi,q}^{\text{rof}} - \alpha_\pi \omega_{\pi,q}^{\text{ext}})\pi_{q-1})}_{\tilde{E}_q [\pi_{q+1}]} + \gamma x_q - \kappa s_q + \epsilon_q^\pi \quad (3.132)$$

After some rearranging

$$\begin{aligned} & (\sigma - \sigma \omega_{x,q}^{\text{ext}}(1 + \alpha_x) + \delta_x - c_1 \sigma \omega_{s,q}^{\text{tar}} h) x_q - \left[ (1 - \sigma c_1) \omega_{\pi,q}^{\text{ext}}(1 + \alpha_\pi) + \delta_\pi \right] \pi_q \\ & = \sigma (\omega_{x,q}^{\text{hab}} - \alpha_x \omega_{x,q}^{\text{ext}}) x_{q-1} + (1 - \sigma c_1) (\omega_{\pi,q}^{\text{rof}} - \alpha_\pi \omega_{\pi,q}^{\text{ext}}) \pi_{q-1} \\ & \quad + c_1 \sigma (\omega_{s,q}^{\text{ext}}(1 + \alpha_s) s_q + (\omega_{s,q}^{\text{sta}} - \alpha_s \omega_{s,q}^{\text{ext}}) s_{q-1}) - c_1 \sigma s_q + \sigma \epsilon_q^x - \epsilon_q^i \end{aligned} \quad (3.133)$$

$$-\gamma x_q + (1 - \beta \omega_{\pi,q}^{\text{ext}}(1 + \alpha_\pi)) \pi_q = \beta (\omega_{\pi,q}^{\text{rof}} - \alpha_\pi \omega_{\pi,q}^{\text{ext}}) \pi_{q-1} - \kappa s_q + \epsilon_q^\pi \quad (3.134)$$

we arrive at the matrix form

$$\mathbf{A}_q \begin{pmatrix} x_q \\ \pi_q \end{pmatrix} = \mathbf{C}_q \begin{pmatrix} x_{q-1} \\ \pi_{q-1} \end{pmatrix} + \mathbf{D}_q \cdot s_q + \mathbf{E}_q \cdot s_{q-1} + \begin{pmatrix} \sigma \epsilon_q^x - \epsilon_q^i \\ \epsilon_q^\pi \end{pmatrix} \quad (3.135)$$

with the *time dependent* system matrices:

$$\begin{aligned} \mathbf{A}_q &= \begin{pmatrix} \sigma - \sigma\omega_{x,q}^{\text{ext}}(1 + \alpha_x) + \delta_x - \sigma c_1 \omega_{s,q}^{\text{tar}} h & -(1 - \sigma c_1)\omega_{\pi,q}^{\text{ext}}(1 + \alpha_\pi) - \delta_\pi \\ -\gamma & 1 - \beta\omega_{\pi,q}^{\text{ext}}(1 + \alpha_\pi) \end{pmatrix} \\ \mathbf{C}_q &= \begin{pmatrix} \sigma(\omega_{x,q}^{\text{hab}} - \alpha_x\omega_{x,q}^{\text{ext}}) & (1 - \sigma c_1)(\omega_{\pi,q}^{\text{rof}} - \alpha_\pi\omega_{\pi,q}^{\text{ext}}) \\ 0 & \beta(\omega_{\pi,q}^{\text{rof}} - \alpha_\pi\omega_{\pi,q}^{\text{ext}}) \end{pmatrix} \\ \mathbf{D}_q &= \begin{pmatrix} c_1\sigma(\omega_{s,q}^{\text{ext}}(1 + \alpha_s) - 1) \\ -\kappa \end{pmatrix} \quad \mathbf{E}_q = \begin{pmatrix} c_1\sigma(\omega_{s,q}^{\text{sta}} - \alpha_s\omega_{s,q}^{\text{ext}}) \\ 0 \end{pmatrix} \end{aligned}$$

Multiplying with  $\mathbf{A}_q^{-1}$  we arrive at the solution:

$$\begin{pmatrix} x_q \\ \pi_q \end{pmatrix} = \mathbf{A}_q^{-1}\mathbf{C}_q \begin{pmatrix} x_{q-1} \\ \pi_{q-1} \end{pmatrix} + \mathbf{A}_q^{-1}\mathbf{D}_q \cdot s_q + \mathbf{A}_q^{-1}\mathbf{E}_q \cdot s_{q-1} + \mathbf{A}_q^{-1} \begin{pmatrix} \sigma\epsilon_q^x - \epsilon_q^i \\ \epsilon_q^\pi \end{pmatrix} \quad (3.136)$$

### 3.8.4 Derive Solution of NKM (Version 3)

In this version, the Taylor rule depends on past values. The three model equations are given by:

$$i_q = \delta_\pi (\pi_{q-1} - \pi_q^*) + \delta_x x_{q-1} + \epsilon_q^i \quad (3.137)$$

$$x_q = \tilde{\mathbf{E}}_q [x_{q+1}] - \frac{1}{\sigma} (i_q - \tilde{\mathbf{E}}_q [\pi_{q+1}]) + c_1 \cdot \tilde{\mathbf{E}}_q [\Delta s_{q+1} - \pi_{q+1}] + c_2 \cdot \tilde{\mathbf{E}}_q [\Delta i_{q+1}] + \epsilon_q^x \quad (3.138)$$

$$\pi_q = \beta \tilde{\mathbf{E}}_q [\pi_{q+1}] + \gamma x_q - \kappa s_q + \epsilon_q^\pi \quad (3.139)$$

Plugging (3.137) into (3.138) we get:

$$x_q = \tilde{\mathbf{E}}_q [x_{q+1}] - \frac{1}{\sigma} \left( \left\{ \delta_\pi \pi_{q-1} + \delta_x x_{q-1} + \epsilon_q^i \right\} - \tilde{\mathbf{E}}_q [\pi_{q+1}] \right) + c_1 \cdot \tilde{\mathbf{E}}_q [\Delta s_{q+1} - \pi_{q+1}] + \epsilon_q^x \quad (3.140)$$

$$x_q = \tilde{\mathbf{E}}_q [x_{q+1}] + \frac{1}{\sigma} \tilde{\mathbf{E}}_q [\pi_{q+1}] - \frac{\delta_\pi}{\sigma} \pi_{q-1} - \frac{\delta_x}{\sigma} x_{q-1} + c_1 \cdot \tilde{\mathbf{E}}_q [\Delta s_{q+1} - \pi_{q+1}] + \epsilon_q^x - \frac{1}{\sigma} \epsilon_q^i \quad (3.141)$$

Plugging in expectations:

$$\begin{aligned} x_q &= \underbrace{\omega_{x,q}^{\text{ext}}(1 + \alpha_x)x_q + (\omega_{x,q}^{\text{hab}} - \alpha_x\omega_{x,q}^{\text{ext}})x_{q-1}}_{\tilde{\mathbf{E}}_q [x_{q+1}]} + \frac{1 - \sigma c_1}{\sigma} \underbrace{\left\{ \omega_{\pi,q}^{\text{ext}}(1 + \alpha_\pi)\pi_q + (\omega_{\pi,q}^{\text{rof}} - \alpha_\pi\omega_{\pi,q}^{\text{ext}})\pi_{q-1} \right\}}_{\tilde{\mathbf{E}}_q [\pi_{q+1}]} \\ &\quad - \frac{\delta_\pi}{\sigma} \pi_{q-1} - \frac{\delta_x}{\sigma} x_{q-1} + c_1 \underbrace{\left\{ \omega_{s,q}^{\text{ext}}(1 + \alpha_s)s_q + (\omega_{s,q}^{\text{sta}} - \alpha_s\omega_{s,q}^{\text{ext}})s_{q-1} + \omega_{s,q}^{\text{tar}} h x_q \right\}}_{\tilde{\mathbf{E}}_q [s_{q+1}]} \\ &\quad - c_1 \cdot s_q + \epsilon_q^x - \frac{1}{\sigma} \epsilon_q^i \end{aligned} \quad (3.142)$$

$$\pi_q = \beta \underbrace{\left( \omega_{\pi,q}^{\text{ext}}(1 + \alpha_\pi)\pi_q + (\omega_{\pi,q}^{\text{rof}} - \alpha_\pi\omega_{\pi,q}^{\text{ext}})\pi_{q-1} \right)}_{\tilde{\mathbf{E}}_q [\pi_{q+1}]} + \gamma x_q - \kappa s_q + \epsilon_q^\pi \quad (3.143)$$

After some rearranging

$$\begin{aligned} & \sigma \left( 1 - \omega_{x,q}^{\text{ext}}(1 + \alpha_x) - c_1 \omega_{s,q}^{\text{tar}} h \right) x_q - (1 - \sigma c_1) \omega_{\pi,q}^{\text{ext}}(1 + \alpha_\pi) \pi_q \\ & = (\sigma \omega_{x,q}^{\text{hab}} - \sigma \alpha_x \omega_{x,q}^{\text{ext}} - \delta_x) x_{q-1} + \left\{ (1 - \sigma c_1) (\omega_{\pi,q}^{\text{rof}} - \alpha_\pi \omega_{\pi,q}^{\text{ext}}) - \delta_\pi \right\} \pi_{q-1} \\ & \quad + \sigma c_1 \left\{ \omega_{s,q}^{\text{ext}} (1 + \alpha_s) - 1 \right\} s_q + \sigma c_1 \left( \omega_{s,q}^{\text{sta}} - \alpha_s \omega_{s,q}^{\text{ext}} \right) s_{q-1} + \sigma \epsilon_q^x - \epsilon_q^i \end{aligned} \quad (3.144)$$

$$-\gamma x_q + \left( 1 - \beta \omega_{\pi,q}^{\text{ext}}(1 + \alpha_\pi) \right) \pi_q = \beta \left( \omega_{\pi,q}^{\text{rof}} - \alpha_\pi \omega_{\pi,q}^{\text{ext}} \right) \pi_{q-1} - \kappa s_q + \epsilon_q^\pi \quad (3.145)$$

we arrive at the matrix form

$$\mathbf{A}_q \begin{pmatrix} x_q \\ \pi_q \end{pmatrix} = \mathbf{C}_q \begin{pmatrix} x_{q-1} \\ \pi_{q-1} \end{pmatrix} + \mathbf{D}_q \cdot s_q + \mathbf{E}_q \cdot s_{q-1} + \begin{pmatrix} \sigma \epsilon_q^x - \epsilon_q^i \\ \epsilon_q^\pi \end{pmatrix} \quad (3.146)$$

with the *time dependent* system matrices:

$$\begin{aligned} \mathbf{A}_q &= \begin{pmatrix} \sigma - \sigma \omega_{x,q}^{\text{ext}}(1 + \alpha_x) - \sigma c_1 \omega_{s,q}^{\text{tar}} h & -(1 - \sigma c_1) \omega_{\pi,q}^{\text{ext}}(1 + \alpha_\pi) \\ -\gamma & 1 - \beta \omega_{\pi,q}^{\text{ext}}(1 + \alpha_\pi) \end{pmatrix} \\ \mathbf{C}_q &= \begin{pmatrix} \sigma (\omega_{x,q}^{\text{hab}} - \alpha_x \omega_{x,q}^{\text{ext}}) - \delta_x & (1 - \sigma c_1) (\omega_{\pi,q}^{\text{rof}} - \alpha_\pi \omega_{\pi,q}^{\text{ext}}) - \delta_\pi \\ 0 & \beta (\omega_{\pi,q}^{\text{rof}} - \alpha_\pi \omega_{\pi,q}^{\text{ext}}) \end{pmatrix} \\ \mathbf{D}_q &= \begin{pmatrix} c_1 \sigma (\omega_{s,q}^{\text{ext}} (1 + \alpha_s) - 1) \\ -\kappa \end{pmatrix} \quad \mathbf{E}_q = \begin{pmatrix} c_1 \sigma (\omega_{s,q}^{\text{sta}} - \alpha_s \omega_{s,q}^{\text{ext}}) \\ 0 \end{pmatrix} \end{aligned}$$

Multiplying with  $\mathbf{A}_q^{-1}$  we arrive at the solution:

$$\begin{pmatrix} x_q \\ \pi_q \end{pmatrix} = \mathbf{A}_q^{-1} \mathbf{C}_q \begin{pmatrix} x_{q-1} \\ \pi_{q-1} \end{pmatrix} + \mathbf{A}_q^{-1} \mathbf{D}_q \cdot s_q + \mathbf{A}_q^{-1} \mathbf{E}_q \cdot s_{q-1} + \mathbf{A}_q^{-1} \begin{pmatrix} \sigma \epsilon_q^x - \epsilon_q^i \\ \epsilon_q^\pi \end{pmatrix} \quad (3.147)$$

### 3.8.5 Further Comparison with the Original De Grauwe Model

In this section we compare the properties of our real sector submodel (appendix 3.8.2; no extension) to those of the original DeGrauwe model (which was also used in Lengnick and Wohltmann (2013)).

#### Expectations Heuristics

In both, the real and financial subsystem, agents make use of boundedly rational heuristics to form expectations. Unfortunately, those heuristics assumed in De Grauwe (2010a,b,c) and Westerhoff (2008) are of a different character. E.g.: Westerhoff assumes an extrapolation of the recently observed stock price ( $s_t$ ) movement<sup>35</sup> while DeGrauwe simply takes the past

<sup>35</sup>Westerhoff (2008) does only implicitly use expectations formation. Compare Lengnick and Wohltmann (2013), section 2.1.

value as the extrapolators' rule:

$$\text{Westerhoff: } \quad \tilde{E}[s_{t+1}] = s_t + k \cdot (s_t - s_{t-1}) \quad (3.148)$$

$$\text{DeGrauwe: } \quad \tilde{E}[\pi_{q+1}] = \pi_{q-1} \quad (3.149)$$

For consistency, and because  $\tilde{E}[x_{t+1}] = x_{t-1}$  is typically called *static* expectations (instead of extrapolative), we apply

$$\tilde{E}_q^{\text{ext}}[\pi_{q+1}] = \pi_q + \alpha_\pi \cdot [\pi_q - \pi_{q-1}] \quad (3.150)$$

as the extrapolators' heuristic in the real sector. At the same time we keep the static expectations of DeGrauwe

$$\tilde{E}_q^{\text{sta}}[\pi_{q+1}] = \pi_{q-1} \quad (3.151)$$

because they give rise to hybridity (similar to the rule-of-thumb or habit formation arguments). The targeters' rule corresponds to that of fundamentalists in the financial sector:

$$\tilde{E}_q^{\text{tar}}[\pi_{q+1}] = \pi_q^* \quad (3.152)$$

Just as fundamentalists believe that stock prices are going to return to the steady state, targeters believe that inflation is going to return to its steady state.

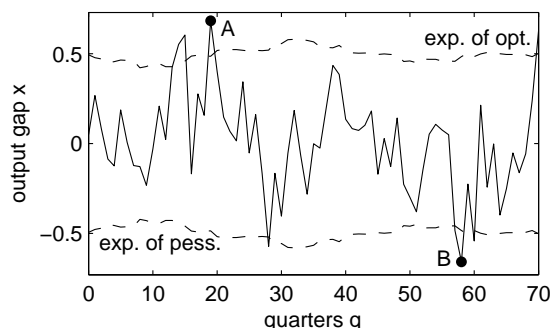

Figure 3.8: Outut gap and its expectations in DeGrauwe NKM

Besides consistency issues, these assumptions also solve a problem that can occur in the original De Grauwe expectations. In his model agents' expectations are either given by a positive (optimists) or a negative value (pessimists).

$$\text{Optimists: } \quad \tilde{E}_q^{\text{opt}}[x_{q+1}] = g_q \quad \text{with: } 2g_q = \mu + \nu \cdot \text{std}[x_q] \quad (3.153)$$

$$\text{Pessimists: } \quad \tilde{E}_q^{\text{opt}}[x_{q+1}] = -g_q \quad \left( = -\tilde{E}_q^{\text{opt}}[x_{q+1}] \right) \quad (3.154)$$

Figure 3.8 illustrates the development of output (solid line) and the corresponding expectations of optimists and pessimists (dashed lines). For the parameterization consult table 3.6. Output fluctuates in a range between -0.6 and 0.6 while expectations are almost constant at -0.5 and 0.5. Sometimes (e.g. point A) we find the somewhat strange result that optimists



expect falling output, a behavior that can hardly be called optimistic any more. Additionally, the pessimists would expect a fall of output from 0.6 down to -0.5. Such a huge change is never observed through the entire series and thus seems a bit too unreasonable to expect. Similar issues can also arise for pessimists (point B). This problem disappears when heuristics (3.9)-(3.14) are applied.

### Bifurcation Analysis

The De Grauwe model does also give rise to bifurcations and stable limit cycles. Bifurcation diagrams of the deterministic core for  $\pi$  and  $x$  with respect to the learning algorithm parameters  $\mu$ ,  $\phi$  and  $\zeta$  are shown in figure 3.9. The corresponding parameterization is given in table 3.6. Small levels of belief bias  $\mu \in (0; 0.575)$  guarantee a unique steady state. At  $\mu = 0.575$  a pitchfork bifurcation takes place and above 1.425 stable limit cycles emerge. Note, however, that these results exploit the problematic expectations heuristic described above.

Table 3.6: Parameterization of original DeGrauwe model

| NKM             | Hybridity     | Policy             | Learning      | Noise                    |
|-----------------|---------------|--------------------|---------------|--------------------------|
| $\sigma = 1.0$  | $\chi = 0.80$ | $\delta_x = 0.5$   | $\zeta = 0.5$ | $\sigma_\epsilon = 0.15$ |
| $\beta = 0.99$  | $\psi = 0.80$ | $\delta_\pi = 1.5$ | $\phi = 10$   |                          |
| $\gamma = 0.33$ |               |                    | $\mu = 0.5$   |                          |
|                 |               |                    | $\nu = 2$     |                          |

The parameter  $\phi$  does not give rise to similar phenomenon while the memory parameter  $\zeta$  gives rise to a bifurcation at  $\zeta = 0.63$ . If agents' memory is very high ( $\zeta \in [0.967, 0.983]$ ), the system displays stable limit cycles on the intervals  $x \in (-0.062, 0.062)$ ,  $\pi \in (-0.15, 0.15)$ . For  $\zeta \in [0.983, 1[$  the system either converges against a positive or a negative steady state, for perfect memory  $\zeta = 1$  the model explodes.

In contrast, our adjusted NKM displays bifurcation and stable limit cycles for the parameters  $\alpha_x$  and  $\alpha_\pi$  (figure 3.10). Like the original De Grauwe model the intensity of choice parameter  $\phi$  does not give rise to any bifurcations. In contrast to De Grauwe our version does also not give rise to bifurcations or limit cycles for high values of the memory parameter. Even for perfect memory  $\zeta = 1$  our model is solvable.

Table 3.7: Parameterization of our model

| NKM             | Hybridity | Policy             | Learning                      | Noise                    |
|-----------------|-----------|--------------------|-------------------------------|--------------------------|
| $\sigma = 1.0$  | -         | $\delta_x = 0.5$   | $\zeta = 0.5$                 | $\sigma_\epsilon = 0.15$ |
| $\beta = 0.99$  |           | $\delta_\pi = 1.5$ | $\phi = 10$                   |                          |
| $\gamma = 0.33$ |           |                    | $\alpha_x = \alpha_\pi = 0.2$ |                          |

### The Special Case of Full Price Flexibility

In NKMs, price stickiness is given by the Calvo parameter  $\theta$ . Perfect price flexibility is archived if  $(1 - \theta) \rightarrow 1$  while for  $\theta \rightarrow 1$  prices are fully rigid. The Calvo parameter is one of

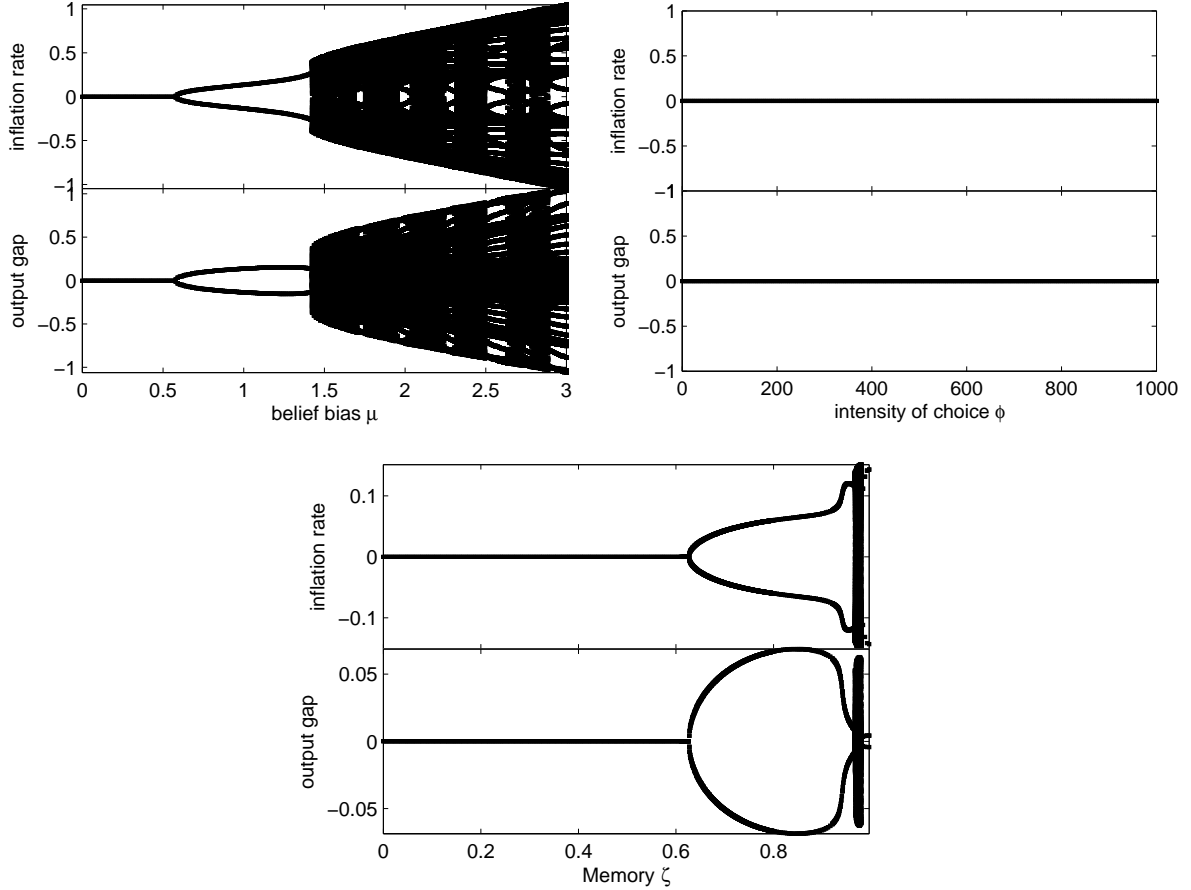

Figure 3.9: Bifurcation plots of original De Grauwe (2010) NKM

the deep parameters that affect  $\gamma$  in the Phillips curve:

$$\gamma = \frac{(1 - \theta)(1 - \beta\theta)}{\theta} \frac{1 - \alpha}{1 - \alpha + \alpha\epsilon} \left( \sigma + \frac{\varphi + \alpha}{1 - \alpha} \right) \quad (3.155)$$

In the following we set  $\alpha = 0$  (constant returns to scale production function),  $\epsilon = 6$  (induces a markup of 20%),  $\varphi = 1.0$  (a unitary Frisch elasticity of labor supply),  $\sigma = 1.0$  (log utility). Compare Gali (2008) on the microfoundation of  $\gamma$  and our parameterization. To test the effect of price flexibility on our model, we vary  $1 - \theta$  on the interval from 0 to 1. The calibration of all other is given in table 3.6 for the original DeGrauwe model and in table 3.7 for our model.

To illustrate the impact of changing price flexibility on the system, we plot the (deterministic) steady state of inflation and output for different values of  $(1 - \theta)$  in figure 3.11. In the original DeGrauwe model (panel (a)), stability of the steady state is only guaranteed for values of  $(1 - \theta)$  up to 0.74. If price flexibility is increased above that value, the model yields explosive dynamics. This problem does not occur in our model (panel (b)). Even for full price flexibility, the model has convergent (i.e. stable) solutions.

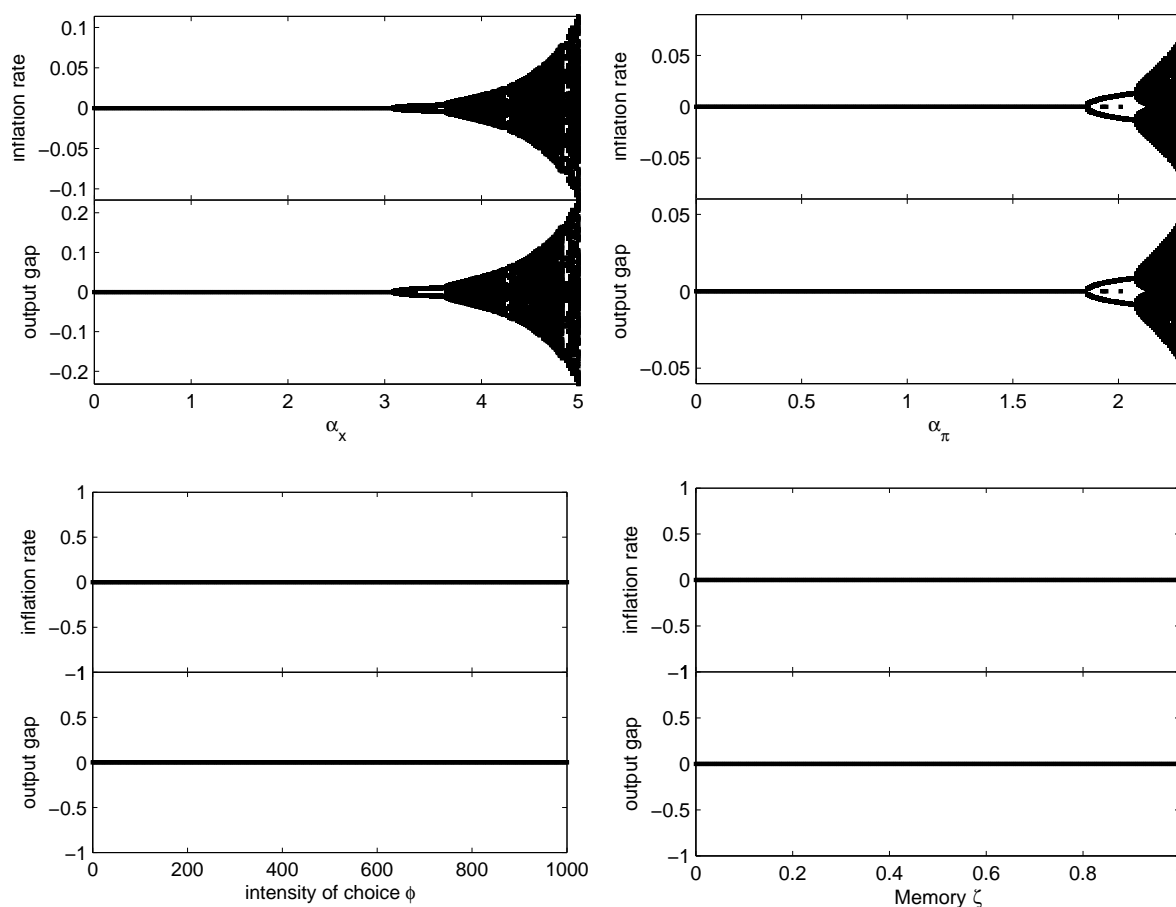
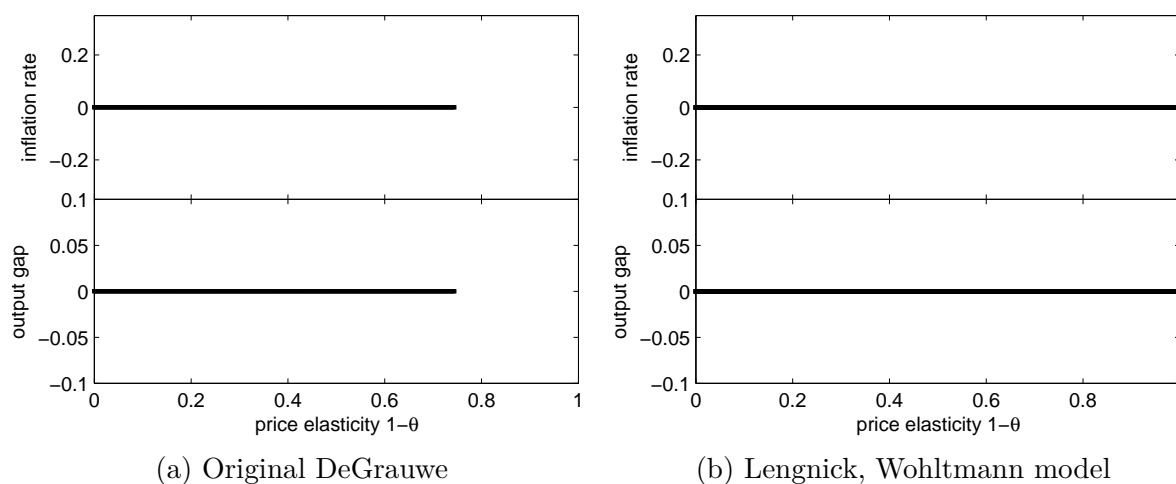

Figure 3.10: Bifurcation plots of adjusted NKM



(a) Original DeGrauwe

(b) Lengnick, Wohltmann model

Figure 3.11: Steady state of deterministic core for different degrees of price flexibility

## Chapter 4

# Agent-Based Macroeconomics: A Baseline Model

*Published in:* Journal of Economic Behavior and Organization, February 2013, Volume 86, pp 102-120

### Abstract

This paper develops a baseline agent-based macroeconomic model and contrasts it with the common dynamic stochastic general equilibrium approach. Although simple, the model can reproduce a lot of the stylized facts of business cycles. The author argues that agent-based modeling is an adequate response to the recently expressed criticism of macroeconomic methodology because it allows for aggregate behavior that is more than simply a replication of microeconomic optimization decisions in equilibrium. At the same time it allows for absolutely consistent micro foundations, including the structure and properties of markets. Most importantly, it does not depend on equilibrium assumptions or fictitious auctioneers and does therefore not rule out coordination failures, instability and crisis by definition. A situation that is very close to a general equilibrium can instead be shown to result endogenously from non-rational micro interaction.

*Keywords:* Agent-based macroeconomics, Complex adaptive systems, Microfoundations, Emergence, Complexity

*JEL classification:* B4, E1, E50

The full article can be downloaded via  
<http://dx.doi.org/10.1016/j.jebo.2012.12.021>

DOI: 10.1016/j.jebo.2012.12.021

## Chapter 5

# Money Creation and Financial Instability: An Agent-Based Credit Network Approach

*Published in:* Economics: The Open-Access, Open-Assessment E-Journal, 2013, Volume 7, Issue 32, pp 1-44

*Coauthored by:* Sebastian Krug, Hans-Werner Wohltmann

### Abstract

We develop a simple agent-based and stock flow consistent model of a monetary economy. Our model is well suited to explain money creation along the lines of mainstream theory. Additionally it uncovers a potential instability that follows from a maturity mismatch of assets and liabilities. We analyze the impact of interbank lending on the stability of the financial sector and find that an interbank market stabilizes the economy during normal times but amplifies systemic instability, contagion and bankruptcy cascades during crises. But even with no interbank market, indirect contagion can lead to bankruptcy cascades. We also find that the existence of large banks threatens stability and that regulatory policy should target large banks more strictly than small.

*Keywords:* Financial instability, agent-based macroeconomics, stock-flow consistency, disequilibrium analysis, Basel III

*JEL classification:* C63, E42, E51, G01

## 5.1 Introduction

The recent crisis has vividly demonstrated that the stability of the banking sector is highly important for the stability of the economy as a whole. A collapse of single banks can have severe and long lasting negative effects on other banks and on the real economy. To shed light on the instability of the banking sector, we develop an agent-based computational economic (ACE) model that covers the monetary side of transactions among households, firms and banks. We are able to show that systemic risk is inevitably interwoven with the creation of money in the credit market and, thus, an intrinsic property of modern economies.

The creation of systemic risk in the banking sector has been subject to numerous research projects in the aftermath of the financial crisis. Battiston et al. (2012) have developed an ACE model of a dynamic credit network. The authors have built on a system of stochastic differential equations and show the existence of a destabilizing financial accelerator. In another related research project Tedeschi et al. (2011) have developed a three sector ACE model that includes the credit sector but also a real sector. The authors have found that credit connections between banks have no impact on GDP but create systemic risk. In line with these findings Lenzu and Tedeschi (2011) have analyzed an interbanking network and have found that the network structure plays an important role for the stability of the system. In a very recent paper, Krause and Giansante (2012) have developed a network based interbanking model and analyzed its stability by letting one bank fail exogenously. They also found that the network structure plays an important role in producing systemic risk and that the probability of observing a cascade is positively correlated with the size of the initially shocked bank.

What is novel in our approach is that individual interactions give endogenously rise to an interconnected banking sector which creates systemic risk and bankruptcy cascades. We show that maturity mismatches (Bank of England 2011, Milne 2013) between different assets and liabilities are a driving force that, first, build up systemic risk and, second, trigger financial crises endogenously. An exogenous depreciation of assets (e.g. burst of bubble) is not needed to trigger a crisis.

In the literature on stock-flow consistent (SFC) modeling it has been argued that the key to understand the recent economic crisis is debt growth. In line with the invocations of Arnold (2009), Bezemer (2010, 2012b) and Caverzasi and Godin (2013) for an *accounting of economics* we implement SFC as the *accounting part* to our model of the credit sector to investigate the potential contribution of SFC to ACE macroeconomics. Formally, we follow the definition of Patterson and Stephenson (1988) whereupon each flow induces a change of stocks of equal size.<sup>1</sup> In an ACE model SFC simply assures that transactions are consistently accounted for in a double-entry bookkeeping system. A difference to “standard” SFC (Lavoie and Zezza 2012) models is that we compute the balance sheet for every single agent (microscopic level) instead of only consolidated balance sheets for every type of agents (aggregate level). Therefore, we can dispense with the usual (consolidated) matrix notation.

---

<sup>1</sup>Consult the definition in Patterson and Stephenson (1988), p. 189. Another, related definition can be found in Taylor (2008).

The paper is organized as follows. Section 5.2 gives a short overview over the current state of ACE macroeconomics. The model is defined in Section 5.3. A simulation that illustrates the endogenous creation of money is performed in Section 5.4. Section 5.5 introduces an interbank market. Simulations of this extended model are presented in Section 5.6. Section 5.7 introduces an active central bank that offers standing facilities and analyzes the impact of regulatory policy. Section 5.8 concludes.

## 5.2 The ACE Method

A method that seems well suited for the analysis of endogenous crises is ACE modeling.<sup>2</sup> ACE models can be understood as the simulation of artificial worlds that are populated by autonomous interacting agents. Every agent is equipped with properties describing his internal state and with behavioral rules that guide its interaction with others. Once created, the artificial economy is left alone and agents interact according to the defined rules. Instead of solving a system of equations, the model is simply run. Aggregate statistics like the price index or GDP can then easily be calculated from the resulting individual dynamics.

One strength of the ACE method is that no assumptions about the macro level are necessary. The passage from micro to macro is created by interaction and not by assuming a representative individual or by summing up heterogeneous individual decisions and equilibrating aggregate supply and demand on *the market* for labor, goods, money and so on. All observed regularities of the aggregate variables are, therefore, endogenously emerging from micro assumptions and micro interactions. With our ACE model we can, thus, analyze the banking sector as a large decentralized economic system. We are able to answer how agents, which are not endowed with unrealistically high information processing capacities (Ackerman (2002), Gaffeo et al. (2008), Fair (2009), Kirman (2010)), can coordinate so well through the market mechanism without any central clearing device or auctioneer and, more importantly, why this coordination brakes down from time to time.

The major weakness of ACE models is that the modeler is left with enormous degrees of freedom in choosing the types of agents, their behavioral rules and the structure of markets. Consequently, the few ACE macro models that exist are very different in nature, since they start with very different assumptions and employ very different ways of modeling. Additionally, it is easy to deal with enormous complexity. ACE modelers are, thus, tempted to over-increase the level of complexity in their models (i.g. add too much types of agents, behavioral rules, special cases for a certain interaction, ... ). As a result, the available ACE macro models are often so complex that it is unclear which macro pattern is a result of what micro property. Models appear as black boxes where the passage from input to output is not fully clear.<sup>3</sup>

---

<sup>2</sup>Axtell (2007), Colander et al. (2008), Keen (2009), Kirman (2010), Delli Gatti et al. (2010).

<sup>3</sup>Fagiolo and Roventini (2012) put it as follows: “*The more one tries to inject into the model ‘realist’ assumptions, the more the system becomes complicate to study and the less clear the causal relations going from assumptions to implications are.*” The authors call this problem *over-parameterization*. They offer a detailed discussion of the pros and cons of ACE and some possible guides to assumption selection that prohibit



In the present paper we address this criticism by keeping the model as simple as possible. The number of different types of agents and different behavioral rules are kept as small as possible. Following Gode and Sunder (2004), Ussher (2008) and Chen (2012) we assume that our agents are of the zero intelligence type (ZIA). This assumption allows to create a benchmark which isolates the effect of market rules on market outcomes independent of the influence of agent's strategic response to new information.

### 5.3 The Model

In this section we present a formal description of our model. Although the following presentation is already very detailed, we have to leave out some minor important aspects that are only intended to make the graphical animation more convenient. The full source code is available upon request. The model description follows the ODD (Overview, Design concepts, Details) protocol.<sup>4</sup>

#### 5.3.1 Overview

##### Purpose

Our aim is to build a very simple model that concentrates on the monetary side of transactions. Although simple, our model creates a complex interrelated network of financial claims. This network of claims necessarily produces inherent instability and the threat of deep crises. Since our model has a natural equilibrium benchmark in standard theory, it is well suited to contrast SFC/ACE models with the mainstream approach.

##### Entities, State Variables and Scales

The artificial environment is populated by three different types of agents: banks (BA), households (HH) and a central bank (CB). HHs in our setting are interpreted as representatives of the complete real sector and, therefore, also have characteristics that are typically ascribed to firms:<sup>5</sup> they buy goods but also produce them, they save but also take loans. We index BAs by the subscript  $b = 1, \dots, B$  and HHs by  $h = 1, \dots, H$  where we set  $B \ll H$ . BAs and HHs are characterized by their positioning on a two dimensional landscape. Space plays a minor role in the model. It is used as a tool to provide random matching and to introduce frictions.

The CB is introduced to close the system from an accounting point of view. For simplicity, we start with assuming that there are no repo operations or standing facilities.

---

over-parameterization.

A similar point is made by Farmer et al. (2012) who argue that the fundamental question for ACE economics is how aggregate macro behavior emerges from heterogeneous interacting individuals at the micro level. This question can be addressed with *stylized* ACE models.

Consult also Caverzasi and Godin (2013) who highlight on the didactical use of *simple* SFC models.

<sup>4</sup>The ODD protocol has been developed to standardize the presentation of ACE models. The full description can be found in Grimm et al. (2010).

<sup>5</sup>Such *yeoman farmer* assumptions are not unusual as a theoretical approximation, e.g. compare the NOEM approach of Obstfeld and Rogoff (1996).

As a result, the CBs' assets are fixed throughout the entire simulation. We denote this exogenously given value by  $A^{cb}$  which can be set to any positive value without changing the simulation results and might be interpreted as gold reserves. These assumptions will be relaxed in Section 5.7.

The most important state variable that characterizes BAs and HHs is *cash* ( $C$ ). It is the only medium of exchange, i.e. all transactions have to be paid with cash. We explicitly model every single agent's balance sheet at every point in time.<sup>6</sup> In this balance sheet  $C$  is recorded on the *assets*' side. Each agent can also possess claims on the cash of other agents. We denote claims of HHs against BAs with  $D$  (for deposits) and claims of BAs against HHs with  $L$  (for loans). Obviously,  $D$  is recorded as an asset in the HHs balance sheet and as liability in that of BAs, *vice versa* for  $L$ . The balance sheet structure is exemplified in Sheets 1 - 3.

| Sheet 1: Example HH $h$  | Sheet 2: Example BA $b$ | Sheet 3: Central Bank (CB) |               |                    |                   |  |  |                 |   |        |             |               |                      |                  |  |                  |                 |  |        |             |                  |                      |  |                         |  |                    |
|--|-------------------------|----------------------------|---------------|--------------------|-------------------|--|--|-----------------|---|--------|-------------|---------------|----------------------|------------------|--|------------------|-----------------|--|--------|-------------|------------------|----------------------|--|-------------------------|--|--------------------|
| <table style="width: 100%; border-collapse: collapse;"> <thead> <tr> <th style="text-align: left; border-bottom: 1px solid black;">Assets</th> <th style="text-align: left; border-bottom: 1px solid black;">Liabilities</th> </tr> </thead> <tbody> <tr> <td style="padding: 2px 5px;">Cash<br/><math>C^h</math></td> <td style="padding: 2px 5px;">Loan Bank<br/><math>L^h</math></td> </tr> <tr> <td style="padding: 2px 5px;">Deposits<br/><math>D^h</math></td> <td style="padding: 2px 5px;"></td> </tr> <tr> <td style="padding: 2px 5px;"></td> <td style="padding: 2px 5px;">Equity<br/><math>E^h</math></td> </tr> </tbody> </table> | Assets                  | Liabilities                | Cash<br>$C^h$ | Loan Bank<br>$L^h$ | Deposits<br>$D^h$ |  |  | Equity<br>$E^h$ | <table style="width: 100%; border-collapse: collapse;"> <thead> <tr> <th style="text-align: left; border-bottom: 1px solid black;">Assets</th> <th style="text-align: left; border-bottom: 1px solid black;">Liabilities</th> </tr> </thead> <tbody> <tr> <td style="padding: 2px 5px;">Cash<br/><math>C^b</math></td> <td style="padding: 2px 5px;">HH Deposits<br/><math>D^b</math></td> </tr> <tr> <td style="padding: 2px 5px;">Reserve<br/><math>R^b</math></td> <td style="padding: 2px 5px;"></td> </tr> <tr> <td style="padding: 2px 5px;">Credits<br/><math>L^b</math></td> <td style="padding: 2px 5px;">Equity<br/><math>E^b</math></td> </tr> </tbody> </table> | Assets | Liabilities | Cash<br>$C^b$ | HH Deposits<br>$D^b$ | Reserve<br>$R^b$ |  | Credits<br>$L^b$ | Equity<br>$E^b$ | <table style="width: 100%; border-collapse: collapse;"> <thead> <tr> <th style="text-align: left; border-bottom: 1px solid black;">Assets</th> <th style="text-align: left; border-bottom: 1px solid black;">Liabilities</th> </tr> </thead> <tbody> <tr> <td style="padding: 2px 5px;">Gold<br/><math>A^{cb}</math></td> <td style="padding: 2px 5px;">Currency<br/><math>C^{cb}</math></td> </tr> <tr> <td style="padding: 2px 5px;"></td> <td style="padding: 2px 5px;">BA Deposits<br/><math>R^{cb}</math></td> </tr> <tr> <td style="padding: 2px 5px;"></td> <td style="padding: 2px 5px;">Equity<br/><math>E^{cb}</math></td> </tr> </tbody> </table> | Assets | Liabilities | Gold<br>$A^{cb}$ | Currency<br>$C^{cb}$ |  | BA Deposits<br>$R^{cb}$ |  | Equity<br>$E^{cb}$ |
| Assets   | Liabilities             |                            |               |                    |                   |  |  |                 |   |        |             |               |                      |                  |  |                  |                 |  |        |             |                  |                      |  |                         |  |                    |
| Cash<br>$C^h$  | Loan Bank<br>$L^h$      |                            |               |                    |                   |  |  |                 |   |        |             |               |                      |                  |  |                  |                 |  |        |             |                  |                      |  |                         |  |                    |
| Deposits<br>$D^h$  |                         |                            |               |                    |                   |  |  |                 |   |        |             |               |                      |                  |  |                  |                 |  |        |             |                  |                      |  |                         |  |                    |
|  | Equity<br>$E^h$         |                            |               |                    |                   |  |  |                 |   |        |             |               |                      |                  |  |                  |                 |  |        |             |                  |                      |  |                         |  |                    |
| Assets   | Liabilities             |                            |               |                    |                   |  |  |                 |   |        |             |               |                      |                  |  |                  |                 |  |        |             |                  |                      |  |                         |  |                    |
| Cash<br>$C^b$  | HH Deposits<br>$D^b$    |                            |               |                    |                   |  |  |                 |   |        |             |               |                      |                  |  |                  |                 |  |        |             |                  |                      |  |                         |  |                    |
| Reserve<br>$R^b$   |                         |                            |               |                    |                   |  |  |                 |   |        |             |               |                      |                  |  |                  |                 |  |        |             |                  |                      |  |                         |  |                    |
| Credits<br>$L^b$   | Equity<br>$E^b$         |                            |               |                    |                   |  |  |                 |   |        |             |               |                      |                  |  |                  |                 |  |        |             |                  |                      |  |                         |  |                    |
| Assets   | Liabilities             |                            |               |                    |                   |  |  |                 |   |        |             |               |                      |                  |  |                  |                 |  |        |             |                  |                      |  |                         |  |                    |
| Gold<br>$A^{cb}$   | Currency<br>$C^{cb}$    |                            |               |                    |                   |  |  |                 |   |        |             |               |                      |                  |  |                  |                 |  |        |             |                  |                      |  |                         |  |                    |
|  | BA Deposits<br>$R^{cb}$ |                            |               |                    |                   |  |  |                 |   |        |             |               |                      |                  |  |                  |                 |  |        |             |                  |                      |  |                         |  |                    |
|  | Equity<br>$E^{cb}$      |                            |               |                    |                   |  |  |                 |   |        |             |               |                      |                  |  |                  |                 |  |        |             |                  |                      |  |                         |  |                    |

Each BA is required to deposit required reserves at the CB (denoted by  $R$ ). Required reserves  $R^b$  are a claim of  $b$  against the CB. We assume that a BA can, immediately and at any height, convert  $R$  into  $C$  and *vice versa*. This assumption accounts for the fact that transactions between private banks and the central bank are carried out much faster and for smaller time horizons (e.g. overnight) than transactions with the real sector. The *liquidity reserves* of BAs are, therefore, given by  $F^b = C^b + R^b$  while those of HHs are given by  $C^h$ . We denote the corresponding CB positions  $C^{cb} + R^{cb}$  the *monetary base* ( $M_B$ ).

For simplicity, we assume that every HH can only have claims against one given BA (this BA is denoted  $b^{D,h}$ ) and only one BA (denoted by  $b^{L,h}$ ) can have claims against him. This simplification reflects the fact that most HHs are customers of a very limited subset of BAs and do not lend money from/to the entire set of BAs.<sup>7</sup> As long as more than one BA exists, we assume  $b^{D,h} \neq b^{L,h}$ , i.e.  $h$  places his deposits and takes credits from different BAs. Otherwise, the two positions  $D$  and  $L$  would partially cancel out against one another. We further assume, for simplicity, that  $b^{D,h}$  and  $b^{L,h}$  do not change during one simulation.

Following the standard financial reporting rules of the FASB<sup>8</sup>, equity positions  $E^b$ ,  $E^h$  and  $E^{cb}$  are given by the residual between assets and liabilities (= net worth). All entries – except

<sup>6</sup>Compare Cincotti et al. (2010) for a detailed description of the implementation of accounting in a large scale ACE model.

<sup>7</sup>Battiston et al. (2012) have noted that credit networks are generally incomplete, i.e. not fully connected (p. 2).

<sup>8</sup>"Equity or net assets is the residual interest in the assets of an entity that remains after deducting its liabilities." (Financial Accounting Standards Board; 1985, p. 21).

for equity – have to fulfill a non-negativity constraint. The sum of all individual changes in assets has to equal that of liabilities. We can use this property to check whether all accounting operations have been performed correctly, i.e. we will check that  $\sum_h dE^h + \sum_b dE^b + dE^{cb} = 0$  in each time step.

For the ease of exposition, we make use of the common assumption that the interest rate equals zero.<sup>9</sup> We further assume that all BAs equity is initially zero ( $E^b = 0 \quad \forall b$ ).  $E^b$  will remain unchanged because the interest rate is assumed to be zero.

### Process Overview and Scheduling

In our setting, time necessarily comes in discrete steps. To come as close as possible to the ideal of continuous time, we scale down the length of these time steps by so much that the model becomes practically continuous. In each (infinitesimal small) time step, the agents are allowed to make decisions and act.

We assume that agents try to achieve a constant ratio between certain positions of their balance sheet, e.g. keep cash in a given relation to deposits. Whenever this relationship is not matched, they take actions in order to reestablish it. In each time step, we check for the state of every agent and assign one mode to it depending on the relations of its balance sheet positions. The mode in turn determines the actions the agent undertakes.

### 5.3.2 Design Concepts

#### Basic Principles

The basic principle underlying our model is the creation of money. If money is defined as the sum of cash and deposits owned by HHs, it is created both by the central bank (via the monetary base) and by the banking sector (via debt/loan contracts). In equilibrium, the money amount is a multiple of the monetary base. This property of money is well known. But instead of simply deriving the equilibrium outcome, we show that the equilibrium-benchmark is the long run result of a disequilibrium process composed of individual interactions.

#### Emergence

We will only model interactions among individuals in an explicit way: for every single transaction, we impose a flow of cash from one specific agent to another. This is also true if a loan is granted from a BA to a HH.<sup>10</sup> Each flow is accounted for in the balance sheets by changing the agents' stocks and maybe creating a claim of one against the other. We do not assume the existence of a credit market with a given set of properties (like equilibrium or monopolistic

<sup>9</sup>This assumption is common in most macroeconomic ACE models, e.g.: see Russo et al. (2007) and Gaffeo et al. (2008) for the rate on savings. It could, however, be interesting for future versions of the model to relax this assumption. E.g. the effects of a positive lending rate on distributional effects between different sectors can be studied in a dynamic context.

<sup>10</sup>Implicitly, we assume here that a HH who picks up a loan receives this loan in cash. Alternatively, one could, at first, increase the HH's deposits and then convert them into cash (which is needed to buy goods). For simplicity, we refrain from the latter method since, although it is equivalent to the first method in the end, it requires more transactions. Additionally, it is unnecessary to invoke transactions between the BA and CB that would be needed to ensure the reserve requirement (defined below).

competition). We can, however, interpret the sum of all individual credit contracts as *the credit market*. This market is an *endogenous* object growing out of individual transactions. It has endogenous properties founded in micro interactions.

### Adaptation

The agents in our model act to achieve a given relation between certain positions in their balance sheet. HHs try to divide their wealth ( $C^h + D^h$ ) into cash and deposits so that they are in a fixed relation to each other. If the wealth of a HH is composed, for example, of a too high share of cash relative to deposits it places further cash in the bank account to match the target relation. BAs are modeled in a similar way. Instead of matching a given  $C$ - $D$ -ratio, they have to provide required reserves  $R^b$  as a given fraction of deposits  $D^b$ .

### Objectives

To keep their behavior as simple as possible, we assume that HHs  $h$  want to divide their wealth up into  $C^h$  and  $D^h$  so that

$$C^h = q \cdot D^h \quad q \in [0, 1] \quad (5.1)$$

holds. Where  $q$  is the cash ratio which, for ease of exposition, we assume to be equal among all HHs. BAs, on the other hand, have to obey a reserve requirement according to

$$R^b = r \cdot D^b \quad r \in [0, 1] \quad (5.2)$$

where  $r$  is the reserve ratio set by the CB. Recall that  $D^b$  is not the aggregate sum of all HHs' deposits but only of that subset of HHs for whom  $b^{D,h} = b$  holds, i.e. sum of all deposits that have been placed at BA  $b$ . Since our model is a disequilibrium model, we do *not assume* that (5.1) and (5.2) hold. Instead, we will define the agents' behavioral rules such that they strive to arrive at those relationships. It might be possible, however (e.g. after a liquidity shock by the CB), that some agents, temporarily, do not meet (5.1) or (5.2), respectively.

### Learning

We do not apply a complicate learning procedure for the agents. Instead, we assume, first, that knowledge is generally local, i.e. agents know their own state variables, but not those of others. Second, since the positioning of banks on the landscape is not changing over time, we assume it to be public knowledge. Therefore, HHs do not need to apply a search mechanism to find a BA.

### Interaction

Interactions always take place between two agents. Every interaction induces a flow of cash from one agent (say A) to another (B): A's cash entry is reduced by a given amount while B's is increased by the same amount. Some transactions (e.g. buying a good) are directly completed

after the flow of cash from A to B. Other types of transactions (e.g. borrowing/lending) consist of the commitment to repay later and, additionally, cause the creation of claims of A against B.

Modeling interactions in such a way assures that all flows between two agents are in line with the change of their stocks (i.e. are SFC<sup>11</sup>). It proves a disciplined way to introduce money into ACE macroeconomics since it obeys a “*fundamental law of macroeconomics analogous to the principle of conservation of energy in physics*”<sup>12</sup>.

### Stochasticity

Whenever agents are satisfied with their current state, they do not initiate transactions, instead, they take a (stochastic) random walk around the landscape. Regarding interactions, we use pseudo random number generators in two ways. (1) When an agent can choose only one partner to interact with, he decides by picking randomly. (2) Whenever a BA has excess reserves ( $C^b > 0$ ), it offers loans of the highest possible amount  $\Delta L^b = \frac{C^b}{1+r}$ . If a HH decides to take a loan from that bank, we determine its demand randomly between the supplied amount  $\frac{C^b}{1+r}$  and a small lower bound value close to zero.

### Observation

When running the model, we keep track of the balance sheet of every single agent. For all positions that denote a claim of one agent against another, we save the amount of that claim and the two involved agents. Given the set of all individual balance sheets and the way they are interwoven with one another, we can also calculate different monetary aggregates as the respective sum of different individual positions.

### 5.3.3 Details

#### Initialization

At the beginning, all HHs are randomly distributed over the landscape, while BAs are placed evenly (Figure 5.1). We initialize all balance sheet entries with zero, i.e. there is no money in the economy.

#### Submodels

A HH’s current state of  $C^h$  and  $D^h$ , straightforwardly, implies three different modes of action:

- HH mode 0 ( $C^h = q \cdot D^h$ ): desired cash quota holds exactly, no action required.
- HH mode 1 ( $C^h < q \cdot D^h$ ): not enough Cash, transform  $D^h$  into  $C^h$ .
- HH mode 2 ( $C^h > q \cdot D^h$ ): too much Cash, transform  $C^h$  into  $D^h$ .

<sup>11</sup>A formal definition of SFC can be found in Patterson and Stephenson (1988) or Taylor (2008).

<sup>12</sup>Godley and Cripps (1983), p. 14. Found in Bezemer (2010), p. 682.

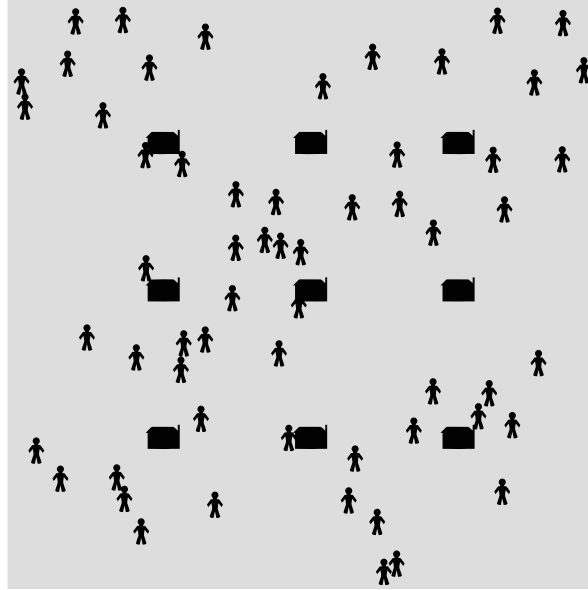

Figure 5.1: Initial distribution of agents in space

If  $C^h = q \cdot D^h$  holds for HH  $h$ , he enters mode 0. In this mode, there is no need for  $h$  to initiate any transaction. We illustrate this mode by a random walk around the landscape. In the case of  $C^h < q \cdot D^h$ , he enters mode 1. The HH then directly walks to BA  $b^{D,h}$  to withdraw deposits until mode 0 holds. If, *vice versa*,  $C^h > q \cdot D^h$  holds (mode 2),  $h$  directly walks to  $b^{D,h}$  to place the excess cash in his bank account, i.e.  $h$  converts  $C^h$  into  $D^h$  until mode 0 holds. A BA never rejects such receipts of liquidity. Figure 5.2 illustrates the decisions of all agents in a flow chart.

Similarly, we define 3 modes for BAs. All modes follow directly from the assumption that each BA  $b$  has to hold required reserves  $R^b$  proportional to the deposits that HHs have placed on bank accounts of  $b$ . The different modes are, thus, given by:

- BA mode 0 ( $F^b = r \cdot D^b$ ): liquidity reserves  $F^b$  (given by  $F^b = C^b + R^b$ ) match target value of required reserves  $r \cdot D^b$ .
- BA mode 1 ( $F^b > r \cdot D^b$ ): too much liquid funds, grant a credit.
- BA mode 2 ( $F^b < r \cdot D^b$ ): not enough liquid funds, withdraw a credit.

If  $b$ 's liquid funds ( $F^b = C^b + R^b$ ) are equal to the reserve requirements,  $b$  holds all liquidity reserves at its account with the CB ( $C^b = 0$  and  $R^b = r \cdot D^b$ ). If eq. (5.2) holds, the bank enters mode 0, and no further transactions with other agents are initiated by  $b$ . If  $b$ 's liquid funds are larger than  $r \cdot D^b$ , the bank holds  $R^b = r \cdot D^b$  at its CB account. The remaining excess reserves are hold in the form of cash ( $C^b > 0$ ) and a loan is offered to real sector agents at the amount of  $\frac{C^b}{1+r}$ .

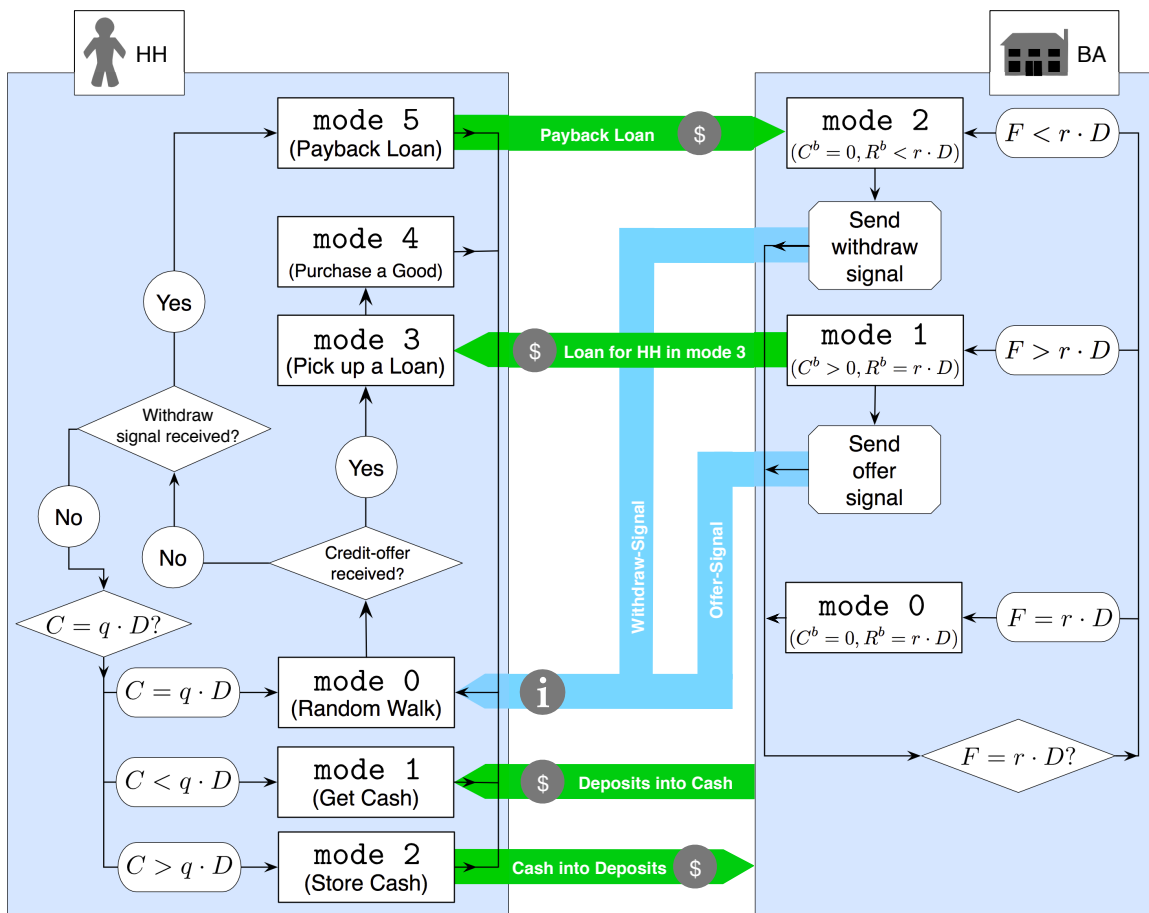

Figure 5.2: Simplified decision structure and interaction of households and banks

If  $F^b < r \cdot D^b$  holds, the bank, first, transfers all liquid funds into  $R^b$ . Second, it withdraws a loan that has been granted to a HH earlier.<sup>13</sup> Practically, this is done by sending a **withdraw credit-signal** to one of the HHs that  $b$  has a claim on and that is currently in mode 0<sup>14</sup>.

We are aware that, in reality, banks can not simply attain any amount of liquidity in the short-run by withdrawing credits because they are, in general, not legally allowed to do so (due to fixed maturities). Additionally, even if they have this opportunity, the borrower might not have enough liquid funds available (standard maturity transformation problem<sup>15</sup>). Thus, banks can only withdraw credits slowly by refusing to renew old ones that became due. This mechanism is proxied by a simpler one in our model: under normal conditions, a loan runs forever. If a bank intends to bring outstanding loans down, it can withdraw loans from only one agent at a time. Additionally, loans are only repaid partially (about 15%, details below). This simplifies our model a lot, since we do not need to integrate all the thousands of loans with an individual duration. For simplicity, we also assume that BAs are not punished by

<sup>13</sup>Recall that all transactions have to be payed with cash.

<sup>14</sup>Withdrawing only from HHs in mode 0 is a non-restrictive assumption. First, because most of the time the majority of HHs are in this mode anyhow and, second, because a HH in another mode will return to mode 0 quickly so that the BA can withdraw credits from it. This assumption prevents that an active HH is interrupted in its current interaction.

<sup>15</sup>Bank of England (2011)

the CB if they are unable to supply the reserve requirements. This assumption is relaxed in Section 5.7.

The three modes we have introduced for the HHs above do not yet allow to take and repay a loan. We, therefore, have to add three additional modes to close the credit circle.

- HH mode 3: pick up a loan from  $b^{L,h}$ .
- HH mode 4: use loan to buy a good from another HH.
- HH mode 5: **withdraw credit**-signal received.

If BA  $b$  offers a loan, one HH of those, who are in mode 0 and for whom  $b^{L,h} = b$  holds, gets informed about the loan offer and enters mode 3. This HH then moves to  $b^{L,h}$  and picks up a loan. We assume that it is offered only to one randomly<sup>16</sup> determined HH at the same time. The amount of that loan ( $\Delta L^h$ ) is also randomly determined between the supply  $\frac{C^b}{1+r}$  and a small lower bound<sup>17</sup>.

After taking a loan, the HH  $h$  uses the new liquidity to purchase a good (mode 4).  $h$  randomly walks around the landscape until it meets some other HH (say  $\bar{h}$ ) who is in mode 0.  $h$  buys a good from  $\bar{h}$  and pays with cash. This transaction is accounted for in the balance sheet of  $h$  as a decrease of cash by  $\Delta L^h$  and an increase of cash in the sheet of  $\bar{h}$ . We are interested in the production and consumption of goods only insofar as it provides a motivation for taking a credit. We, therefore, assume that  $\bar{h}$  produces the good directly before the transaction takes place and  $h$  consumes it directly thereafter. One can think of this as a service (e.g. hair cut). This simplification allows us to neglect the real sector and to keep the flow of goods out of the balance sheets. It seems odd, at first, that HHs take loans to buy goods although they still have money left. Households, however, also represent the firm side of the real sector and with this behavioral assumption, we account for firms' leveraging.<sup>18</sup>

If a HH receives a **withdraw credit**-signal, he enters mode 5 and directly walks to BA  $b^{L,h}$ . Once reached, he transfers cash to the BA until the loan is repaid or until he has no liquid funds left.

## 5.4 The Endogenous Creation of Money

In this section, we are going to analyze how private individuals endogenously create money. We initialize our population as described above with all balance sheet positions set to zero. The parametrization is given by  $H = 60$ ,  $B = 9$ ,  $q = 0.15$  and  $r = 0.04$ . As the initial impulse to the system, we simulate a helicopter drop, i.e. the CB creates 10 units of cash and leaves it to the HHs. For simplicity, we assume that it is completely given to one randomly determined

<sup>16</sup>Technically, we determine the random HH by picking that HH with the highest distance to  $b$ . Since HHs take a random walk, picking the one with highest distance to  $b$  results in a random choice but assures that a HH that just repaid a credit (and thus stands next to  $b$ ) is not directly picked again.

<sup>17</sup>Technically, this lower bound  $L_{\min} = \min\left\{0.01, \frac{C^b}{1+r}\right\}$  is required to assure convergence towards a steady state. When a BA reduces its surplus liquidity, its offered loan contracts are also decreasing. The lower bound assures that a falling  $C^b$  does not generate loan contracts that are also converging towards zero.

<sup>18</sup>To gain further insight into the rationale of borrowing from a management science perspective, see Jensen (1986), Harris and Raviv (1990) or Stulz (1990).



HH. This simplification allows us to focus on one individual agent at the beginning of the simulation since all others remain in mode 0. In later simulations, the helicopter money is distributed among all HHs. Our concept of endogeneity is different from that in the Post-Keynesian tradition where the supply of credit is infinitely elastic and hence no exogenous (helicopter) drop is needed.<sup>19</sup> In the paper at hand, the wider monetary aggregates are produced in an interactive process. Money is, therefore, created by behavioral interactions. In this sense it is *endogenous*.

Sheet 4 and 5 illustrate two individual balance sheets immediately after the helicopter drop. The cash entry of one HH  $h$  is increased by 10 which also increases  $h$ 's equity by 10. In the CBs balance sheet the currency position is increased by 10 which induces a fall in equity by 10.<sup>20</sup> Figure 5.3 illustrates part of the landscape. Each agent in the figure has a subscript showing his two most important assets. These are  $C^h/D^h$  for HHs and  $C^b/R^b$  for BAs.

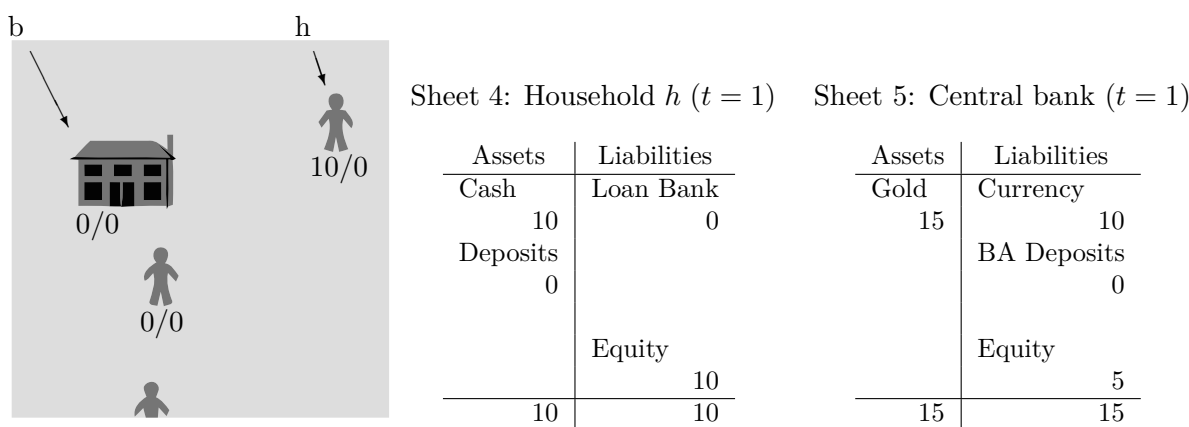

Figure 5.3: Agents at  $t = 1$

In  $t = 1$ , all agents are in mode 0 except for  $h$ . Obviously,  $h$ 's share of cash is too large compared to (5.1). It, therefore, enters mode 2 and walks in the direction of BA  $b^{D,h}$  to place deposits there.<sup>21</sup> After some time steps ( $t = 300$  in our simulation), he reaches  $b^{D,h}$  and places 8.70 units of cash in his bank account to satisfy condition (5.1). His balance sheet undergoes a swap of assets:  $C^h$  is reduced by 8.70, while  $D^h$  is increased by the same amount (Sheet 6). In the balance sheet of bank  $b$ , this transaction induces an increase of cash by 8.70. Now,  $b$  has a too large amount of liquid funds. It enters mode 1 and deposits  $r \cdot 8.70 = 0.35$  units of cash as reserve requirements at the CB (Sheet 7). The remaining liquidity (8.35) is offered as a loan.

The creation of money through lending is obvious from Sheets 4 - 7. While in  $t = 1$  there are 10 units of money among the private agents (the cash of HH  $h$ ), there are 18.5 units in  $t = 300$  ( $1.3+8.7=10$  for HH  $h$  plus 8.35 units of cash for BA  $b$ ).

<sup>19</sup>A Post-Keynesian version of endogenous money in ACE macroeconomic models can be found in Teglio et al. (2012).

<sup>20</sup>We can quickly perform the consistency check mentioned in Section 5.3.1: initially, all agents have zero equity. After the shock, only those of HH  $h$  and the CB change. The sum of all changes in equity in our model, therefore, equals zero because  $10 + (-10) = 0$ .

<sup>21</sup>The helicopter drop applied here is basically in line with the traditional Keynesian theory: surplus liquidity is *not* used to buy goods (e.g. Pigou effect) but financial securities (here: deposits).

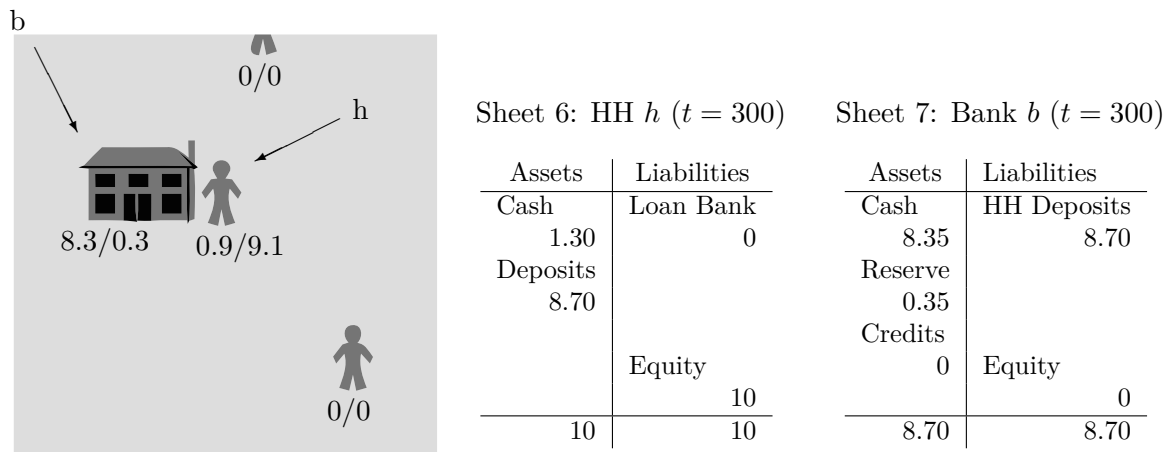

Figure 5.4: Agents at  $t = 300$

We have now described one transaction in full detail. After this one, there are of course millions of other transactions following. While the computer program explicitly models all these transactions in full detail, we can step back and focus our attention on the emergence of aggregate properties. First of all, we look at the endogenous generation of a network of claims. Figure 5.5(a) illustrates BAs as black points and HHs as white circles. The first transaction in  $t = 300$  between  $h$  and  $b$  has created a claim of  $h$  against  $b$ . We illustrate this claim as a link from  $h$  to  $b$ . Since the other agents have not taken/granted a credit yet, they are not connected. A second connection is established as soon as  $b$  uses the excess reserves to grant a loan to another household (e.g.  $\bar{h}$ ), a link from  $b$  to  $\bar{h}$  is created.

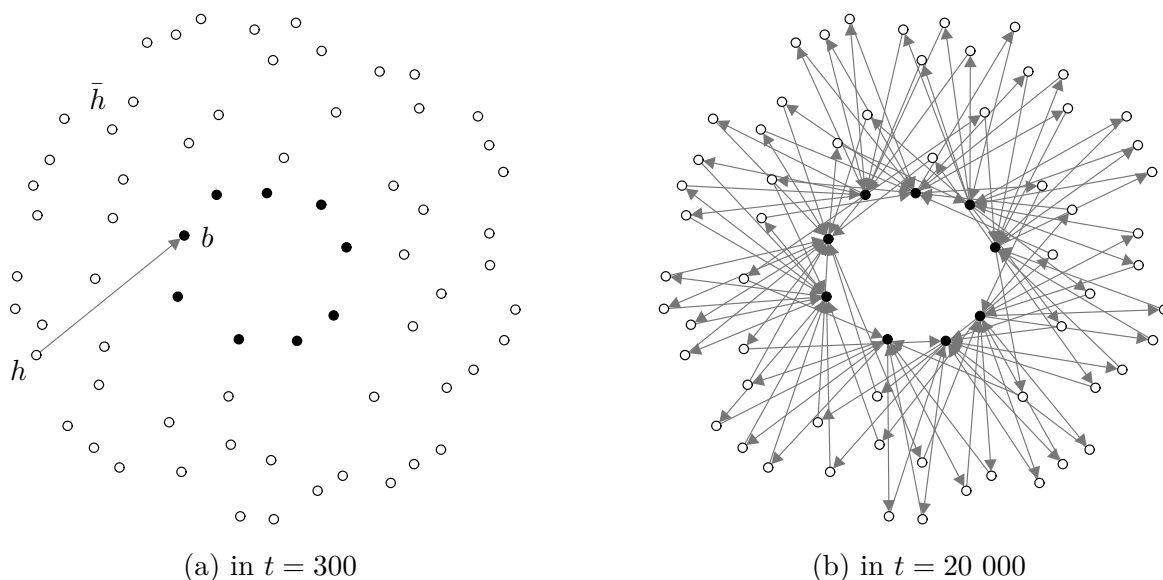

Figure 5.5: Network of claims (black points denote BAs, circles denote HHs, arrows denote claims)

As time goes by, more and more individual transactions are carried out. BAs grant more and more loans to HHs, while HHs increase their possession of deposits. By performing these transactions, the agents endogenously weave a network of claims on each other. At the same time, these transactions endogenously produce money. Figure 5.6 shows the development of

the monetary aggregates over time. BAs transform the monetary base from cash into reserve requirements (left panel). At the same time, HHs transform cash into deposits and, thus, allow banks to grant credits. The additional credits strongly increase  $M_1$  (right panel). The process continues until eq. (5.1) is fulfilled for every HH and (5.2) for every BA. Such a state results – up to a numerical precision of three digits – around  $t = 20\,000$ . The monetary aggregates in this situation are given by  $M_1 \approx 60.53$  and  $L \approx 50.53$ . The market is characterized by a highly entangled network of credit claims (Figure 5.5(b)). In this state, every HH is connected to two BAs ( $b^{D,h}$  and  $b^{L,h}$ ).

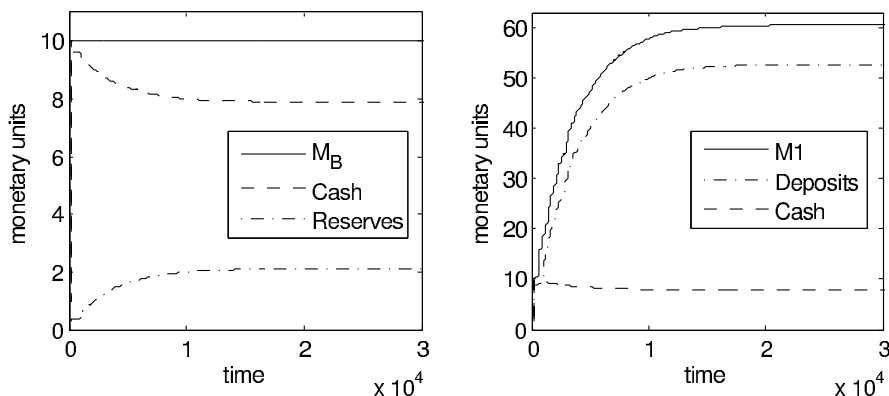

Figure 5.6: Development of monetary aggregates

### Equilibrium Benchmark

The monetary multipliers  $\mu_1$  and  $\mu_L$  that determine the aggregate amount of  $M_1$  and  $L$  in equilibrium are given by<sup>22</sup>

$$M_1^* = \frac{1+q}{q+r} \cdot M_B = \mu_1 \cdot M_B \quad \text{with } \mu_1 > 1 \quad (5.3)$$

$$\text{and } L^* = \frac{1-r}{q+r} \cdot M_B = \mu_L \cdot M_B \quad \text{with } \mu_L > 1 \quad (5.4)$$

For our parametrization, we get  $\mu_1 = 6.053$  and  $\mu_L = 5.053$ . Since the monetary base in our simulation is given by  $M_B = 10$ , the equilibrium values of  $M_1$  and  $L$  are given by  $M_1^* = 60.53$  and  $L^* = 50.53$ .

Although it is not assumed, the economy converges against the theoretical equilibrium ( $M_1^*$  and  $L^*$ ) in the long run. Since the agents in our model are of the ZIA type, this proves that it is the market structure alone (operating in disequilibrium generally) that assures this convergence (compare Section 5.3.1). We also show that, while the economy moves in the direction of  $M_1^*$  and  $L^*$ , it does not only create money but also a strongly interconnected network of claims.

<sup>22</sup>A recent discussion about fractional reserve banking (the cause of the money multiplier) can be found in Mallet (2012).

Now, that we have demonstrated the creation of money and financial interconnections as a product of interaction between HHs and BAs, we can introduce the next dimension of credit markets: interbank lending.

## 5.5 The Interbank Market

To introduce an interbank market for credits, we augment BAs **mode 1** and **mode 2**. If a BA enters **mode 1**, it does, first, offer a credit to other BAs and, second, to HHs. On the other hand, if a BA enters **mode 2**, it first tries to bridge the shortage in liquidity by taking a credit from another BA. If this is not possible, e.g. because no bank has currently a surplus of liquidity, it withdraws a credit from a HH. To account for interbank credits, we have to extend the balance sheet of banks by  $I_+^b$  (interbank receivables) and  $I_-^b$  (interbank liabilities). An example is given in sheet 8.

Sheet 8: Example BA  $b$

| Assets  |         | Liabilities |         |
|---------|---------|-------------|---------|
| Cash    | $C^b$   | HH Deposits | $D^b$   |
| Reserve | $R^b$   | BA Credits  | $I_-^b$ |
| Credits |         | Equity      |         |
| HH      | $L^b$   |             |         |
| BA      | $I_+^b$ |             | $E^b$   |

A credit from one bank (say  $b$ ) to another ( $\bar{b}$ ) is accounted for by a decrease in  $C^b$  and an increase in  $C^{\bar{b}}$ . At the same time, a claim is created by increasing  $I_+^b$  and  $I_-^{\bar{b}}$  by the same amount. In contrast to credits from BAs to HHs, we assume that credits between BAs can be carried out immediately and that they have a fixed repay date ( $t^{\text{repay}} = t + x$ ) in the near future. The maturity  $x$  is randomly determined between 1000 and 2000.<sup>23</sup> This assumption should account for the fact that interbank credits are, typically, granted quicker and over shorter time horizons than credits to the real sector (Cocco et al. (2009), Demiralp et al. (2006)).

The creation of money in the previous section followed a monotonic path, i.e. from the exogenous increase of cash until an equilibrium was reached, the aggregate  $M_1$  was never decreasing. As a result, no HH and no BA has ever encountered a shortage of liquidity (HH **mode 1** and BA **mode 2**). Interbank lending, however, depends on one BA with a surplus and another with a shortage of liquidity *at the same time*. In the following, we extend HHs behavior in the real sector in order to generate such different liquidity endowments for BAs.

First, we assume that HHs, which are satisfied with their financial position (**mode 0**) do not simply stop their economic actions but interact with one another. To introduce such real market interaction between HHs, we change the above definition of HH's **mode 0** in the following way.

<sup>23</sup>Recall, HHs have to walk to their BA (which takes some time) before taking a credit. A fixed repay date is also not set.

- Extended HH mode 0 ( $C^h = q \cdot D^h$ ): buy/sell goods.

As before, a HH  $h$ , for whom  $C^h = q \cdot D^h$  holds, enters mode 0 and takes a random walk around the landscape. Additionally, he is now looking for transactions with other HHs. As soon as  $h$  encounters another HH (say  $\bar{h}$ ), who is also in mode 0, one of the two HHs is randomly determined to be the seller of a good and the other one to be the buyer. The price  $p$  is also randomly determined between 50% of the buyer's cash and zero.  $C^h$  is reduced by  $p$  while  $C^{\bar{h}}$  is increased by the same amount. As before, we assume (for ease of exposition) that the exchanged good does not enter the balance sheet.

This transaction causes one HH to enter mode 1 and the other to enter mode 2. The first will convert deposits into cash, while the second will transfer cash into deposits. As a result, BA  $b^{D,h}$  will end up with a shortage of liquidity and  $b^{D,\bar{h}}$  with a surplus. Of course, this (random) behavior is not particularly realistic. But since we are only interested in the impact of real sector transactions on the credit market, this way of modeling is sufficient for our purpose because it serves as a means for interbank lending.<sup>24</sup>

It is theoretically possible now that a BA  $b$  is not able to fulfill its debt obligations if, for example, some HHs demand liquidity from it over a short period of time and no other BA has a surplus of liquidity to grant a credit. Recall that  $b$  is never able to withdraw credits *immediately* to obtain liquidity. We, therefore, have to define how agents behave in such a case. For simplicity, we assume that, as soon as a BA  $b$  is not able to fulfill an obligation, it becomes public knowledge that it is insolvent. All HHs, who have deposits at it, immediately withdraw as much of them as possible (bank run) and no other BA will grant further credits to it. After a period of insolvency proceedings with randomly determined length up to 2000 time steps, the insolvent BA is removed. All remaining balance sheet positions are depreciated and those HHs for whom  $b^{D,h} = b$  holds will pick another solvent BA for placing their deposits.

Now that the interbank market is introduced, we will perform some simulations of the extended model.

## 5.6 Endogenous Instability

To analyze the impact of interbank lending on the credit market, we run a new simulation. Initially, all agents' balance sheet positions are again set to zero. We introduce money by an exogenous helicopter drop of 100 cash units that are equally distributed among HHs.

As in Section 5.4, we find that money is endogenously created over time (see Figure 5.7). But now, the economy does not smoothly approach an equilibrium and settle down there. Instead, when the market gets close to equilibrium (e.g.  $t = 20\,000, \dots, 32\,000$ ), we observe small unsystematic fluctuations (see zoom window) that emerge as a result of random trading. During such a period, one often finds a BA that is in mode 1 and simultaneously another BA in mode 2.<sup>25</sup> Consequently, there are a lot of interbank credits being granted during such times.

<sup>24</sup>Lenzu and Tedeschi (2011) use a similar mechanism and apply exogenous shocks that reduce the liquidity of one BA and at the same time increase that of another (p. 8).

<sup>25</sup>Recall, that this was impossible in the simulation of Section 5.4 because of the monotonic increase in  $M_1$ .

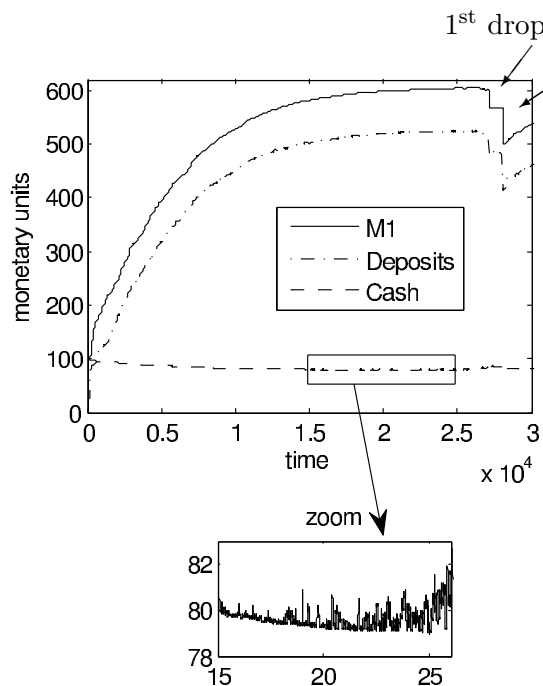

Figure 5.7: Development of monetary aggregates with interbank market

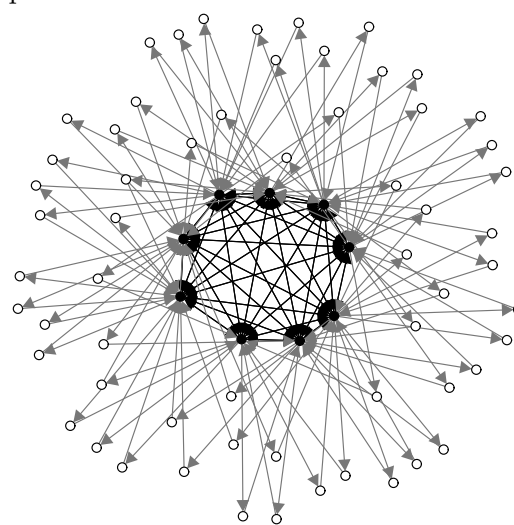

Figure 5.8: Network of claims with inter-bank market at  $t = 20\,000$

Now that BAs lend to each other, they are also directly linked by credit relations (illustrated as black lines in Figure 5.8). Interconnectedness of the network of claims will, thus, be higher.

Around  $t = 33\,000$  one BA becomes insolvent and has to leave the market. As a result, the deposits of some HHs and the interbank credits of some BAs are destroyed which lets the money amount drop. This destruction of money leads to a shortage of liquidity that drives another bank into insolvency shortly thereafter. Again, money is destroyed which is illustrated as a second drop in the monetary aggregates about 500 periods later.

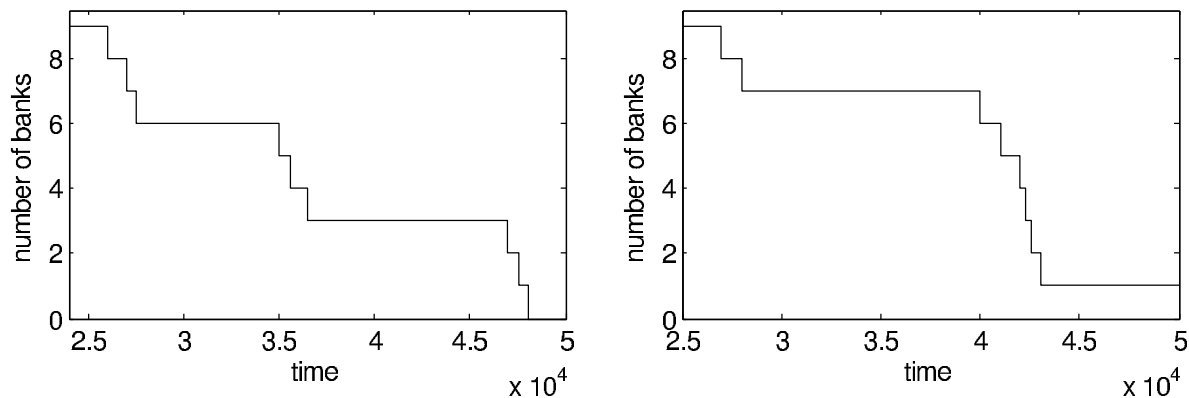

Figure 5.9: Example of the number of operating BAs over time if no BA survives (left) and if one BA survives (right).

Although, BA failures do occur now, convergence to the close neighborhood of the benchmark equilibrium (5.3) and (5.4) is still assured as long as, at least, one BA is present. Only if all BAs fail (no BA survives a bankruptcy cascade), endogenous money creation is not possible anymore. Two situations are possible as absorbing states of the system: (1) all BAs

have become bankrupt (Figure 5.9, left panel, at period  $\approx 4.8 \cdot 10^4$ ). In this case, higher monetary aggregates cannot be created and the benchmark equilibrium cannot be reached. (2) one BA survives the last bankruptcy chain (Figure 5.9, right panel, at period  $\approx 4.3 \cdot 10^4$ ). In this case, the benchmark equilibrium will still be reached. Such a state can never break down since a single BA cannot suffer large withdraws of liquidity in our model. Recall that liquidity withdraws are created by random transactions between two HHs that always result in one HH (the seller) with surplus liquidity and one (buyer) with a lack of liquidity. The former will increase its deposits, while the latter will withdraw cash. Since both are necessarily customers of the same BA (because there is only one left), their transactions will cancel out in the BA's balance sheet.

Running an MC experiment, we found that the model ends up in the first state with a probability of 73.7% and in the second with a probability of 26.3%. The impression might arise that the banking sector in our model is extremely fragile because of these high probabilities. Therefore we want to stress that the above probabilities are a natural result in our setting. If the probability of single BA failure in each period is small but positive and the entry of new BAs is not allowed, the number of BAs is necessarily decreasing over time until an absorbing state is reached. The probability of reaching either state 1 or 2 in the very long run therefore has to be 100%. Since these very long run absorbing states are of minor economic importance we neglect them in the remainder of this paper and focus on short-run stabilization.

### The Cause of Bankruptcies

To explain the chain of events that drives BAs into bankruptcy, we have to leave the macro level of aggregates and markets and enter the micro level of single agents and interactions. For illustration purpose, we pick one BA (say  $b$ ) at  $t = 20\,000$  and look at its balance sheet (Sheet 9). At this point in time,  $b$  has liquid funds equal to  $C^b + R^b = 3.01$ . As stated above, interbank credits have a fixed repay date. We can, therefore, create a liquidity forecast for  $b$  based on the current liquidity and its future change by due credits. Figure 5.10 shows such a forecast for the subsequent 2000 periods. For the current time step ( $k = 0$ ) it starts at 3.01. For  $k = 1, \dots, 2000$  it decreases if  $b$  has to repay credits and increases if  $b$  receives credit repayments from other BAs. Since interbank credits on the assets and liabilities side are almost equal ( $25.82 \approx 25.83$ ), the cash forecast ends up where it started (near 3).<sup>26</sup>

Bank  $b$  has a very robust financial position. Comparing with another bank (say  $\bar{b}$ ) at the same point in time, we find a very different picture. Sheet 10 and Figure 5.11 illustrate the situation of  $\bar{b}$ . The liquidity forecast starts at  $C^{\bar{b}} + R^{\bar{b}} = 2.17$ . It follows a downward trend because the bank has taken much more credits from other BAs than it has granted ( $35.26 > 28.15$ ). Around  $k = 600$ , the liquidity forecast falls below zero. In this situation,  $\bar{b}$  will not be able to fulfill its debt obligations. Note, however, that this insolvency is not a result of too low equity. The value of equity is zero from the beginning on since nothing is added or removed from it. It results simply because cash in- and outflows are asynchronous.

<sup>26</sup>Liquidity of 3.01 plus repayments *from* other BAs of 25.82 minus repayments *to* other BAs of 25.83 result in 3.00.

Sheet 9: Bank  $b$ ,  $t = 20\ 000$ 

| Assets  |        | Liabilities |        |
|---------|--------|-------------|--------|
| Cash    |        | HH Deposits |        |
|         | 0.01   |             | 75.01  |
| Reserve |        | BA Credits  |        |
|         | 3.00   |             | 25.83  |
| Credits |        | Equity      |        |
| HH      | 72.01  |             |        |
| BA      | 25.82  |             | 0.00   |
|         | 100.84 |             | 100.84 |

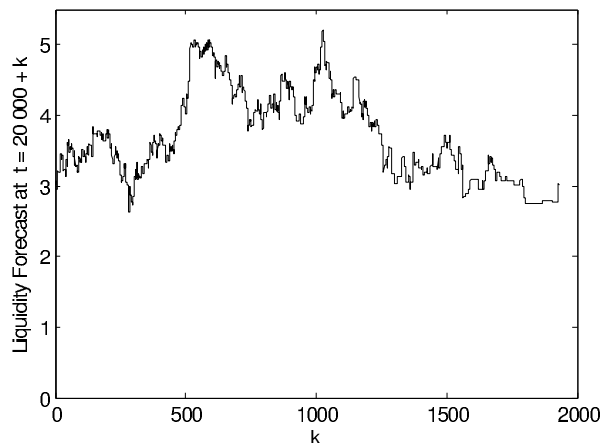
Figure 5.10: Liquidity forecast for  $b$ ,  $t = 20\ 000 \dots 22\ 000$ Sheet 10: Bank  $\bar{b}$ ,  $t = 20\ 000$ 

| Assets  |       | Liabilities |       |
|---------|-------|-------------|-------|
| Cash    |       | HH Deposits |       |
|         | 0.1   |             | 52.2  |
| Reserve |       | BA Credits  |       |
|         | 2.07  |             | 35.26 |
| Credits |       | Equity      |       |
| HH      | 57.14 |             |       |
| BA      | 28.15 |             | 0     |
|         | 87.46 |             | 87.46 |

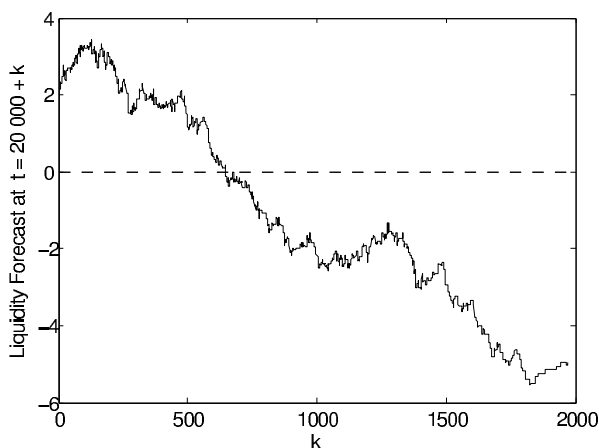
Figure 5.11: Liquidity forecast for  $\bar{b}$ ,  $t = 20\ 000 \dots 22\ 000$ 

Recall that the described situation is just a snapshot in  $t = 20\ 000$ . What will happen as time goes by? BA  $\bar{b}$  will repay credits and its liquid funds will decrease. Therefore, it will enter mode 2 and try to attain new liquidity (e.g. new credits from other BAs or withdraw loans from HHs). If  $\bar{b}$  is successful (e.g. in raising new credits) until  $t = 20\ 600$ , it does not become insolvent but, instead, rolls its debt position over. The process can continue and  $\bar{b}$  can stay in the market. At some future point in time ( $t = 33\ 000$ ), it might happen that, first, no other BA has the necessary surplus in liquidity and, second, the HHs, who borrowed from  $\bar{b}$ , are not able to repay as quick<sup>27</sup> as  $\bar{b}$  needs cash. Therefore,  $\bar{b}$  is unable to roll over the debt position and becomes insolvent. Other agents withdraw as much credits and deposits from  $\bar{b}$  as possible which makes the endogenously produced money amount fall (Figure 5.7). After the randomly determined length of the insolvency proceedings,  $\bar{b}$  is removed and all claims against it become worthless. Other BAs, which are also in a weak financial position or who have lent to  $\bar{b}$  and depend on repayment, will also be in trouble now and eventually become insolvent. A bankruptcy cascade might follow.

<sup>27</sup>Recall, that we have assumed in Section 5.3 that withdrawing credits from the real sector can not be done immediately but takes time.



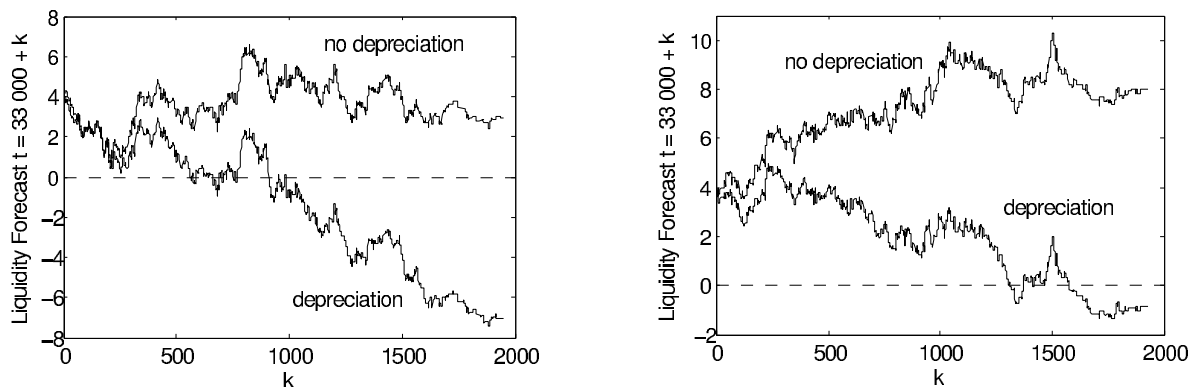

Figure 5.12: Liquidity forecasts of two lenders of  $\bar{b}$  with and without the depreciation of credits to  $\bar{b}$

We can illustrate the spillover of this cascade by looking at two lenders of  $\bar{b}$  (Figure 5.12). Both have a robust financial position: the liquidity forecast of the first one is almost a horizontal line, while that of the second has a slight upward trend (*no depreciation* case). If  $\bar{b}$  becomes insolvent, it is not able to pay all of its credits back. Consequently, the two lenders will not receive all of the granted credits back. The *depreciation* line shows the same liquidity forecasts but with all credits to  $\bar{b}$  depreciated, i.e. the development of liquid funds if no credit from  $\bar{b}$  is repaid. The insolvency of  $\bar{b}$  moves liquidity forecasts downward. Both BAs will, therefore, also be financially less robust. They withdraw credits and grant less to other BAs which can drive further BAs into insolvency and so on.

In our simulation, the crisis is spread by the non-performance of interbank debt. But the argument is general enough to be extended to any depreciation of bad debt. Regarding the current developments in southern Europe, for example, it is intuitively clear that a depreciation of bad government bonds has exactly the same effect on banks' liquidity position and can, therefore, also trigger a bankruptcy cascade among BAs.

We can identify instability as an *emerging property* of the aggregate that stems from asynchronous in- and outflows of liquidity created by individual transactions. The liquidity requirements of a failing BA, in turn, creates the risk of contagion. This result casts serious doubt on the value of general equilibrium modeling, since all interesting behavior is observed outside of equilibrium. For example, the question under what conditions a banking sector brakes down or what the government or CB can do to stop a bankruptcy cascade cannot be answered if we restrict ourselves to equilibrium.

To evaluate the threat of systemic risk, we perform a Monte Carlo experiment with 2000 runs of the model. Results are shown in table 5.1. The *start*-column gives the probability that, conditional on the amount of interbank credits in a period  $t$ , a first bank will fail in the near future (i.e. until  $t + 800$ ). The other columns give the conditional probability that, if a failure has been observed in  $t$ , a further bank will fail until  $t + 800$ . In other words, the *start*-column contains the probability that a crisis starts and the other columns those that it spreads to a further BA.

First of all, we find that the amount of interbank credits monotonically increases the probability to fail. This effect is obviously a result of a stronger entangled web of claims. If

a BA has taken more credits from others, it becomes more likely that these credits can not be payed back. Or, vice versa, the more credits a BA has granted, the more assets it has to depreciate if its borrowers fail. As a consequence, debt growth is a central factor that originates financial instability.<sup>28</sup>

Table 5.1: Conditional probabilities to become insolvent

| IB Credits | Recent BA failures |      |      |      |      |      |      |
|------------|--------------------|------|------|------|------|------|------|
|            | start              | 1    | 2    | 3    | 4    | 5    | > 5  |
| 0-200      | 0                  | 0.04 | 0    | 0    | 0    | 0    | 0    |
| 200-400    | 0.02               | 0.22 | 0.21 | 0.11 | 0.09 | 0.05 | 0.12 |
| 400-600    | 0.17               | 0.62 | 0.73 | 0.51 | 0.52 | 0.42 | 0.35 |
| 600-800    | 0.56               | 0.93 | 0.93 | 0.84 | 0.77 | 0.72 | 0.61 |
| > 800      | 0.88               | 0.99 | 0.99 | 0.94 | 0.84 | 0.77 | 0.75 |

We also find that the probability to observe a bankruptcy is much higher if there have been bankruptcies before. E.g. assume the system is in a state where interbank credits are between 400 and 600. In this state, the probability that an initial BA will fail is 0.17. But if one BA has already failed before, this probability increases to 0.62. If two BAs have failed before, it increases to 0.73. We can, therefore, identify a clear contagion effect of bankruptcies. This effect, however, *is non-monotonic*, i.e. probabilities are first increasing the more BAs have failed, but decreasing later on. In the case of IB credits > 800, it even falls below the probability that a crisis is started. The economic rationale for this non-monotonicity is the following: as soon as the first BAs are removed from the market, there are some HHs who have withdrawn as much deposits as possible from those BAs and consequently hold their wealth in cash only. Those households will pick another solvent BA for depositing part of their cash. Thus, they will provide further liquidity to the liquid BAs which will help to stabilize those. This behavior will bifurcate the economy. Money is withdrawn from the insolvent BAs and given to the solvent ones. The downside is that the latter will be in excess of liquidity but will not provide it to the former. The upside is, that such behavior protects the healthy BAs by reducing their probability to fail and, thus, helps to stop a cascade.<sup>29</sup>

Table 5.2: Conditional probabilities to become insolvent

| IB Market | Recent BA Breakdowns |      |      |      |      |      |     |
|-----------|----------------------|------|------|------|------|------|-----|
|           | start                | 1    | 2    | 3    | 4    | 5    | > 5 |
| Off       | 0.04                 | 0.14 | 0.23 | 0.22 | 0.09 | 0    | 0   |
| On        | 0.02                 | 0.78 | 0.9  | 0.8  | 0.72 | 0.59 | 0.4 |

We can now analyze the effect of an interbank market on the emergence of systemic risk. We perform another Monte Carlo simulation with the interbank market turned off, so that

<sup>28</sup>This point is also in line with Minsky's *Financial Instability Hypothesis*. Compare Minsky (1977), Minsky (1978) as well as Godley and Lavoie (2007) or Bezemer (2012a).

<sup>29</sup>A similar idea of bifurcation can be found in Leijonhufvud (2012).

the model equals the baseline version of the previous sections again. Table 5.2 compares the probabilities to fail, conditional on the existence of an interbank market. Firstly, we find that the probability of a first bank to fail is very small in both scenarios. The banking sector is, therefore, very stable under normal conditions. With no interbank market, the probability is only 0.04. If an interbank market exists, it even decreases to 0.02. The existence of an interbank market, therefore, stabilizes the banking sector because of the improved possibilities for BAs to refinance.

Secondly, we find that the probabilities of contagion are much higher if an interbank market exists (e.g.  $0.78 \gg 0.14$ ). The impact of an interbank market is, therefore, twofold. It stabilizes the banking sector under normal conditions but strongly increases systemic risk.<sup>30</sup> Interestingly, the probabilities of contagion do not become zero if the interbank market is turned off. Therefore, the interbank market amplifies but does not create systemic risk. If one BA becomes bankrupt, it starts withdrawing as much credits from HHs as possible. These HHs, in turn, withdraw deposits from other BAs. These other BAs might, thus, also be driven into liquidity problems and might ultimately become insolvent. Bankruptcy cascades can, thus, also be transmitted by HHs if BAs are not directly connected by an interbank market.

The probability of observing a total breakdown of the banking sector where all BAs fail in one single cascade is positive and results from multiplying all probabilities in one row. In the case of an interbank market this probability becomes  $0.02 \cdot 0.78 \cdot \dots \approx 0.00011$ , without an interbank market it becomes zero.

One strength of ACE modeling is that parameter heterogeneity can be directly introduced. We can, therefore, easily check whether our results are robust against assumption of parameter heterogeneity among agents. Instead of setting  $q = 0.15$  for all HHs, we draw the individual  $q^h$  from a uniform distribution with support  $[0.1, 0.2]$ , i.e.  $q^h \sim U(0.1, 0.2)$ . Since the reserve requirement is set by the CB, we do not assume heterogeneity among the parameter  $r$ . Repeating the Monte Carlo exercise shows that the above results are stable against parameter heterogeneity (results are not shown).

In another experiment, we analyze the role of large (systemically important) banks. We perform 500 independent simulations with different underlying random seeds. To calculate the impact of bank concentration on stability, we calculate (for each simulation  $i$ ) the number of BAs that survive 40000 ticks  $Y_i$  as a proxy of stability and different concentration measures  $X_i$  in the time step before the first BA becomes bankrupt. The size of each BA is proxied by its balance sheet size. In five regressions of the form

$$Y_i = \beta_0 + \beta_1 \cdot X_i, \quad (5.5)$$

our stability proxy  $Y_i$  is regressed on one concentration measure  $X_i$ . Since regression results are going to depend on the way concentration is measured, we directly check the robustness of our estimation by using five different measures: size of the largest BA, standard deviation

---

<sup>30</sup>This result is in line with Farmer et al. (2012), p. 14: “[...] *interbank lending [...] can provide security in normal times but may amplify the extend of a crash in bad times.*”

of BA size, Herfindahl index, Theil's index and Gini coefficient. Estimation results for  $\beta_1$  and the corresponding  $p$ -values are shown in table 5.3. All estimates suggest that the influence of concentration (i.e. the existence of large BAs) on stability is *negative*. This effect is robust over all applied concentration measures. Since  $X_i$  is located on a very different interval depending on the underlying index, we are not able to compare the different estimates of  $\beta_1$  directly. To be able to compare the estimates quantitatively, we calculate the percentage change in stability  $\frac{\Delta Y}{Y}$  that is induced by a one percent change in the stability measure  $X$  in an economy with average concentration  $\bar{X} = \frac{1}{500} \sum_i X_i$  (last row of table 5.3). Our calculations show that a 1% increase in concentration is roughly followed by a stability decrease between 0.11% and 0.99%.

Table 5.3: The effect of concentration on stability

| $X_i$  | Largest      | Std          | HHI          | Theil        | Gini         |
|--|--------------|--------------|--------------|--------------|--------------|
| $\hat{\beta}_1$                                    | -0.016       | -0.039       | -26.9        | -0.5         | -3.9         |
| $p$ -value   | <i>0.000</i> | <i>0.000</i> | <i>0.012</i> | <i>0.004</i> | <i>0.014</i> |
| $\frac{\Delta Y}{Y}$ if $\frac{\Delta X}{X} = 1\%$ | -0.88%       | -0.51%       | -0.99%       | -0.11%       | -0.22%       |

To check the robustness of our findings against different measures of stability, we perform an estimation of a binary choice probit. As explaining variable, we use the same five concentration measures as before while the endogenous (binary) event  $Y_i = 1$  is now given by the occurrence of a total breakdown of our economy.<sup>31</sup> All qualitative results still hold under the changed specifications: estimators and marginal effects are positive (table 5.4). Since it is again difficult to compare the obtained marginal effects in a quantitative way, we calculate the implied change in probability for a total breakdown to occur given a 1% change in concentration. Our results (last row of table 5.4) show that an increase in BA concentration by 1% is followed by an increase in the probability of a total breakdown between 0.06% and 0.61%.

Table 5.4: The effect of concentration on total breakdowns

| $X_i$  | Largest      | Std          | HHI          | Theil        | Gini         |
|--|--------------|--------------|--------------|--------------|--------------|
| $\hat{\beta}_1$                                    | 0.0078       | 0.0199       | 16.92        | 0.294        | 2.38         |
| $p$ -value   | <i>0.000</i> | <i>0.000</i> | <i>0.014</i> | <i>0.007</i> | <i>0.021</i> |
| marginal effects                                   | 0.0022       | 0.0056       | 4.87         | 0.084        | 0.686        |
| $\Delta Prob(Y = 1)$ if $\frac{\Delta X}{X} = 1\%$ | 0.41%        | 0.25%        | 0.61%        | 0.06%        | 0.13%        |

From this section, we can robustly conclude that a financial sector composed of equally sized BAs is more stable than one composed of BAs with strongly differing size. In Section 5.7, we come back to this result and show that regulatory policy should regulate large BAs over-proportionately strong to counteract on the instability they create.

<sup>31</sup>We define a total breakdown as a situation in which only one or less BAs survive because in such a situation no further bank failures are possible.

### An Aggregate Perspective

The strength of ACE modeling is that it allows for a completely disaggregated view on the economy. This advantage can be pointed out by asking ourselves how the previous simulations of this section would have looked like if one does not have access to individual information in the simulation but only to aggregates. For example, if we would only have the sum of all individual HHs as *the household sector* that is “representing” all its constituting individuals and only the sum of all BAs as *the banking sector*.

Sheet 11: Household sector

| Assets   | Liabilities |
|----------|-------------|
| Cash     | Loan Bank   |
| 79.99    | 492.65      |
| Deposits |             |
| 512.66   |             |
|          | Equity      |
|          | 100         |
| 592.65   | 592.65      |

Sheet 12: Banking sector

| Assets    | Liabilities |
|-----------|-------------|
| Cash      | HH Deposits |
| 0.00      | 512.66      |
| Reserve   | BA Credits  |
| 20.01     | 0           |
| Credits   |             |
| HH 492.65 | Equity      |
| BA 0      | 0           |
| 512.66    | 512.66      |

Sheets 11, 12 and 13 show the situation of the above simulation at  $t = 20\,000$  from an accounting perspective. First of all, the three balance sheets look qualitatively identical to the ones before. But there is an important difference in the balance sheet of the banking sector. Since every interbank credit appears on the assets side of one bank and the liabilities’ side of another, it cancels out in the aggregate ( $I_+ = I_- = 0$ ). Interbank lending, therefore, simply disappears on the aggregate level (Sheet 12). This becomes evident by looking at the cash forecast of the banking sector (Figure 5.13). Since all committed repayments of interbank loans induce a positive flow for one bank and a negative flow for another, they also cancel out on the aggregate and the cash forecast becomes a horizontal line. Since this horizontal line can impossibly intersect with the horizontal-axis, we are not able to see the event of insolvency as a result of maturity mismatch. At the same time, we are unable to picture the credit market as an endogenous network but only as the relation between two aggregate representatives in isolation (Figure 5.14). An event, like agent  $A$  withdrawing credits from  $B$  which forces  $B$  to withdraw from  $C$  and so on (i.e. a bankruptcy cascade through the web transmitted by the individual need for liquidity), is simply impossible when dealing with aggregates.

Sheet 13: Central bank

| Assets | Liabilities |
|--------|-------------|
| Gold   | Currency    |
| 150    | 79.99       |
|        | BA Deposits |
|        | 20.01       |
|        | Equity      |
|        | 50          |
| 150    | 150         |

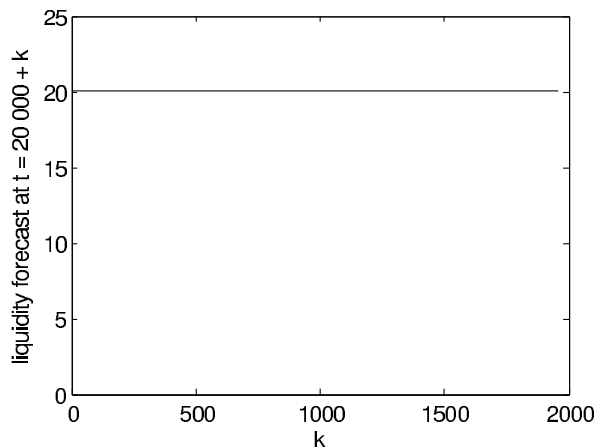

Figure 5.13: Liquidity forecast for banking sector,  $t = 20\,000 \dots 22\,000$



Figure 5.14: Network of claims on aggregate level,  $t = 20\,000$

These considerations make clear why it is problematic to deal with aggregates directly, even if they are sums of heterogeneous individuals or SFC. Financial instability is neither deducible from the behavior of a single individual in isolation nor from the aggregate of all (maybe heterogeneous) individuals. These considerations illustrate why it is *not* sufficient to replace the rational representative agent by a non-rational one,<sup>32</sup> or to introduce heterogeneity among some kinds of agents, sum them up and confront the resulting sums of supply and demand with the other side of the market. How maturity mismatches create systemic financial risk can only be understood in an individual and interaction based analysis with a consistent accounting structure.

## 5.7 Standing Facilities, Reserve Requirements and Regulatory Policy

In this section, we extend our framework by allowing BAs to receive liquidity from the CB via standing facilities. We assume that BAs can, by its own initiative, place a secure asset (e.g. AAA bonds) at the CB to obtain liquidity. Technically, the CB and each BA are given a new position on its assets' side  $S$  (compare Sheets 14 and 15) that denotes the amount of such assets they possess. If a BA makes use of standing facilities, we add a positive value to its account at the CB  $R^b$ , subtract the same value from its bonds  $S^b$ , add it to the CB's bonds  $S^{cb}$  and create a liability for the CB against the BA by increasing  $R^{cb}$ .

For simplicity, we control the initial endowment of save assets exogenously. Since all balance sheet entries are initially zero, the equity position of banks becomes equal to their initial endowment of assets. Additionally, we assume that each BA is now *forced* by the CB

<sup>32</sup>As done, for example, in the literature on learning. Compare Evans and Honkapohja (2001) or Adam (2005) among others.

Sheet 14: BA  $b$  with secure assets

| Assets    |         | Liabilities           |
|-----------|---------|-----------------------|
| Cash      | $C^b$   | HH Deposits<br>$D^b$  |
| Reserve   | $R^b$   | BA Credits<br>$I_-^b$ |
| Credits   |         |                       |
| HH        | $L^b$   |                       |
| BA        | $I_+^b$ |                       |
| AAA Bonds | $S^b$   | Equity<br>$E^b$       |

Sheet 15: CB with secure assets

| Assets                | Liabilities             |
|-----------------------|-------------------------|
| AAA Bonds<br>$S^{cb}$ | Currency<br>$C^{cb}$    |
|                       | BA Deposits<br>$R^{cb}$ |
|                       | Equity<br>$E^{cb}$      |

to hold  $R^b$  at the amount given by (5.2). Similar to all other non-fulfilled obligations, we declare a BA bankrupt as soon as it fails to provide the required reserves.<sup>33</sup>

### Microprudential Bank Regulation

The Bank of International Settlements has published new regulatory rules for commercial banks in December 2010 (known as Basel III) with the aim of increasing the stability of the financial sector. Among others, the new guide lines strengthen the capital requirements as they increase the core capital quota (CCQ), which is defined as the minimum ratio of core equity capital that a bank has to hold in relation to its risk weighted assets, from 2% to 7%.<sup>34</sup> In this subsection, we use our model to analyze the implications of Basel III CCQ requirements on aggregate stability. For simplicity, we assume  $L^b$  to be the part of BA assets that the regulator has defined to be risky. The CCQ is, thus, given by:

$$CCQ_b = \frac{E^b}{L^b} \quad (5.6)$$

To determine the impact different CCQ regulatory settings have on stability, we perform the following experiment:<sup>35</sup>

1. Perform one simulation for a given endowment of secure assets  $S^1, S^2, \dots, S^B$  with random trading turned off to obtain a steady state benchmark.
2. Perform the same simulation with random trading turned on for 1000 different realizations of the random number generator.
3. Repeat step 1 and 2 for different endowments with save assets.

<sup>33</sup>In previous examples BAs were able to buffer shortages of liquidity by bringing down reserves at the CB without ever being punished. Introducing standing facilities, would strongly increase stability, because BAs are just given an additional liquidity buffer (reserve requirements + AAA bonds). E.g. increasing AAA bonds from 0 to 8 would result in an increase in stability  $Y_i$  (compare p. 73) from 3.6 to 4.8. By assuming that reserve requirements are mandatory, we replace the previously used reserves-buffer by a AAA-bonds-buffer.

<sup>34</sup>We neglect here that there is also a cyclical component in the CCQ requirement that allow banks to fall below 7% for some time to buffer the credit contraction that appears typically during recessions.

<sup>35</sup>Computationally, these steps are already (despite the model's simplicity) very involved. We have run the simulations from this section in parallel on a high-performance Linux-Cluster. Running them on a standard desktop computer would have taken about one week.

The endowment with save assets is controlled in two ways. First, we vary the sum  $S^{Aggr} = \sum_b S^b$  of all BAs to control for the impact of larger capital requirements in general. Second, we control for the initial distribution of  $S^b$  among BAs according to their size. A similar aspect can be found in Basel III where higher CCQs are set for banks that are declared as *systemically relevant*.<sup>36</sup> Let save assets of  $b$  be given by

$$S_b = S^{Aggr} \frac{size_b^\alpha}{\sum_{i=1}^B size_i^\alpha} \quad (5.7)$$

where the size of a BA ( $size_b$ ) is now given by the amount of loans to HHs (obtained from the benchmark simulation). By defining  $size_b$  this way, the baseline case ( $\alpha = 1$ ) results in a distribution of assets that is proportional to BA's loans and, hence, CCQs that are equal among banks. In case  $\alpha = 0$ , the absolute endowment of  $S^b$  is equal among banks. In this case, small BAs face larger CCQs than large ones. The opposite holds for  $\alpha > 1$ , where CCQs will be larger for big BAs.

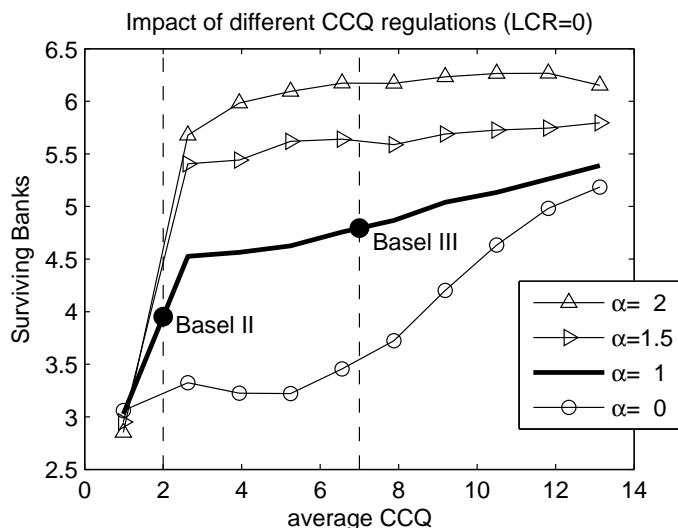

Figure 5.15: Impact of different CCQ regulations on stability

To illustrate the influence of banks' capital basis on systemic risk, we plot the average steady state CCQ obtained from step 1 against the average relative number of BAs that survive the first 40000 periods in step 2 (Figure 5.15). The results are in line with Hannoun (2010), Allen et al. (2012) and also Arnold et al. (2012) who state that banks' capital basis were too low in the pre-crisis period, i.e. we show that a larger capital basis (larger CCQ) has a positive effect on stability. The intention of Basel III to increase stability by forcing banks to increase their CCQ from 2% to 7% is, thus, confirmed.

Additionally, we find that a higher value of  $\alpha$  results in a more stable banking sector. Comparing, for example, the Basel III setting of 7% CCQ for different values of  $\alpha$  shows that higher values of  $\alpha$  result in a more stable financial sector, e.g. stability increases from 35 to 56 if  $\alpha$  is increased from 0 to 2. Regulating large banks more strictly than small ones (as Basel

<sup>36</sup>Compare BCBS (2011).



III already does, see BCBS (2011)) has a positive effect on stability, although the average CCQ has not changed.

## 5.8 Conclusion

We present an ACE model of the credit and interbank market. The only two different kinds of agents it consists of are household/firms and banks, both of which follow very simple behavioral rules. We show how money is produced in the banking sector (as a multiple of the monetary base) through individual interactions in a disequilibrium process. Our model is a generalization of standard theory since it contains the common equilibrium result as a limiting case.

We also show that the creation of money inevitably produces instability. When applying a perspective that is strictly individual based and SFC, it is impossible to make sense of endogenous money without a web of claims between agents. This web, however, produces the threat of systemic risk. Instability is, therefore, systematically produced in monetary economies and can not be put aside as an *exogenous shock* or a *friction*.

Additionally, we show that the banking sector is more stable if it is composed of equally sized banks. The existence of large banks creates endogenous instability. As a consequence, regulatory policy should be more restrictive for such large banks compared to small ones.

The model can also be used to answer further policy relevant questions. For instance, the capital and liquidity requirements proposed by the Basel Committee on Banking Supervision aims to mitigate the subsequent destabilizing effects of a spreading/growing credit network on the economy since they have been identified as key drivers of financial instability. Hence, it would be worthwhile to analyze in what way the implementation of the complete spectrum of the Basel III regulatory framework (apart from just CCQ) would affect the outcome of the model in terms of bank defaults. Furthermore, the effects of single and simultaneous requirements as well as the impact of pure micro- or macroprudential instruments could be compared.

## 5.9 References

- Ackerman, F. (2002). Still Dead After All These Years: Interpreting the Failure of General Equilibrium Theory, *Journal of Economic Methodology* **9**(2): p. 119–139.
- Adam, K. (2005). Learning to Forecast and Cyclical Behavior of Output and Inflation, *Macroeconomic Dynamics* **9**: 1–27.
- Allen, B., Chan, K. K., Milne, A. and Thomas, S. (2012). Basel III: Is the cure worse than the disease?, *International Review of Financial Analysis* **25**: 159–166.
- Arnold, B., Borio, C., Ellis, L. and Moshirian, F. (2012). Systemic Risk, Macroprudential Policy Frameworks, Monitoring Financial Systems and the Evolution of Capital Adequacy, *Journal of Banking & Finance* **36**: 3125–3132.

- Arnold, P. J. (2009). Global Financial Crisis: The Challenge to Accounting Research, *Accounting, Organizations and Society* **34**: 803–809.
- Axtell, R. L. (2007). What Economic Agents do: How Cognition and Interaction Lead to Emergence and Complexity, *The Review of Austrian Economics* **20**: 105–122.
- Bank of England (2011). Instruments of Macroprudential Policy, *BoE Discussion Paper, December*.
- Battiston, S., Delli Gatti, D., Gallegati, M., Greenwald, B. and Stiglitz, J. E. (2012). Liasons Dangereuses: Increasing Connectivity, Risk Sharing, and Systematic Risk, *Journal of Economic Dynamics and Control* **36**(8): 1121–1141.
- BCBS (2011). (Basel Committee on Banking Supervision), Global systemically important banks: assessment methodology and the additional loss absorbency requirement, *Rules text of the Bank of International Settlements, Basel*.
- Bezemer, D. J. (2010). Understanding Financial Crisis Through Accounting Models, *Accounting, Organizations and Society* **35**: 676–688.
- Bezemer, D. J. (2012a). Finance and Growth: When Credit Helps, and When it Hinders, *Paper presented at the INET Conference "Rethinking Economics and Politics" in Berlin*.
- Bezemer, D. J. (2012b). The Economy as a Complex System: The Balance Sheet Dimension, *Advances in Complex Systems* **15**.
- Caverzasi, E. and Godin, A. (2013). Stock-flow Consistent Modeling through the Ages, *WP 245 of Levy Economics Institute*.
- Chen, S.-H. (2012). Varieties of Agents in Agent-Based Computational Economics: A Historical and an Interdisciplinary Perspective, *Journal of Economic Dynamics and Control* **36**: 1–25.
- Cincotti, S., Raberto, M. and Teglio, A. (2010). Credit Money and Macroeconomic Instability in the Agent-based Model and Simulator Eurace, *Economics: The Open-Access, Open-Assessment E-Journal* **4**(2010-26).
- Cocco, J., Gomes, F. and Martins, N. (2009). Lending Relationships in the Interbank Market, *Journal of Financial Intermediation* **18**: 24–48.
- Colander, D., Howitt, P., Kirman, A., Leijonhufvud, A. and Mehrling, P. (2008). Beyond DSGE Models: Toward an Empirically Based Macroeconomics, *American Economic Review* **98**: p. 236–240.
- Delli Gatti, D., Gaffeo, E. and Gallegati, M. (2010). Complex Agent-Based Macroeconomics: A Manifesto for a New Paradigm, *Journal of Economic Interaction and Coordination* **5**(2): p. 111–135.
- Demiralp, S., Preslowsky, B. and Whitesell, W. (2006). Overnight Interbank Loan Markets, *Journal of Economics and Business* **58**: 67–83.
- Evans, G. and Honkapohja, S. (2001). *Learning and Expectations in Macroeconomics*, Princeton University Press.

- Fagiolo, G. and Roventini, A. (2012). Macroeconomic Policy in DSGE and Agent-Based Models, *Revue de l'OFCE, Presses de Sciences-Po* **5**(124): 67–116.
- Fair, R. C. (2009). Has Macro Progressed?, *Cowles Foundation Discussion Papers* **1728**.
- Farmer, J. D., Gallegati, M., Hommes, C., Kirman, A., Ormerod, P., Cincotti, S., Sanchez, A. and Helbing, D. (2012). A Complex Systems Approach to Constructing better Models for Managing Financial Markets and the Economy, *European Physics Journal Special Topics* **214**: 295–324.
- Financial Accounting Standards Board (1985). Statement of Financial Accounting Concepts No. 6, *Technical report*.
- Gaffeo, E., Delli Gatti, D., Desiderio, S. and Gallegati, M. (2008). Adaptive Microfoundations for Emergent Macroeconomics, *Eastern Economic Journal* **34**: 441–463.
- Gode, D. K. and Sunder, A. (2004). Double Auction Dynamics: Structural Effects of Non-Binding Price Controls, *Journal of Economic Dynamics and Control* **28**: 1707–1731.
- Godley, W. and Cripps, F. (1983). *Macroeconomics*, Oxford University Press.
- Godley, W. and Lavoie, M. (2007). Fiscal Policy in a Stock-Flow Consistent (SFC) Model, *Journal of Post Keynesian Economics* **30**(1): 79–100.
- Grimm, V., Berger, U., DeAngelis, D. L., Polhill, J. G., Giske, J. and Railsback, S. F. (2010). The ODD protocol: A review and first update, *Ecological Modelling* pp. 2760–2768.
- Hannoun, H. (2010). Towards a Global Financial Stability Framework, *45th SEACEN Governors' Conference* .
- Harris, M. and Raviv, A. (1990). Capital Structure and the Informational Role of Debt, *Journal of Finance* **45**(2): 321–349.
- Jensen, M. C. (1986). Agency Costs of Free Cash Flow, Corporate Finance, and Takeovers, *The American Economic Review* **76**(2): 323–329.
- Keen, S. (2009). Mad, Bad, and Dangerous to Know, *Real-World Economics Review* **49**: p. 2–7.
- Kirman, A. (2010). The Economic Crisis is a Crisis for Economic Theory, *CESifo Economic Studies* **56**: 498–535.
- Krause, A. and Giansante, S. (2012). Interbank Lending and the Spread of Bank Failures: A Network Model of Systemic Risk, *Journal of Economic Behavior & Organization* **83**(3): 583–608.
- Lavoie, M. and Zezza, G. (eds) (2012). *The Stock-Flow Consistent Approach: Selected Writings of Wynne Godley*, Palgrave Macmillan.
- Leijonhufvud, A. (2012). The Unstable Web of Contracts, *Presentation held at the INET Conference "Rethinking Economics and Politics" in Berlin* .
- Lenzu, S. and Tedeschi, G. (2011). Systematic Risk on Different Interbank Network Topologies, *Working Paper* .

- Mallet, J. (2012). What are the Limits on Commercial Bank Lending, *Advances in Complex Systems* **15**.
- Milne, A. (2013). Register, Cap and Trade: A Proposal for Containing Systemic Liquidity Risk, *Economics: The Open-Access, Open-Assessment E-Journal* **7**.
- Minsky, H. P. (1977). The Financial Instability Hypothesis: An Interpretation of Keynes and an Alternative to Standard Theory, *Nebraska Journal of Economics and Business* **16**(1): 5–16.
- Minsky, H. P. (1978). The Financial Instability Hypothesis: A Restatement, *Hyman P. Minsky Archive Paper 180*.
- Obstfeld, M. and Rogoff, K. (1996). *Foundations of International Macroeconomics*, MIT Press.
- Patterson, K. D. and Stephenson, M. J. (1988). Stock-Flow Consistent Accounting: A Macroeconomic Perspective, *The Economic Journal* **98**: 787–800.
- Russo, A., Catalano, M., Gaffeo, E., Gallegati, M. and Napoletano, M. (2007). Industrial Dynamics, Fiscal Policy and R&D: Evidence from a Computational Experiment, *Journal of Economic Behavior & Organization* **64**: 426–447.
- Stulz, R. (1990). Managerial Discretion and Optimal Financing Policies, *Journal of Financial Economics* **26**: 3–27.
- Taylor, L. (2008). A Foxy Hedgehog: Wynne Godley and Macroeconomic Modelling, *Cambridge Journal of Economics* **32**(4): 639–663.
- Tedeschi, G., Mazloumian, A., Gallegati, M. and Helbing, D. (2011). Bankruptcy Cascades in Interbank Markets, *Working Paper*.
- Teglio, A., Raberto, M. and Cincotti, S. (2012). The Impact Of Banks' Capital Adequacy Regulation On The Economic System: An Agent-Based Approach, *Advances in Complex Systems* **15**.
- Ussher, L. J. (2008). A Speculative Futures Market with Zero-Intelligence, *Eastern Economic Journal* **34**: 518–549.

## Chapter 6

# The Impact of Basel III on Financial (In)stability: An Agent-based Credit Network Approach

*Published in:* Quantitative Finance (2015), *forthcoming*.

*Coauthored by:* Sebastian Krug, Hans-Werner Wohltmann

### Abstract

The Basel III accord reacts to the events of the recent financial crisis with a combination of revised micro- and new macroprudential regulatory instruments to address various dimensions of systemic risk. This approach of cumulating requirements bears the risk of individual measures negating or even conflicting with each other which might lessen their desired effects on financial stability. We provide an analysis of the impact of Basel III's main components on financial stability in a stock-flow consistent (SFC) agent-based computational economic (ACE) model. We find that the positive joint impact of the microprudential instruments is considerably larger than the sum of the individual contributions to stability, i.e. the standalone impacts are non-additive. However, except for the buffers, the macroprudential overlay's impact is either marginal or even destabilizing. Despite its simplicity, the leverage ratio performs poorly especially when associated drawbacks are explicitly taken into account. Surcharges on SIBs seem to rather contribute to financial regulations complexity than to the resilience of the system.

*Keywords:* Banking Supervision, Basel III, Liquidity Coverage Ratio, Macroprudential Regulation, Financial Instability, Agent-based Computational Economics

*JEL classification:* G01, G28, E40, C63

The full article can be downloaded via  
<http://dx.doi.org/10.1080/14697688.2014.999701>

DOI: 10.1080/14697688.2014.999701

## Chapter 7

# Outlook and Future Research

In chapter 2 and 3 we develop a model describing the interactions between financial markets and the real economy. The model was used to answer several policy-relevant questions. With respect to internal validation, the presented model is superior to its competitors since its interactive channels are microfounded and not assumed ad hoc. Future research, however, has to clarify which of the proposed channels are empirically most relevant to also provide external validation.

While a detailed analysis of optimal policy rules under commitment has been performed, the treatment of optimal unrestricted policies and monetary policy under discretion had to be postponed. Future research should clarify to what extent the well-known results of optimal monetary policy hold, if rational expectations are relaxed in advance of bounded rationality.

We have demonstrated that the model is not only capable of analyzing the standard questions of monetary policy (e.g. derive optimal simple rules). It can also be used to answer several questions that are currently on the political agenda: First, we have derived optimal taxation of financial transactions. Second, we have shown that even results concerning optimal *unconventional* policy can be derived straight forwardly. Given the current developments of monetary policy in Europe, the latter is of major importance for practical considerations. Future research should further investigate the potential strengths and drawbacks of applying unconventional monetary instruments.

The model, developed in chapter 4 contributes to macroeconomic theory, because it allows for a modeling methodology that corrects most of the criticism that has been drawn against the DSGE paradigm. At the same time it is much simpler than other macroeconomic models of the ACE type.

The major drawback of the presented model is, that empirical remarks have only been used to validate the ACE model. The confrontation with DSGE has been done on a theoretical level only. Although this confrontation is important, since most of the currently expressed criticism is concerned with theoretical problems, future research has to compare ACE and DSGE in quantitative terms also (e.g. forecasting accuracy).

For a better acceptance of the ACE method in macroeconomics, two further steps have to be taken in future research: First, it has to be shown that all the standard question (e.g.

optimal monetary policy, size of fiscal multipliers, etc.) can be answered satisfactorily in ACE models. Second, the model complexity has to be reduced even further. Current ACE modeling in macroeconomics is relatively complicated (theoretically, but also technically). Building such models, therefore, implies high costs to economists of typical educational background. The practical implementation of ACE macroeconomic models has to become simpler if a paradigm shift is aspired.

The model presented in chapter 5 can be seen as a further step in this direction. The model mimics closely the text-book approach to money creation (low theoretical burden). At the same time it is written in a programming framework which is easy to learn, NetLogo, and can be accessed by students easily like a computer game (low practical burden). In chapter 6 we demonstrate that, although simple, the model can be used to answer important, currently discussed policy questions. It is thus worth exploring further.



# Curriculum Vitae

Last Name: Lengnick  
First Name: Matthias  
Address: Wilhelm-Seelig-Platz 1, R. 307  
24118 Kiel, Germany  
E-Mail: lengnick@economics.uni-kiel.de

## EDUCATION

---

10/2009          Diploma in Economics ('Diplom-Volkswirt'), University of Kiel  
since 02/2010   Participant in the PhD-Programme 'Quantitative Economics', University of Kiel

## PUBLICATIONS

---

Krug, Sebastian & Lengnick, Matthias & Wohltmann, Hans-Werner, 2015 (forthcoming). *"The impact of Basel III on financial (in)stability: An agent-based credit network approach"*, Quantitative Finance.

Lengnick, Matthias & Krug, Sebastian & Wohltmann, Hans-Werner, 2013. *"Money creation and financial instability: An agent-based credit network approach"*, Economics – The Open-Access, Open-Assessment E-Journal, Kiel Institute for the World Economy, vol. 7, pages 1-44.

Matthias Lengnick & Hans-Werner Wohltmann, 2013. *"Agent-based financial markets and New Keynesian macroeconomics: A synthesis"*, Journal of Economic Interaction and Coordination, Springer, vol. 8(1), pages 1-32, April.

Lengnick, Matthias, 2013. *"Agent-based macroeconomics: A baseline model"*, Journal of Economic Behavior & Organization, Elsevier, vol. 86(C), pages 102-120.

## WORKING PAPERS

---

Krug, Sebastian & Lengnick, Matthias & Wohltmann, Hans-Werner, 2014. *"The impact of Basel III on financial (in)stability: An agent-based credit network approach"*, Economics Working Papers 2014-13, Christian-Albrechts-University of Kiel, Department of Economics.

Lengnick, Matthias & Wohltmann, Hans-Werner, 2014. *"Optimal monetary policy in a new Keynesian model with animal spirits and financial markets"*, Economics Working Papers 2014-12, Christian-Albrechts-University of Kiel, Department of Economics.

Lengnick, Matthias & Krug, Sebastian & Wohltmann, Hans-Werner, 2012. *"Money creation and financial instability: An agent-based credit network approach"*, Economics Working Papers 2012-15, Christian-Albrechts-University of Kiel, Department of Economics.

Lengnick, Matthias, 2011. *"Agent-based macroeconomics - a baseline model"*, Economics Working Papers 2011-04, Christian-Albrechts-University of Kiel, Department of Economics.

Lengnick, Matthias & Wohltmann, Hans-Werner, 2010. *"Agent-based financial markets and New Keynesian macroeconomics: A synthesis"*, Economics Working Papers 2010-10, Christian-Albrechts-University of Kiel, Department of Economics.

# Eidesstattliche Erklärung

Hiermit erkläre ich an Eides statt, dass ich meine Doktorarbeit "*Essays in Agent-Based Macro and Monetary Economics*" selbstständig und ohne fremde Hilfe angefertigt habe und dass ich alle von anderen Autoren wörtlich übernommenen Stellen, wie auch die sich an die Gedanken anderer Autoren eng anlehenden Ausführungen meiner Arbeit, besonders gekennzeichnet und die Quellen nach den mir angegebenen Richtlinien zitiert habe.

\_\_\_\_\_ Datum

\_\_\_\_\_ Unterschrift