

**Abiotic and biotic impacts on fish in the Wadden Sea.
Evaluating the effect of large scale climate
oscillations, local ecosystem characteristics and
invasive species**



Source and copyright front cover:

Island of Sylt and NAO data: <http://www.noaa.gov/>; <http://commons.wikimedia.org/wiki/File:SyltSat.jpg>

Pomatoschistus microps: Florian Kellnreitner, Moritz Pockberger

Caprella mutica, *Sargassum muticum*: Christian Buschbaum

**Abiotic and biotic impacts on fish in the Wadden Sea. Evaluating the effect of large scale
climate oscillations, local ecosystem characteristics and invasive species**

Dissertation

zur Erlangung des Doktorgrades

der Mathematisch-Naturwissenschaftlichen Fakultät

der Christian-Albrechts-Universität zu Kiel

vorgelegt von

Moritz Pockberger

Kiel, 2015

Prüfungskommission:

PD Dr. Harald Asmus (Erster Gutachter)

Alfred-Wegener-Institut, Helmholtz-Zentrum für Polar und Meeresforschung, List

Prof. Dr. Oscar Puebla (Zweiter Gutachter)

GEOMAR, Helmholtz-Zentrum für Ozeanforschung, Kiel

Prof. Dr. Martin Wahl (Vorsitzender)

GEOMAR, Helmholtz-Zentrum für Ozeanforschung, Kiel

Univ. Doz. Dr. Harald Ahnelt

Universität Wien, Department für Theoretische Biologie, Wien

Prof. Dr. Maarten Boersma

Alfred-Wegener-Institut, Helmholtz-Zentrum für Polar und Meeresforschung, List

Tag der mündlichen Prüfung: 12.05.2015

Zum Druck genehmigt: 12.05.2015

gez. Prof. Dr. Wolfgang J. Duschl, Dekan

By the time it comes to interpretations of the substantive conclusions, the assumptions on which the model has been based are easily forgotten. But it is precisely the empirical validity of these assumptions on which the usefulness of the entire exercise depends.

Wassily Wassilyovich Leontief

TABLE OF CONTENTS

SUMMARY	I
ZUSAMMENFASSUNG	V
GENERAL INTRODUCTION	1
1.1. Ecosystems of the Wadden Sea	3
1.2. Climate in the Wadden Sea area	6
1.3. Invasive and bioengineer species	8
1.4. Invasive species in the Wadden Sea	9
1.5. Ecological Network Analyses	13
1.5.1. Historical background and development	13
1.5.2. Benefits, basic principles and requirements to conduct ENA	14
1.5.3. Evaluation of ecosystem properties	16
1.5.4. The concept and identification of keystone species	18
1.6. Fish important components and indicators in ecosystems	19
THESIS OUTLINE	33
CHAPTER I. THE FISH COMMUNITY IN THE NORTHERN WADDEN SEA RELATED TO ABIOTIC FACTORS AND LARGE SCALE CLIMATE OSCILLATIONS	41
CHAPTER II. AN ABUNDANT SMALL SIZED FISH AS KEYSTONE SPECIES? THE EFFECT OF <i>POMATOSCHITUS MICROPS</i> ON FOOD WEBS AND ITS TROPHIC ROLE IN TWO INTERTIDAL BENTHIC COMMUNITIES: A MODELING APPROACH	85
CHAPTER III. INVESTIGATION OF FISH SPECIES OCCURRENCE AND COMPOSITION INTRODUCED ALGAL FORESTS (<i>SARGASSUM MUTICUM</i>): PROVIDING A NEW HABITAT FOR NATIVE FISH?	121
CHAPTER IV. INTERNAL PROCESSES OF A HABITAT FORMING SPECIES: WHAT IS HIDDEN BEHIND DENSE FORESTS OF <i>SARGASSUM MUTICUM</i> ?	149
SYNTHESIS & CONCLUSION	191
APPENDIX	211
DANKSAGUNG	215
CURRICULUM VITAE	219
EIDESSTÄTTLICHE ERKLÄRUNG	223

SUMMARY

Fish use coastal shallow waters, such as the Wadden Sea as nursery and are intrinsically tied on these systems as important predators on benthos and plankton but also as prey for other fish, birds and marine mammals. The composition of the fish community in the Wadden Sea varies not only with the season but also with many other environmental changes, as this unique landscape is constantly being formed and changed by tidal currents, the exchange of water with the adjacent North Sea and the discharge of rivers and streams. Beside these local factors, large scale climatic oscillations, such as the North Atlantic Oscillation (NAO), influence the climate and abiotic characteristics of the Wadden Sea. In succession abiotic characteristics define the species composition and abundance in the habitat Wadden Sea.

As the Wadden Sea represents a very dynamic and open habitat, species might be easily introduced and by successful reproduction become invasive, which may affect native species and in the course of time the food web. If invasive species occur in high abundances and dense aggregations new habitats may be formed. The occurrence of these bioengineer species can cause changes in local habitat characteristics and may impact the whole ecosystem. In the Wadden Sea two bioengineer species, the mollusc *Crassostrea gigas* (Pacific oyster) and the algae *Sargassum muticum* (Japanese wireweed), form new habitats, oyster reefs and dense algal forests respectively.

To investigate the impact of changing abiotic characteristics and the occurrence of invasive species on the ecosystem Wadden Sea, the following work plan was conducted. To uncover possible ongoing changes fish were chosen as the organismic subject group of the study. Fish are able to avoid unfavorable conditions by migration to other areas, indicating ongoing changes. They are also important as consumer components and links between different trophic levels in the food web of the Wadden Sea.

In Chapter I the fish community of a Wadden Sea area was investigated monthly over a period of 5 years to estimate species occurrence and abundance. The effect of local abiotic factors and NAO on the fish community were observed and calculated. To reveal the importance of presence or absence of an abundant fish species for the functioning of the food web, an Ecological Network Analyses (ENA) was conducted in Chapter II.

Due to the fact that new habitats are formed by invasive species the occurrence and abundance of fish species in these new habitats was compared to the fish abundance in sandy habitats in Chapter III. To reveal the energy transport inside a *S. muticum* forest and the possible effects for the whole food web in Chapter IV an ENA was conducted considering various meio- and macrofauna species.

Results show that changing abiotic factors together with large scale climate oscillations impact fish depending on their temperature preference, but also on the vertical habitat in which species forage. Changing conditions may cause changing species composition and impact the food web, as shown in Chapter I and II. Concerning the results of ENA the presence or absence of fish in the food web, is an important factor for energy transport, as in the absence less energy is transported to higher trophic levels. The occurrence of new habitats, e.g. *S. muticum* forests, may be beneficial for rare fish species dependent on subtidal vegetation (Chapter III) formed by native plant canopies that have been lost in the past in the Wadden Sea. Furthermore, in the new habitat other invasive species represent suitable and abundant prey items proving to be beneficial for native fish species as shown in Chapter IV.

In summary the here presented results investigate and reveal the relationships of ecosystem processes and invasive species in relation to the fish community. Revealing impacts and

factors influencing the fish community might help to estimate future developments and changes in Wadden Sea areas.

ZUSAMMENFASSUNG

Fische nutzen flache Küstengewässer, wie das Wattenmeer, als Kinderstube und Aufwuchsgebiet. In ihrer Rolle als Räuber von Benthos und Plankton oder als Beute von anderen Fischen, Vögeln und Seesäufern sind sie aber auch eng mit diesen Systemen verwoben. Im Wechsel der Jahreszeiten wird das Ökosystem Wattenmeer ständig durch lokale Einflüsse, wie den Gezeiten, den Wasseraustausch mit der Nordsee und den Eintrag von Flüssen geformt. Daher unterliegt die Zusammensetzung der Fischgemeinschaft des Wattenmeeres stark saisonale Schwankungen, aber auch vielen anderen Umweltfaktoren. Neben diesen lokalen Einflüssen wirken abiotische Faktoren, wie das Klima, beeinflusst durch großräumige klimatische Oszillationen, wie z.B. der Nord Atlantische Oszillation (NAO). Die abiotische Faktoren, das Klima eingeschlossen, bestimmen wiederum die Artzusammensetzung und Verteilung im Wattenmeer.

Da das Wattenmeer einen offenen und sich verändernden Lebensraum darstellt, ist das Einwandern von neuen Arten möglich. Wenn sich eine eingewanderte Art erfolgreich ausbreitet, wird diese als invasiv bezeichnet. Invasive Arten können mit heimischen Arten interagieren und so im Laufe der Zeit das gesamte Nahrungsnetz beeinflussen. Eingewanderte Arten die in großer Anzahl auf engem Raum vorkommen und so dichte Aggregate bilden, werden als Bioingenieur-Arten bezeichnet. Bioingenieur-Arten können durch ihre große Anzahl lokale abiotische Faktoren beeinflussen und so Ökosysteme nachhaltig beeinflussen.

Im Wattenmeer finden sich zwei eingewanderte Bioingenieur-Arten besonders häufig, die pazifische Auster *Crassostrea gigas* und die Japanische Braunalge *Sargassum muticum*. Diese beiden invasiven Arten bilden dichtbesiedelte Austernriffe und Algenwälder und somit neue Habitate im Wattenmeer.

Um den Einfluss und die Auswirkungen von veränderten abiotischen Parametern und das Auftreten von invasiven Arten auf das Ökosystem Wattenmeer aufzudecken, wurden die nachfolgenden Untersuchungen durchgeführt. Fische wurden dabei als eine Art Indikator gewählt, da diese schnell auf ungünstige Bedingungen reagieren können, z.B. durch Abwandern in andere Gebiete. Ungewöhnliche Schwankungen des Vorkommens und der Anzahl von Fischarten können so einen Hinweis auf veränderte Bedingungen in einem bestimmten Gebiet geben. Fische stellen außerdem wichtige Bestandteile im Nahrungsnetz dar, da sie als Bindeglied zwischen niedrigen und höheren trophischen Stufen im Nahrungsnetz des Wattenmeeres fungieren.

In Kapitel I wird die monatliche Untersuchung einer Fischgemeinschaft über einen Zeitraum von 5 Jahren im nördlichen Wattenmeer vorgestellt. Die Einflüsse von lokalen abiotischen Faktoren auf die Fischgemeinschaft und mögliche Korrelationen zu großräumigen klimatischen Oszillationen wurde statistisch berechnet. Der Einfluss und die Bedeutung der Präsenz einer abundanten Fischart im Nahrungsnetz und für den Energietransport wird mit Hilfe der Ecological Network Analysis (ENA) in Kapitel II dargestellt.

In einem weiteren Schritt (Kapitel III) wird untersucht welche Fischarten sich in neuen, von Bioingenieur-Arten gebildeten Habitaten, finden und aufhalten. Die Abundanz von Arten wird mit verschiedenen Methoden in sandigen Habitaten und in den Algenwäldern von *S. muticum* untersucht. Um den Transport von Energie und mögliche Effekte auf das gesamte Nahrungsnetz des Wattenmeeres abschätzen zu können, wird in Kapitel IV eine ENA vorgestellt, welche sich auf das Nahrungsnetz eines *S. muticum* Waldes konzentriert. Ergebnisse der hier vorgestellten Arbeiten zeigen, dass Fischarten nach ihrer Temperaturpräferenz, aber auch nach ihrem bevorzugten Habitat innerhalb der Wassersäule von abiotische Faktoren im Zusammenspiel mit großräumigen klimatischen Oszillationen

unterschiedlich beeinflusst werden. Veränderte abiotische Faktoren führen zu einer sich ändernden Artgemeinschaft und können somit das Nahrungsnetz nachhaltig beeinflussen (Kapitel I und Kapitel II). Die Ergebnisse der ENA zeigen besonders die Bedeutung der An- bzw. Abwesenheit von abundanten Fischarten für das Nahrungsnetz, da in deren Abwesenheit weniger Energie zu höheren trophischen Stufen transportiert wird. Das Vorkommen und die Etablierung von neuen Habitaten, z.B. Algenwälder, können durchaus vorteilhaft für Fischarten sein. Besonders seltene Fischarten und Fische, die auf Pflanzenbestände in flachen sublitoralen Bereichen angewiesen sind, scheinen von den neuen Habitaten zu profitieren (Kapitel III), da die Bestände entsprechender einheimischer Pflanzen im Wattenmeer in der Vergangenheit verschwunden sind. In Kapitel IV wird außerdem aufgezeigt, dass innerhalb der neuen Habitate, abundante Arten vorkommen, die von Fischen bejagt werden, und sich so als neue verfügbare Beute und Energieressource positiv auf heimische Fischarten auswirken (Kapitel IV).

Die hier vorgestellten Ergebnisse decken das Zusammenspiel und die Beziehungen von Ökosystemprozessen und invasiven Arten auf und stellen diese in Relation zur heimischen Fischgemeinschaft. Die Ergebnisse dieser Arbeit tragen dazu bei zukünftige Entwicklungen und Änderungen im Ökosystem Wattenmeer besser abschätzen zu können.

GENERAL INTRODUCTION



Pictures p. 1 Habitat and species in the Wadden Sea. Top: tidal flats during low tide; Middle: *Arenicola marina* (lugworm) and *Carcinus maenas* (green shore crab); Bottom: swarm of birds, the tidal flats of the Wadden Sea depict important stopovers for migrating birds
Source and copyright Christian Höfs

General Introduction

1.1. Ecosystems of the Wadden Sea

This investigation was conducted in the Wadden Sea, a part of the North Sea situated along the coast of Denmark, Germany and the Netherlands. The area presents a landscape influenced by the tidal rhythm of the adjacent North Sea (Gätje and Reise, 1998). Tidal water movements cause intertidal areas to fall dry during low tide and the seafloor lays barely exposed to solar irradiation, precipitation and air temperature (Gätje and Reise, 1998).

Standing at the shore of the Wadden Sea the eye meets a unique landscape which might to the unperceptive observer appear sparse with turbulent waters and deserted tidal flats. Only different species of birds seem to be abundant, while blue mussels (*Mytilus edulis*) and Pacific oysters (*Crassostrea gigas*) form vast beds and reefs. On the second glance one might discover carapaces of the green shore crab (*Carcinus maenas*) together with manifold shells of mussels washed along the beach probably preyed by crustaceans, fish and birds. Walking further towards the water over the tidal flats little heaps of sediment, discarded by the lugworm (*Arenicola marina*) and trails together with shells of the common periwinkle snail (*Littorina littorina*) can be found. In tidal pools amphipods and other small crustaceans hide under algae attached to shells and small rocks. When approaching the shallow subtidal areas fish of the genus *Pomatoschistus* spp. and the brown shrimp (*Crangon crangon*) dash apart. In deeper waters the silver glittering of juvenile herring (*Clupea harengus*) shoals can be observed feeding on planktonic organisms, in turn providing energy and food for piscivore fish, birds and marine mammals. This short insight hints to a landscape with a diverse species composition inhabiting different ecosystems. These ecosystems are open systems interrelated to and affected by each other (Forman, 1995; Odum and Barrett, 1971).

An ecosystem is defined as “a special explicit unit of the earth that includes all of the organisms, along with all components of the abiotic environment within its boundaries” (Likens, 1992; Tansley, 1935). This special unit or location is defined by regional climatic conditions which in turn are influenced by insolation and large scale oscillating atmospheric systems, e.g. the Arctic Oscillation (AO), the Atlantic Multidecadal Oscillation (AMO) and the North Atlantic Oscillation (NAO) (Nye et al., 2013; Ottersen et al., 2001). Although ecosystems are continuously changing, evolving and fluctuating due to climate oscillations and other impacts, conditions are characteristic and ecosystems provide certain goods and services to inhabiting species, such as regulating climate, providing habitat and food resources (Christensen et al., 1996; Fischlin et al., 2007). An ecosystem might provide a buffer towards disturbances, caused by natural and/or anthropogenic impacts, and it shows certain resilience after the disturbance. However, if disturbances are too impetuous the system will stay in an alternative more fragile state with less resilience (Scheffer et al., 2001). In this fragile state, further disturbances might cause a collapse of the ecosystem, detraction of services and stronger fluctuations of abiotic factors. Changing conditions result in a disconnection of food chains and in an instable system (e.g. Wunderle and Wiley 1996; Scheffer et al. 2001; Vitousek et al. 1997a). The change of abiotic and biotic conditions force species to adapt to their new environment or if adaption is impossible to migrate into areas where more favorable conditions prevail (e.g. Pörtner et al. 2001; Perry et al. 2005; Collie et al. 2008).

Species migration and the introduction of new species into a community may lead to profound alterations regarding species composition and abundance. Trophic interactions will change and additionally new parasites and diseases may be introduced (Bosman et al., 2011; Frank et al., 2005; Naylor et al., 2005; Scheffer et al., 2005). Moreover introduced species

might induce habitat alterations and affect abiotic factors by high individual abundance (Britton-Simmons, 2004; Ruesink et al., 2005).

Beside the above mentioned large scale climate influences ecosystems are constantly under pressure due to anthropogenic impacts, resulting in major shifts at a fast pace (Christensen et al., 1996). Especially marine coastal areas and habitats are directly and indirectly altered and affected, as 37% of the world population inhabits these areas (Cohen et al., 1997; Worm et al., 2006). Human impact extends from hunting, fishing, exploitation of sessile organisms to alterations of nutrient cycles, pollution and beyond to habitat transformation and destruction (Vitousek, 1997b; Jackson et al., 2001; Lotze et al., 2006). The definition of destructive human effects on ecosystems is still under discussion. Human impacts are described as an external interference, such as a storm or other forces of nature, due to the decoupling and independence of humans on ecosystem processes (Wadden Sea Symposium Leeuwarden, 2012). In contrast, Boyden (1993) and Leguerrier et al. (2004) describe humans as part of the ecosystem acting as regular predators (Castilla, 1999; Boer and Prins, 2002). However human activities lead to the loss of 67% of wetlands, 65% of seagrass and 48% of other subtidal plant canopies (Lotze et al., 2006). Furthermore 30% of coral reefs are threatened and until 2030 estimates predict the disappearance of up to 60% of reefs (Hughes et al., 2003; Wilkinson, 2004). The destruction of the above mentioned submerged aquatic habitats together with the exploitation of oceanic predators and the immense fishing pressure lead to the decline and extinction of species (Cox et al., 2002; Dulvy et al., 2004; Myers and Worm, 2005; Pauly et al., 2002; Springer et al., 2003).

For about 2500 years also the landscape and ecosystems of the Wadden Sea are altered by humans and the Wadden Sea is nowadays one of the most impacted ecosystems (Lotze et al., 2006, 2005). While first human settlements impacted habitats only on a regional scale, in

the course of time human population increased going along with a shift of the Wadden Sea to a more simplified system and the decline of species diversity, goods and services (Lotze et al., 2005). Reasons for the simplification are the loss of tidal marshes, aquatic plant canopies and primary production, further the decrease of retention- and filter capacities by dredging and channelisation of rivers and creeks together with the construction of dikes and weirs. These measures changed a once self-sustaining Wadden Sea, to an ecosystem depending mostly on energy import from the adjacent North Sea (Asmus, 1994; Reise, 2005).

1.2. Climate in the Wadden Sea area

The Wadden Sea has a special climate as abiotic and biotic parameters are affected by various features, such as the influence of the North Sea, strong tidal currents and water movements, the discharge of large and small rivers and land-based impacts (Bolle et al., 2009). On a larger scale the NAO is one of the major climate impacts on the North Sea and Wadden Sea and relationships between this large scale climatic oscillation and biotic changes have been observed (Edwards et al., 2002; Rogers, 1984; Weijerman et al., 2005).

The NAO was first described by Walker and Bliss (1932), who hypothesised that changes of sea surface temperature (SST) and abiotic parameters are outcomes of the NAO and defined the NAO index. This index is calculated out of measurements of atmospheric pressures at sea level between Iceland and the Azores. While positive NAO indices indicate stronger storms and warmer SST, negative indices characterise weaker winds and colder SST in winter and spring (Ottersen et al., 2001). The influence and impacts of NAO changes are described for different taxa and trophic levels (e.g. Wiltshire and Manly 2004; Kröncke et al. 2011). Regarding the whole North Sea and Wadden Sea, regime shifts due to large climate fluctuations result in changes of biotic and abiotic factors and are described by several

authors (Reid et al., 2001a; Beaugrand, 2004; Weijerman et al., 2005). The term “regime shift” is not clearly defined, but may be explained following Young et al. (2004) as an “abrupt, persistent change occurring at large spatial scales, observed at different trophic levels and related to climate forcing”.

Focusing on certain levels in the food web Edwards et al. (2002, 2006) found positive correlations for certain phytoplankton species with NAO and SST. Edwards et al. (2002) and Wiltshire and Manly (2004) found changes in the copepod fauna following climate patterns. As lower trophic levels are impacted, higher trophic levels might be affected as well (Kröncke et al. 2011). Attrill and Power (2002) demonstrated significant relationships between the NAO index and nine fish species.

Other investigations regarding fish gave significant relationships between abundance, growth and the NAO (Henderson, 2007; Henriques et al., 2007). On species level (Sims et al., 2004) described a change in the beginning of the spawning migration of *Platichthys flesus* depending on prevailing NAO. Henderson and Seaby (2005) correlated abundance and growth of *Solea solea* to NAO and found significant relationships especially concerning juvenile growth. Other publications show changing species compositions, abundances and migration patterns being related to large scale climate changes (Corten and Kamp, 1996; Corten, 1990; Lindeboom et al., 1995; Reid et al., 2001). Delays of effects of NAO of up to 12 months, influencing the abundance of *Pomatoschistus microps*, are described by Nyitrai et al. (2013).

Large scale climate oscillations together with anthropogenic pressures and the introduction of new species influence and change the fish fauna in the North Sea and Wadden Sea. Changing species compositions and abundances can alter trophic interactions which in turn affect the food web and energy transport in the ecosystem.

1.3. Invasive and bioengineer species

Before the nature of food webs, direct and indirect trophic relationships and the estimation of energy transport are explained, the possible impacts of introduced, invasive and bioengineering species will be described. The introduction of species into ecosystems or habitats might happen intendedly or by accident mostly by human activities. In case the species is able to survive, reproduce and disperse in the new environment it may become invasive (Cagri, 1990; Kolar and Lodge, 2001). A species might be a potential and successful invader if it reproduces quickly and numerous, survives long distance transports and is introduced into an ecosystem with unused resources and unoccupied habitats (Cagri 1990; Reise 1998).

Introduced and invasive species may affect ecosystems and native species directly or indirectly, e.g. via predator-prey interactions, parasitism or introduction of parasites, competition for habitat, space and food or impacting resources on which native species depend (Vitousek, 1990; Vitousek et al., 1997c; Crooks, 1998). The impact of a new species on an ecosystem and its components might be stronger if a bioengineering species is able to establish a self-sustaining population, because ecosystem engineers change the accessibility and abundance of resources and habitats for other species (Jones et al., 1994). Ruesink et al. (2005) report of about 78 successfully established invasive species of different taxa following the cultivation of non-native oysters.

Habitat generating species may alter the new environment in two ways, either by autogenic or allogenic engineering (Jones et al., 1994). While autogenic engineering species modify a habitat by their own structure, e.g. dense macroalgae canopies and seagrass beds, allogenic engineers “transform living or non-living material from one physical state to another”, e.g. the lugworm *Arenicola marina* (Bouma et al., 2009; Volkenborn et al., 2007). Complex

habitats formed by bioengineers, such as seagrass beds, provide important nursery areas and foraging grounds for various species (Polte and Asmus, 2006). Bioengineering species are forming habitats, and affecting water quality, as oysters and dense plant canopies acting as sinks for fine sediments and changing nutrient concentrations (Asmus and Asmus, 1998; Crooks, 1998; Reise, 2005).

1.4. Invasive species in the Wadden Sea

Until 2010 up to 66 introduced species were found in the Wadden Sea and most of them seem to be well established (Buschbaum et al., 2012). The introduction of new species might be enhanced by climate change and increasing water temperatures (Nehring et al., 2009; Walther et al., 2009).

The Pacific oyster *Crassostrea gigas* is today one of the most abundant introduced species along the European coasts (Buschbaum et al., 2012; Nehls and Büttger, 2007). The Pacific oyster originates from Japan and was introduced to European waters in the 1970's (Den Hartog 1997). In the northern Wadden Sea cultivation started in 1986 as a compensation for the overexploited European flat oyster *Ostrea edulis* (Reise, 1998). The Pacific oyster overgrew beds of the blue mussel *Mytilus edulis*, becoming one of the most abundant invertebrates in inter- and shallow subtidal areas of the Wadden Sea. The individual size may reach up to 200 mm and an abundance of up to 1829 ind m⁻² were found in 2007, followed by a decline to 69 ind m⁻² in 2010, possible due to cold winter temperatures (Büttger et al., 2011). After the introduction of *C. gigas* in Europe the establishment of the Japanese seaweed *Sargassum muticum* was predicted by (Druehl, 1973). Today *S. muticum* is a common species along European coasts forming dense algae forests with up to 9 individuals m⁻² and a biomass of around 4000 g m⁻² (Critchley, 1990; Critchley 1990a). The reproduction

cycle of *S. muticum* is shown in Fig. 1. The Pacific oyster and Japanese seaweed are both described as engineering species impacting the environment by their high individual abundance and the formation of biogenic structures (Britton-Simmons, 2004; Leguerrier et al., 2004). The impact of these new structures on the Wadden Sea ecosystem cannot be clearly answered. Markert et al. (2010) found higher abundance and species richness of macrofauna on oyster reefs compared to beds of the blue mussel and open sand flats, probably caused by increased habitat complexity and extended hard substrate by oyster shells. *Sargassum muticum* colonising areas with low macroalgae cover, provide new habitats for epifauna, which again attract fish resulting in an increased secondary production (Fernández et al., 1990; Viejo, 1999).

Polte and Buschbaum (2008) conclude that dense canopies of introduced algae might present an alternative to lost native subtidal seagrass habitats of *Zostera marina*. This seagrass species was decimated due to the infection and outspread of the slime mold *Labyrinthula* sp. and anthropogenic impacts (Den Hartog, 1987). Den Hartog (1997) also states that *S. muticum* might be a threat to remaining *Z. marina* beds on coarse sediments, as rhizoids of the brown algae settle and grow on formerly covered areas by *Z. marina* and prevent a reestablishment of the seagrass. Buschbaum et al. (2006) discuss that *S. muticum* forests might provide a new habitat for red algal species which became rare in the Wadden Sea due to human impact. Stæhr et al. (2000), Lang and Buschbaum (2010) describe the competition between native algae and *S. muticum*:

Sargassum muticum may have positive effects on the biodiversity as the thalli host numerous epibiotic species. On the other hand a decreasing abundance of single native algae was observed being dependent on oyster beds as substrate to settle, possible due to shading by *S. muticum* and accordingly reduced irradiation (Britton-Simmons, 2004; Lang

and Buschbaum, 2010). Also the dispersal and high abundances of the introduced amphipod *Caprella mutica* might be associated with the occurrence of *S. muticum*, as algal forests provide habitat for *C. mutica* and specimens are transported on drifting thalli to new areas (Buschbaum and Gutow, 2005). Until now few data are available on how introduced species affect energy transport and food webs in Wadden Sea areas. Current analyses and publications as well as the calculations of energy transport using ecological network analyses are presented in this thesis.

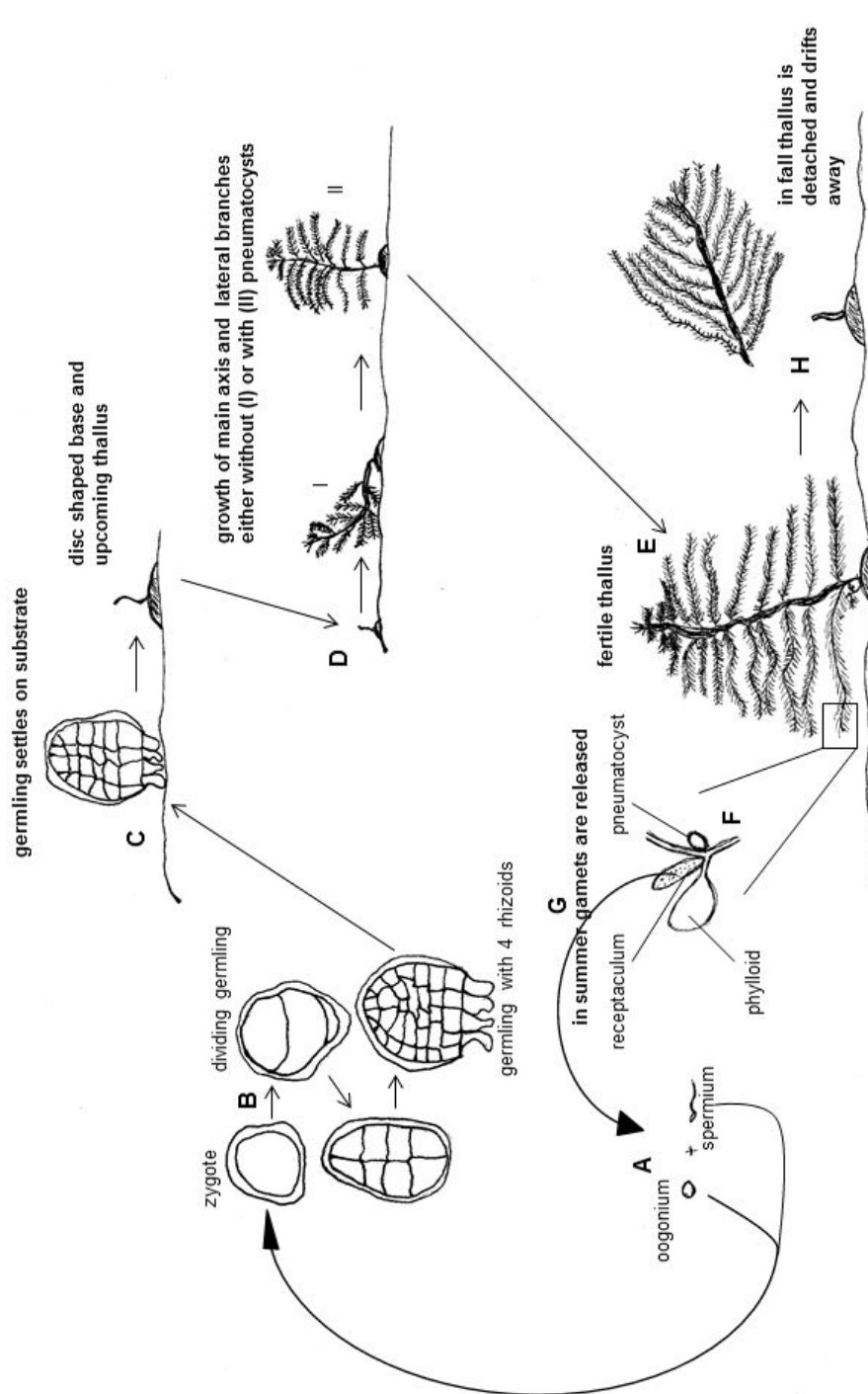

Fig. 1. **A:** The oogonium is fertilised by the spermium and a zygote develops. **B:** Two transversal constrictions form a three cell germling, which divides into 8 compartments, followed by further partitions. On the basis the basal cell develops into 4 rhizoids, enabling the germling to settle on substrate. **C:** The germling settles and a disc shaped base, attaching the upcoming thallus to the substrate, is formed. **D:** The attached germing grows, forming a main axis and lateral branches. **E:** Detail drawing of a lateral branch and properties, showing the phylloid, the receptaculum and the pneumatocyst. **F:** In summer the fertile individual releases the oogonium and spermium which develop to the zygote attached to the receptaculum and are released when rhizoids are full-grown. **G:** The attached germing grows, forming a main axis and lateral branches. **H:** In fall the thallus is detached and drifts away. Modified after Jephson and Gray (1977), Norton (1977), Britton-Simmons (2004), Peters (2004), Engelen and Santos (2009).

1.5. Ecological Network Analyses

1.5.1. Historical background and development

In the 1970`s, new applications to evaluate ecological processes based on the Input-Output analyses and information theory were published (Hannon 1973, Finn 1976, Patten et al. 1976). Input-Output analyses form the first pillar of modern Ecological Network Analyses (ENA). The theory of Input-Output analyses was first published by Leontief (1936) and was a modelling approach to explain mainly economic processes. It indicates how much energy, effort and material (input/source) is needed to produce a certain good (output/product). The analyses can be used backwards (Leontief, 1936), based on the product to estimate the source or forward (Augustinowicz, 1970), describing changes from the source towards the product. The second pillar, information theory (Shannon, 1948), includes data transmission and the filtering of signals and content from the background noise.

Applying the suggestions of the new techniques to ecology, published by Hannon (1973), Finn (1976) and Patten et al. (1976) the Scientific Committee on Oceanic Research (SCOR) established the workgroups 59 (Mathematical Models in Biological Oceanography) and 73 (Ecological Theory in Relation to Biological Oceanography). The publications of these workgroups encourage scientists to consider not only species diversity and biomass in ecological systems, but to include ecological processes and especially trophic interactions in their investigations (Fasham, 1984). Following these results the systematic approach to analyse biological material and energy transports as well as the investigation of ecological networks and the construction of network models was described by Ulanowicz (1986), Wulf and Ulanowicz (1989) and Christian and Ulanowicz (2002). Today, ENA provides an approved instrument to illustrate processes and changes in ecosystems and to reveal the possible

consequences and reasons of ongoing transformations (Coll and Libralato, 2012). To conduct ENA mostly one of the two following programs is employed, either NETWRK (Ulanowicz and Kay, 1991) or ECOPATH with ECOSIM (EwE) (Christensen and Pauly, 1992), developed after (Polovina, 1984) and (Christian and Ulanowicz, 2002).

1.5.2. Benefits, basic principles and requirements to conduct ENA

Calculations of ecological networks represent interactions between the various groups of an ecosystem and reveal the direction and magnitude of energy flows in a system (Heymans et al., 2007; Libralato et al., 2006). Hannon (1973) explains in the following simplified example the effectiveness and benefits of ENA: The energy flows between the sun (energy source), grass (primary production), zebras (herbivores) and lions (carnivores) are easy to quantify via observation. Grass grows by means of photosynthesis, zebra graze and the lions prey on zebra. The parameters defining this system can be measured, the import, e.g. irradiation of the sun, the export of energy, e.g. the respiration of the various groups, as energy per area and time, the biomass, consumption and egestion in mass per area. These observations might help to understand how the system works, but no conclusions can be drawn about the quantitative interactions between the various groups. How dependent are carnivores on the irradiation of the sun? Do energy flows vary over the course of time? How stable are energy flows and the food web? Is it possible to compare energy flows in the investigated system to similar systems?

Employing ENA enables scientists to answer the above questions and helps to understand how a system might react after transformations and if perturbation of certain energy flows can cause a collapse of the whole system. The knowledge how a system might react towards perturbation might help to develop effective measures to preserve this system. Ulanowicz

(2004) states that ENA allows to get insights into direct and indirect flows of energy, further connections and interactions between the different groups and the trophic position of every component in the food web can be revealed.

To analyse energy flows quantitatively in a food web, it is necessary to define compartments or aggregate them into functional groups, and to observe the interactions between these groups. The precision and definition of a compartment depends on the investigator and the available data. A compartment might be a single species, a genus, a class or a functional group, e.g. detritus feeders or zooplankton. To evaluate the material and energy flows between the single compartments, either data for the particular investigation may be sampled or if sampling is not possible data from previous sampling campaigns and available literature can be used. Following the above mentioned approaches the analysis of a food web model is based on empirical data, which were obtained by observations or experiments, and represents a realistic representation of an ecosystem (Field et al., 1989; Kay et al., 1989). To establish a quantitative food web model, biomass, respiration, consumption, egestion and energy flows of all compartments are required, furthermore imports and exports of energy from adjacent systems needs to be included in the analysis (Johnson et al., 2009) (Fig. 2).

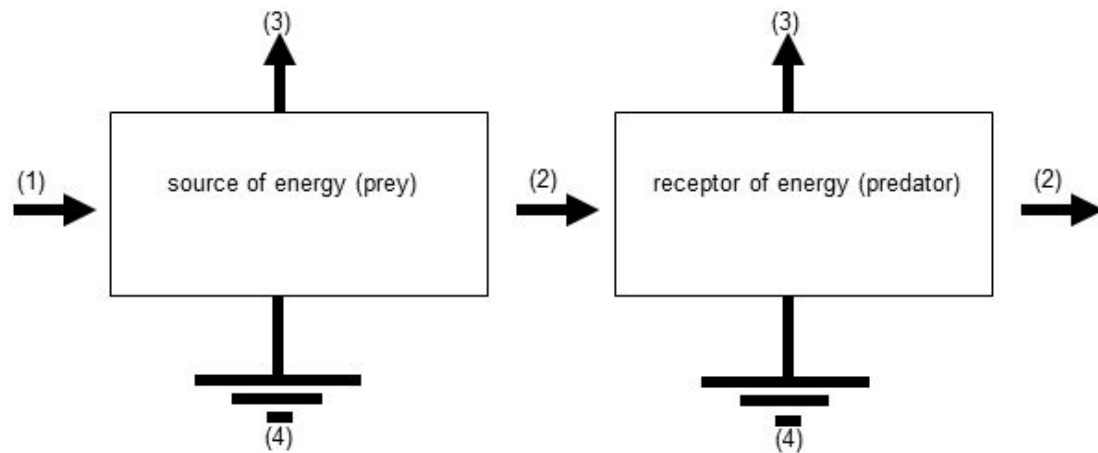

Fig. 2 Four possibilities of energy flow in an ecosystem. (1) Exogene inputs (e.g. solar irradiation); (2) interaction and exchange between compartments (e.g. predation); (3) export of organic material (e.g. ripped off and drifting plant material); (4) deflection of anorganic material (e.g. CO₂ lost by respiration) (after Asmus pers. comm.).

1.5.3. Evaluation of ecosystem properties

Although ecologists avoid evaluating ecosystem properties and processes, humans tend to rank properties and to manage them according to their assessment. Farber et al. (2002) discuss the evaluation of ecosystem properties and processes: how valuable are ecosystem services, e.g. a well-functioning and species rich ecosystem, natural habitats or good water quality? The authors further present different approaches of evaluation: an example formulated by Aristoteles shows, the value of water, although necessary to survive, has an undefined, lower trade value compared to a diamond, which might gild life, but is not necessary to live. Around 1740 Galiani described the evaluation of goods as a comparison of their relation towards the usability and availability of other goods: a diamond might not be useful as water, but it is rare (Schumpeter, 1978). In the same period Smith included the effort of work in the definition of the value. If hunting of a beaver needs twice the effort of slaying a deer, then a beaver will be considered to be more valuable than a deer (Schumpeter, 1978). Today values for goods are mostly estimated on a monetary basis. Mere economic ecosystem approaches seeking to increase the productivity of certain ecosystem

components as in aquaculture or agriculture, might be a reason for decreasing biodiversity (Christensen et al., 1996). Furthermore key processes may be interrupted and this might cause a destabilisation of a system (Christensen et al., 1996). In the Wadden Sea *Crassostrea gigas* cannot be easily preyed, due to the large size and thickness of the shell. In this way it represents a dead end in the food chain. Most professional fishermen will use the work/effort which is necessary to catch a certain species and the market value to define the importance of species. Tourism industry might appraise charismatic species like marine mammals as a possible source of income and accordingly judge these species as important parts of an ecosystem. Rare species are often assumed to be valuable, like diamonds, regardless of ecological function and importance.

In biological sciences and coastal management the evaluation is more complex, as biodiversity- or habitat-diversity of an ecosystem cannot easily be assessed according to human priorities. Recent efforts, such as the water framework directive of the European Union will help to classify the condition of water habitats. According to Farber et al. (2002), the ecological importance of a system's component can be quite different from the economic value. Farber et al. (2002) conclude further that survival and reproduction of species are supported by suitable habitats and other organisms, such as prey items. These habitats and prey organisms constitute a "value" for the specific species. A holistic approach like ENA can help to evaluate the actual importance of functions and components in an ecosystem, regardless of human priorities and unaffected by economic considerations. An example: after the loss of *Ostrea edulis*, *C. gigas* was cultivated as a substitute in the Wadden Sea and along the Atlantic coast. In economic terms both species are important marketable goods, implying from a human point of view that both species might have the same value. Different ecological functions of the two species and the impact of the new,

introduced *C. gigas* on other species and the energy flow in the ecosystem can only be revealed employing a holistic approach. To conclude, employing ENA is a way to unravel the ecological value and importance of any part of the food web.

1.5.4. The concept and identification of keystone species

Although it is highly beneficial to apply an analytical system like ENA, Mace (2004) criticises management strategies based on holistic approaches instead of monitoring of single populations. These may lead to the loss of focus on certain species and populations. Nevertheless he states that merely population monitoring is not sufficient to clarify how a particular species is integrated into an ecosystem. The program IMPACT (Christensen et al., 2008; Ulanowicz and Puccia, 1990) may be applied in order to evaluate the impacts of ecosystem components on the populations of a specific species within the food web and vice versa. This program investigates all connections, interactions and impacts of a species in the whole interplay. In this way the observer is able to reveal direct as well as indirect interactions and moreover the importance or keystone species in the food web can be elucidated.

The concept of keystone species was first presented by Paine (1969) who investigated the effect of the abundance of a starfish (*Pisaster ochraceus*) preying on herbivore molluscs. He concluded that in the presence of the predator (*P. ochraceus*) the abundance of molluscs remains low so that the ecologically important algal forests are prevented from being fed down. Throughout time this concept was adapted and complemented. Power et al. (1996) define a keystone species as a component of an ecosystem with low biomass and abundance, but a great impact on other ecosystem components. Davic (2003) defines a keystone species as a species within a certain functional group (e.g. detritus feeders) that

dominates in terms of biomass. Coll and Libralato (2012) define keystone species, as the ones who impact other species by their abundance.

In order to calculate the impact of species in an ecosystem and to define possible keystone species, the program EwE employs the routines developed by Libralato et al. (2006). These routines calculate all direct and indirect impacts of a species on all other species. The resulting number is multiplied with the ratio of biomass over the total biomass of this species. This procedure is executed for all species included in the investigation. For every species calculations result in a value between 0 and 1, values close to 1 indicate a keystone species.

Davic (2003) points out calculations identifying keystone species should be considered with caution because the concept of keystone species is very wide and not well defined. Despite considerable concerns, the presented routine depicts reliable methods to classify living components of the ecosystem according to direct and indirect interactions. Single components are not classified according to human interests, but in fact following actual ecological interactions. Furthermore all living components in the ecosystem are considered in the calculations, enabling investigators to obtain an overall view of the whole ecosystem.

1.6. Fish important components and indicators in ecosystems

Fish are an important food resource for humans, as in 2012 alone, 60998 tons of marine fish were caught world-wide (FAO, 2012). They provide vital ecosystem services and represent accordingly important components in the system (Holmlund and Hammer, 1999). The presence or absence of certain feeding types of fish (e.g. herbivores, zooplanktivores, piscivores) influences the food web, the energy transport and changes the biomass as well as the productivity of other taxa. In this way central characteristics of a system may be

determined by fish (Carpenter et al., 1985). The spawning activity of fish can alter the environment, which helps to increase spawning success and provides habitats for other species (Flecker, 1992; Gelwick et al., 1997; Montgomery et al., 1996). For example by burrowing eggs in river sediments the sediment composition is altered, while further feeding activity of fish may increase the resource availability for other organisms, like fish breakup prey, and parts of the prey item drift away and are ingested by other organisms (Flecker, 1992; Gelwick et al., 1997; Montgomery et al., 1996). Via migration fish import nutrients and energy which may increase productivity in ecosystems (Larkin and Slaney, 1997). As fish prey in different areas on various prey items and are preyed by species inhabiting adjacent habitats (e.g. birds) they represent important energy resources in these food webs (Holmlund and Hammer, 1999; Powell et al., 1991). Because fish are main components in ecosystems Whitfield and Elliott (2002) emphasise the importance of investigation of fish species and populations. These studies may result in the development of invaluable ecological indicators in the frame of monitoring programs. Whitfield and Elliott (2002) list the following arguments in favor of studying fish:

- Fish are present in most of the water bodies around the world.
- The taxonomy and morphology of most species is well known and species can be easily identified and investigated *in situ*.
- Fish are found in different trophic positions, representing lower and upper levels in a food web.
- Fish occupy different habitats, forage in various ways and represent different life forms, which may help to find conclusions for a major part of the investigated ecosystem and food webs.

-
- Most fish species are well studied and data of the ontogeny, life cycle and behavior is available, enabling investigators to observe changes and influences of environmental stressors.
 - Fish are a matter of public and economic interest, which might help to increase the conservation consciousness of a broad public and arouse interest towards environmental processes. The economic interest might help to fund investigations and monitoring programs.

In addition to beneficial arguments, Whitfield and Elliott (2002) specify problems arising in investigations of fish:

- The occupation of different habitats and different life forms necessitates major sampling efforts employing various sampling gears.
- As many fish species are mobile and abundant in different seasons of the year, sampling may be biased. Fish may avoid stressors and unfavorable conditions by simply migrating, precluding sampling.
- Environmental stressors may be overseen, as fish species can be tolerant towards the disturbances, while other taxa are strongly influenced.
- The reaction towards stressors might be delayed, as polluted or anthropogenically influenced systems can still be populated by a species rich fish community.

The authors conclude that although investigators should be aware of the mentioned problems, the benefits of including fish in monitoring programs clearly prevail.

References General Introduction

- Asmus, H., 1994. Benthic grazers and suspension feeders: which one assumes the energetic dominance in Königshafen? *Helgol. Mar. Res.* 48, 217–231.
- Asmus, H., Asmus, R., 1998. The role of macrobenthic communities for sediment-water material exchange in the Sylt-Rømø tidal basin. *Senckenbergiana maritima* 29, 111–119.
- Attrill, M.J., Power, M., 2002. Climatic influence on a marine fish assemblage. *Nature* 417, 275–278. doi:10.1038/417275a
- Augustinowic, M., 1970. Methods of international and intertemporal comparison of structure, in: Carter, A., Brody, A. (Eds.), *Contributions to Input-Output Analysis*. Amsterdam, pp. 249–269.
- Beaugrand, G., 2004. The North Sea regime shift: evidence, causes, mechanisms and consequences. *Prog. Oceanogr.* 60, 245–262. doi:10.1016/j.pocean.2004.02.018
- Bolle, L.J., Neudecker, T., Vorberg, R., Damm, U., Diederichs, B., Jager, Z., Scholle, J., Daenhardt, A., Lüerßen, G., Marencic, H., 2009. Trends in Wadden Sea fish fauna Part I : Trilateral Cooperation.
- Bosman, S.H., Methven, D.A., Courtenay, S.C., Hanson, J.M., 2011. Fish assemblages in a north Atlantic coastal ecosystem: spatial patterns and environmental correlates. *Estuar. Coast. Shelf Sci.* 92, 232–245. doi:10.1016/j.ecss.2010.12.036
- Bouma, T.J., Olenin, S., Reise, K., Ysebaert, T., 2009. Ecosystem engineering and biodiversity in coastal sediments: posing hypotheses. *Helgol. Mar. Res.* 63, 95–106. doi:10.1007/s10152-009-0146-y
- Boyden, S., 1993. The human component of ecosystems, in: *Humans as Components of Ecosystems*. Springer, pp. 72–77.
- Britton-Simmons, K., 2004. Direct and indirect effects of the introduced alga *Sargassum muticum* on benthic, subtidal communities of Washington State, USA. *Mar. Ecol. Prog. Ser.* 277, 61–78.
- Buschbaum, C., Chapman, A.S., Saier, B., 2006. How an introduced seaweed can affect epibiota diversity in different coastal systems. *Mar. Biol.* 148, 143–161. doi:10.1007/s00227-005-0128-9
- Buschbaum, C., Gutow, L., 2005. Mass occurrence of an introduced crustacean (*Caprella* cf. *mutica*) in the south-eastern North Sea. *Helgol. Mar. Res.* 59, 252–253. doi:10.1007/s10152-005-0225-7
- Buschbaum, C., Lackschewitz, D., Reise, K., 2012. Nonnative macrobenthos in the Wadden Sea ecosystem. *Ocean Coast. Manag.* 68, 89–101. doi:10.1016/j.ocecoaman.2011.12.011

-
- Büttger, H., Nehls, G., Witte, S., 2011. High mortality of Pacific oysters in a cold winter in the North-Frisian Wadden Sea. *Helgol. Mar. Res.* 65, 525–532. doi:10.1007/s10152-011-0272-1
- Carpenter, S.R., Kitchell, J.F., Hodgson, J.R., 1985. Cascading trophic interactions and lake productivity. *Bioscience* 35, 634–639.
- Castilla, J.C., 1999. Coastal marine communities : trends and perspectives from human-exclusion experiments. *Trends Ecol. Evol.* 14, 280–283.
- Castri di, F., 1990. On invading species and invaded ecosystems: the interplay of historical chance and biological necessity, in: Castri di, F., Hansen, A., Debussche, M. (Eds.), *Biological invasions in Europe and the Mediterranean Basin*. Springer, pp. 3–16.
- Christensen, N.L., Bartuska, A.M., Brown, J.H., Carpenter, S., Antonio, C.D., Francis, R., Franklin, J.F., Macmahon, J.A., Noss, R.F., Parsons, J., Peterson, C.H., Turner, M.G., Woodmansee, R.G., Url, S., 1996. The Report of the Ecological Society of America Committee on the scientific basis for ecosystem management. *Ecol. Appl.* 6, 665–691.
- Christensen, V., Pauly, D., 1992. Ecopath II - a software for balancing steady-state ecosystem models and calculating network characteristics. *Ecol. Modell.* 61, 169–185.
- Christensen, V., Walters, C.J., Pauly, D., Forrest, R., 2008. *Ecopath with Ecosim version 6 User Guide*. Lensfest Ocean Futures Project 2008.
- Christian, R., Ulanowicz, R., 2002. Network ecology, in: El-Shaarawi, A., Piegorisch, W. (Eds.), *Encyclopedia of environmetrics*. John Wiley and Sons, Chinchester, pp. 1393–1399.
- Cohen, J.E., Small, C., Mellinger, A., Gallup, J., Sachs, J., Vitousek, P.M., Mooney, H.A., 1997. Estimates of coastal populations. *Science* (80-.). 278, 1209–1213.
- Coll, M., Libralato, S., 2012. Contributions of food web modelling to the ecosystem approach to marine resource management in the Mediterranean Sea. *Fish Fish.* 13, 60–88. doi:10.1111/j.1467-2979.2011.00420.x
- Collie, J.S., Wood, A.D., Jeffries, H.P., 2008. Long-term shifts in the species composition of a coastal fish community. *Can. J. Fish. Aquat. Sci.* 65, 1352–1365. doi:10.1139/F08-048
- Corten, A., 1990. Long-term trends in pelagic fish stocks of the North Sea and adjacent waters and their possible connection to hydrographic changes. *Netherlands J. Sea Res.* 25, 227–235.
- Corten, A., Kamp, van de G., 1996. Variation in the abundance of southern fish species in the southern North Sea in relation to hydrography and wind. *ICES J. Mar. Sci.* 53, 1113–1119.

-
- Cox, S.P., Essington, T.E., Kitchell, J.F., Martell, S.J.D., Walters, C.J., Boggs, C., Kaplan, I., 2002. Reconstructing ecosystem dynamics in the central Pacific Ocean , 1952 – 1998 . II . A preliminary assessment of the trophic impacts of fishing and effects on tuna dynamics. *Can. J. Fish. Aquat. Sci.* 1747, 1736–1747. doi:10.1139/F02-138
- Critchley, A.T., Farnham, W.F., Yoshida, T., Norton, T.A., 1990a. A bibliography of the invasive alga *Sargassum muticum* (Yendo) Fensholt (Fucales; Sargassaceae). *Bot. Mar.* 33, 551–562. doi:10.1515/botm.1990.33.6.551
- Critchley, A.T., Visscher, P.R.M., Nienhuis, P.H., 1990b. Canopy characteristics of the brown alga *Sargassum muticum* (Fucales, Phaeophyta) in lake Grevelingen, southwest Netherlands. *Hydrobiologia* 204-205, 211–217. doi:10.1007/BF00040236
- Crooks, J.A., 1998. Habitat alteration and community-level effects of an exotic mussel, *Musculista senhousia*. *Mar. Ecol. Prog. Ser.* 162, 137–152. doi:10.3354/meps162137
- Davic, R.D., 2003. Linking keystone species and functional groups : a new operational definition of the keystone species concept. *Conserv. Ecol.* 7, response 11.
- De Boer, W., Prins, H., 2002. Human exploitation and benthic community structure on a tropical intertidal flat. *J. Sea Res.* 48, 225–240. doi:10.1016/S1385-1101(02)00160-0
- Den Hartog, C., 1987. “Wasting disease” and other dynamic phenomena in *Zostera* beds. *Aquat. Bot.* 27, 3–14. doi:10.1016/0304-3770(87)90082-9
- Den Hartog, C., 1997. Is *Sargassum muticum* a threat to eelgrass beds? *Aquat. Bot.* 58, 37–41.
- Druehl, L.D., 1973. Marine Transplantations. *Science* (80-). 179, 12.
- Dulvy, N.K., Freckleton, R.P., Polunin, N.V.C., 2004. Coral reef cascades and the indirect effects of predator removal by exploitation. *Ecol. Lett.* 7, 410–416. doi:10.1111/j.1461-0248.2004.00593.x
- Edwards, M., Beaugrand, G., Reid, P.C., Rowden, A.A., Jones, M.B., 2002. Ocean climate anomalies and the ecology of the North Sea. *Mar. Ecol. Prog. Ser.* 239, 1–10.
- Edwards, M., Johns, D.G., Leterme, S.C., Svendsen, E., Richardson, a. J., 2006. Regional climate change and harmful algal blooms in the northeast Atlantic. *Limnol. Oceanogr.* 51, 820–829. doi:10.4319/lo.2006.51.2.0820
- Engelen, A., Santos, R., 2009. Which demographic traits determine population growth in the invasive brown seaweed *Sargassum muticum*? *J. Ecol.* 97, 675–684. doi:10.1111/j.1365-2745.2009.01501.x
- FAO, 2012. Statistics and information branch of the fisheries and aquaculture department 2014 FAO yearbook. Fishery and Aquaculture Statistics. 2012. Rome, FAO.

-
- Farber, S.C., Costanza, R., Wilson, M.A., 2002. Economic and ecological concepts for valuing ecosystem services. *Ecol. Econ.* 41, 375–392. doi:10.1016/S0921-8009(02)00088-5
- Fasham, M.J.R., 1984. Flows of energy and materials in marine ecosystems. *Marine Science*, Plenum Publishing Corporation, New York.
- Fernández, C., Gutierrez, L.M., Rico, J.M., 1990. Ecology of *Sargassum muticum* on the north coast of Spain. Preliminary observations. *Bot. Mar.* 33, 423–428.
- Field, J.G., Wulff, F., Mann, K.H., 1989. The need to analyze ecological networks. *Coast. Estuar. Stud.* 32, 3–12.
- Finn, J., 1976. Measures of ecosystem structure and function derived from analysis of flows. *J. Theor. Biol.* 56, 363–380.
- Fischlin, A., Midgley, G., Price, J., Leemans, R., Gopal, B., Turley, C., Rounsevell, M., Dube, O., Tarazona, J., Velichko, A., 2007. Ecosystems, their properties, goods and services, in: Cramer, W., Diaz, S., Parry, M., Canziani, O., Palutikof, J., van der Linden, P., Hanson, C. (Eds.), *Climate Change 2007: impacts, adaptation and vulnerability. Contribution of Working Group II to the Fourth Assessment Report of the Intergovernmental Panel on Climate Change*. Cambridge University Press, Cambridge, pp. 211–272.
- Flecker, A.S., 1992. Fish trophic guilds and the structure of a tropical stream : weak direct vs. strong indirect effects. *Ecology* 73, 927–940.
- Forman, R.T.T., 1995. Some general principles of landscape and regional ecology. *Landsc. Ecol.* 10, 133–142. doi:10.1007/BF00133027
- Frank, K.T., Petrie, B., Choi, J.S., Leggett, W.C., 2005. Trophic cascades in a formerly cod-dominated ecosystem. *Science* (80-). 308, 1621–1623. doi:10.1126/science.1113075
- Gätje, C., Reise, K., 1998. *Ökosystem Wattenmeer - Austausch-, Transport- und Stoffumwandlungsprozesse*. Springer, Berlin, Heidelberg, New York.
- Gelwick, F., Stock, M., Matthews, W., 1997. Effects of fish, water depth, and predation risk on patch dynamics in a north-temperate river ecosystem. *OIKOS* 80, 382–398.
- Hannon, B., 1973. The structure of ecosystems. *J. Theor. Biol.* 41, 535–546.
- Henderson, P.A., 2007. Discrete and continuous change in the fish community of the Bristol Channel in response to climate change. *J. Mar. Biol. Assoc. UK* 87, 589–598. doi:10.1017/S0025315407052447
- Henderson, P.A., Seaby, R.M., 2005. The role of climate in determining the temporal variation in abundance, recruitment and growth of sole *Solea solea* in the Bristol Channel. *J. Mar. Biol. Assoc. UK* 85, 197–204. doi:10.1017/S0025315405011069h

-
- Henriques, M., Gonçalves, E., Almada, V., 2007. Rapid shifts in a marine fish assemblage follow fluctuations in winter sea conditions. *Mar. Ecol. Prog. Ser.* 340, 259–270. doi:10.3354/meps340259
- Heymans, J.J., Guénette, S., Christensen, V., 2007. Evaluating Network Analysis indicators of ecosystem status in the gulf of Alaska. *Ecosystems* 10, 488–502. doi:10.1007/s10021-007-9034-y
- Holmlund, C.M., Hammer, M., 1999. Ecosystem services generated by fish populations. *Ecol. Econ.* 29, 253–268. doi:10.1016/S0921-8009(99)00015-4
- Hughes, T.P., Baird, A.H., Bellwood, D.R., Card, M., Connolly, S.R., Folke, C., Grosberg, R., Hoegh-Guldberg, O., Jackson, J.B.C., Kleypas, J., Lough, J.M., Marshall, P., Nyström, M., Palumbi, S.R., Pandolfi, J.M., Rosen, B., Roughgarden, J., 2003. Climate change, human impacts, and the resilience of coral reefs. *Science* (80-). 301, 929–933. doi:10.1126/science.1085046
- Jackson, J.B., Kirby, M.X., Berger, W.H., Bjorndal, K.A., Botsford, L.W., Bourque, B.J., Bradbury, R.H., Cooke, R., Erlandson, J., Estes, J.A., Hughes, T.P., Kidwell, S., Lange, C.B., Lenihan, H.S., Pandolfi, J.M., Peterson, C.H., Steneck, R.S., Tegner, M.J., Warner, R.R., 2001. Historical overfishing and the recent collapse of coastal ecosystems. *Science* (80-). 293, 629–37. doi:10.1126/science.1059199
- Jephson, N.A., Gray, P.W.G., 1977. Aspects of the ecology of *Sargassum muticum* (Yendo) Fensholt in the Solent region of the British Isles; I. The growth cycle and epiphytes. *Biology of benthic organisms, Proc. XIth Europ. Symp. Mar. Biol. Galway.*
- Johnson, G.A., Niquil, N., Asmus, H., Bacher, C., Asmus, R., Baird, D., 2009. The effects of aggregation on the performance of the inverse method and indicators of network analysis. *Ecol. Modell.* 220, 3448–3464. doi:10.1016/j.ecolmodel.2009.08.003
- Jones, C.G., Lawton, J.H., Shachak, M., 1994. Organisms as ecosystem engineers. *Oikos* 69, 373–386.
- Kay, J., Graham, L., Ulanowicz, R., 1989. A detailed guide to network analysis, in: Wulff, F., Field, J., Mann, K. (Eds.), *Network analysis in Marine Ecology Coastal and Estuarine Studies Series*. Springer-Verlag, Berlin, pp. 15–61.
- Kolar, C.S., Lodge, D.M., 2001. Progress in invasion biology: predicting invaders. *Trends Ecol. Evol.* 16, 199–204.
- Kröncke, I., Reiss, H., Eggleton, J.D., Aldridge, J., Bergman, M.J.N., Cochrane, S., Craeymeersch, J. a., Degraer, S., Desroy, N., Dewarumez, J.-M., Duineveld, G.C. a., Essink, K., Hillewaert, H., Lavaleye, M.S.S., Moll, A., Nehring, S., Newell, R., Oug, E., Pohlmann, T., Rachor, E., Robertson, M., Rumohr, H., Schratzberger, M., Smith, R., Berghe, E. Vanden, van Dalfsen, J., van Hoey, G., Vincx, M., Willems, W., Rees, H.L., 2011. Changes in North Sea macrofauna communities and species distribution between 1986 and 2000. *Estuar. Coast. Shelf Sci.* 94, 1–15. doi:10.1016/j.ecss.2011.04.008

-
- Lang, A.C., Buschbaum, C., 2010. Facilitative effects of introduced Pacific oysters on native macroalgae are limited by a secondary invader, the seaweed *Sargassum muticum*. *J. Sea Res.* 63, 119–128. doi:10.1016/j.seares.2009.11.002
- Larkin, G.A., Slaney, P.A., 1997. Implications of trends in marine-derived nutrient influx to south coastal British Columbia salmonid production. *Fish. Res.* 22, 16–24.
- Leguerrier, D., Niquil, N., Petiau, A., Bodoy, A., 2004. Modeling the impact of oyster culture on a mudflat food web in Marennes-Oléron Bay (France). *Mar. Ecol. Prog. Ser.* 273, 147–162. doi:10.3354/meps273147
- Leontief, W., 1936. Quantitative Input and Output relations in the economic system of the United States. *Rev. Econ. Stat.* 18, 105–125.
- Libralato, S., Christensen, V., Pauly, D., 2006. A method for identifying keystone species in food web models. *Ecol. Modell.* 195, 153–171. doi:10.1016/j.ecolmodel.2005.11.029
- Likens, G.E., 1992. Excellence in ecology. Ecology Institute, Oldendorf.
- Lindeboom, H., Raaphorst, W., Beukema, J., Cadée, G., Swennen, C., 1995. Sudden changes in the North Sea and Wadden Sea: oceanic influences underestimated? *Dtsch. Hydrogr. Zeitschrift* 86–100.
- Lotze, H.K., Lenihan, H.S., Bourque, B.J., Bradbury, R.H., Cooke, R.G., Kay, M.C., Kidwell, S.M., Kirby, M.X., Peterson, C.H., Jackson, J.B.C., 2006. Depletion, degradation, and recovery potential of estuaries and coastal seas. *Science* (80-). 312, 1806–1809. doi:10.1126/science.1128035
- Lotze, H.K., Reise, K., Worm, B., Beusekom, van J.E.E., Busch, M., Ehlers, A., Heinrich, D., Hoffmann, R.C., Holm, P., Jensen, C., Knottnerus, O.S., Langhanki, N., Prummel, W., Vollmer, M., Wolff, W.J., 2005. Human transformations of the Wadden Sea ecosystem through time: a synthesis. *Helgol. Mar. Res.* 59, 84–95. doi:10.1007/s10152-004-0209-z
- Mace, P., 2004. In defense of fisheries scientists, single-species models and other scapegoats: confronting the real problems. *Mar. Ecol. Prog. Ser.* 274, 285–291.
- Markert, A., Wehrmann, A., Kröncke, I., 2009. Recently established *Crassostrea*-reefs versus native *Mytilus*-beds: differences in ecosystem engineering affects the macrofaunal communities (Wadden Sea of Lower Saxony, southern German Bight). *Biol. Invasions* 12, 15–32. doi:10.1007/s10530-009-9425-4
- Montgomery, D.R., Buffington, J.M., Peterson, N.P., Schuett-Hames, D., Quinn, T.P., 1996. Stream-bed scour, egg burial depths, and the influence of salmonid spawning on bed surface mobility and embryo survival. *Can. J. Fish. Aquat. Sci.* 53, 1061–1070. doi:10.1139/f96-028
- Myers, R.A., Worm, B., 2005. Extinction, survival or recovery of large predatory fishes. *Philos. Trans. R. Soc. Lond. B. Biol. Sci.* 360, 13–20. doi:10.1098/rstb.2004.1573

-
- Naylor, R., Hindar, K., Fleming, I., Goldburg, R., Williams, S., Volpe, J., Whoriskey, F., Eagle, J., Kelso, D., Mangel, M., 2005. Fugitive Salmon: assessing the risks of escaped fish from Net-Pen Aquaculture. *Bioscience* 55, 427. doi:10.1641/0006-3568(2005)055[0427:FSATRO]2.0.CO;2
- Nehls, G., Büttger, H., 2007. Spread of the Pacific oyster *Crassostrea gigas* in the Wadden Sea. The Common Wadden Sea Secretariat, Wilhelmshaven.
- Nehring, S., Reise, K., Dankers, N., Kristensen, P.S., 2009. Alien species thematic report No. 7, in: Marencic, H., Vlas de, J. (Eds.), Quality Status Report 2009. Wadden Sea Ecosystem No. 25. Common Wadden Sea Secretariat, Trilateral Monitoring and Assessment Group, Wilhelmshaven, Germany. p. 28.
- Norton, T.A., 1977. The growth and development of *Sargassum muticum* (Yendo) Fensholt. *J. Exp. Mar. Bio. Ecol.* 26, 41–53.
- Nye, J.A., Baker, M.R., Bell, R., Kenny, A., Kilbourne, K.H., Friedland, K.D., Martino, E., Stachura, M.M., van Houtan, K.S., Wood, R., 2013. Ecosystem effects of the Atlantic Multidecadal Oscillation. *J. Mar. Syst.* dx.doi.org, 103–116. doi:10.1016/j.jmarsys.2013.02.006
- Nyitrai, D., Martinho, F., Dolbeth, M., Rito, J., Pardal, M.A., 2013. Effects of local and large-scale climate patterns on estuarine resident fishes: The example of *Pomatoschistus microps* and *Pomatoschistus minutus*. *Estuar. Coast. Shelf Sci.* 135, 260–268. doi:10.1016/j.ecss.2013.10.030
- Odum, E.P., Barrett, G.W., 1971. *Fundamentals of ecology*.
- Ottersen, G., Planque, B., Belgrano, A., Post, E., Reid, P., Stenseth, N., 2001. Ecological effects of the North Atlantic Oscillation. *Oecologia* 128, 1–14. doi:10.1007/s004420100655
- Paine, R., 1969. A note on trophic complexity and community stability. *Am. Nat.* 103, 91–93.
- Patten, B., Bosserman, R., Finn, J., Cale, W., 1976. Propagation of cause in ecosystems, in: Patten, B. (Ed.), *Systems analysis and simulation in ecology*, Vol. IV. Academic Press, New York, pp. 457–579.
- Pauly, D., Christensen, V., Guénette, S., Pitcher, T.J., Sumaila, U.R., Walters, C.J., Watson, R., Zeller, D., 2002. Towards sustainability in world fisheries. *Nature* 418, 689–695.
- Perry, A.L., Low, P.J., Ellis, J.R., Reynolds, J.D., 2005. Climate change and distribution shifts in marine fishes. *Science* (80-). 308, 1912. doi:10.1126/science.1111322
- Peters, M., 2004. *Der Japanische Beerentang im Sylter Wattenmeer*. Univ. Göttingen. University of Göttingen.
- Polovina, J., 1984. Model of a coral reef ecosystem. I. The ECOPATH model and its application to French Frigate Shoals. *Coral Reefs* 3, 1–11.

-
- Polte, P., Asmus, H., 2006. Intertidal seagrass beds (*Zostera noltii*) as spawning grounds for transient fishes in the Wadden Sea. *Mar. Ecol. Prog. Ser.* 312, 235–243. doi:10.3354/meps312235
- Polte, P., Buschbaum, C., 2008. Native pipefish *Entelurus aequoreus* are promoted by the introduced seaweed *Sargassum muticum* in the northern Wadden Sea, North Sea. *Aquat. Biol.* 3, 11–18. doi:10.3354/ab00071
- Pörtner, H., Berdal, B., Blust, R., Brix, O., Colosimo, A., De Wachter, B., Giuliani, A., Johansen, T., Fischer, T., Knust, R., Lannig, G., Nævdal, G., Nedenes, A., Nyhammer, G., Sartoris, F.J., Serendero, I., Sirabella, P., Thorkildsen, S., Zakhartsev, M., 2001. Climate induced temperature effects on growth performance, fecundity and recruitment in marine fish: developing a hypothesis for cause and effect relationships in Atlantic cod (*Gadus morhua*) and common eelpout (*Zoarces viviparus*). *Cont. Shelf Res.* 21, 1975–1997.
- Powell, G.V.N., Fourqurea, J.W., Zieman, J.C., 1991. Bird colonies cause seagrass enrichment in a subtropical estuary: observational and experimental evidence. *Estuar. Coast. Shelf Sci.* 32, 567–579.
- Power, E., Tilman, D., Estes, J., Menge, B., Bond, W., Mills, L., Daily, G., Castilla, J., Lubchenco, J., Paine, R., 1996. Challenges in the quest for keystones. *Biol. Sci.* 46, 607–620.
- Reid, P.C., Fatima, M. De, Svendsen, E., 2001. A regime shift in the North Sea circa 1988 linked to changes in the North Sea horse mackerel fishery. *Fish. Res.* 50, 163–171.
- Reise, K., 1998. Pacific oysters invade mussel beds in the European Wadden Sea. *Senckenbergiana maritima* 28, 167–175. doi:10.1007/BF03043147
- Reise, K., 2005. Coast of change: habitat loss and transformations in the Wadden Sea. *Helgol. Mar. Res.* 59, 9–21. doi:10.1007/s10152-004-0202-6
- Rogers, J.C., 1984. The association between the North Atlantic Oscillation and the Southern Oscillation in the Northern Hemisphere. *Mon. Weather Rev.* 112, 1999–2015.
- Ruesink, J.L., Lenihan, H.S., Trimble, A.C., Heiman, K.W., Micheli, F., Byers, J.E., Kay, M.C., 2005. Introduction of Non-Native oysters: Ecosystem effects and restoration implications. *Annu. Rev. Ecol. Evol. Syst.* 36, 643–689. doi:10.1146/annurev.ecolsys.36.102003.152638
- Scheffer, M., Carpenter, S., Foley, J.A., Folke, C., Walker, B., 2001. Catastrophic shifts in ecosystems. *Nature* 413, 591–596. doi:10.1038/35098000
- Scheffer, M., Carpenter, S., Young, de B., 2005. Something old, something transgenic, or something fungal for mosquito control? *Trends Ecol. Evol.* 20, 579–581. doi:10.1016/j.tree.2005.08.007
- Schumpeter, J.A., 1978. History of economic analysis. for the future, in: Schumpeter, E.B. (Ed.), Oxford University Press, New York, p. 1231.

-
- Shannon, C.E., 1948. A Mathematical theory of communication. *Bell Syst. Tech. J.* 27, 379–423.
- Sims, D.W., Mouth, V.J.W., Genner, M.J., Southward, A.J., Hawkins, S.J., 2004. Low-temperature-driven early spawning migration of a temperate marine fish. *J. Anim. Ecol.* 73, 333–341.
- Springer, A.M., Estes, J.A., van Vliet, G.B., Williams, T.M., Doak, D.F., Danner, E.M., Forney, K.A., Pfister, B., 2003. Sequential megafaunal collapse in the North Pacific Ocean: an ongoing legacy of industrial whaling? *Proc. Natl. Acad. Sci. U. S. A.* 100, 12223–12228. doi:10.1073/pnas.1635156100
- Stæhr, P.A., Pedersen, M.F., Thomsen, M.S., Wernberg, T., Krause-Jensen, D., 2000. Invasion of *Sargassum muticum* in Limfjorden (Denmark) and its possible impact on the indigenous macroalgal community. *Mar. Ecol. Prog. Ser.* 207, 79–88.
- Tansley, A., 1935. The use and abuse of vegetational concepts and terms. *Ecology* 16, 284–307.
- Tulp, I., Bolle, L.J., Rijnsdorp, A.D., 2008. Signals from the shallows: In search of common patterns in long-term trends in Dutch estuarine and coastal fish. *J. Sea Res.* 60, 54–73. doi:10.1016/j.seares.2008.04.004
- Ulanowicz, R., 1986. Theoretical ecology: Ecosystem ascendancy, in: 1987 yearbook of science and technology. McGraw-Hill, New York, pp. 481–483.
- Ulanowicz, R.E., 2004. Quantitative methods for ecological network analysis. *Comput. Biol. Chem.* 28, 321–39. doi:10.1016/j.compbiolchem.2004.09.001
- Ulanowicz, R.E., Kay, J.J., 1991. A package for the analysis of ecosystem flow networks. *Environ. Softw.* 6, 131–142.
- Ulanowicz, R.E., Puccia, C., 1990. Mixed trophic impacts in ecosystems. *Coenoses* 5, 7–16.
- Viejo, R.M., 1999. Mobile epifauna inhabiting the invasive *Sargassum muticum* and two local seaweeds in northern Spain. *Aquat. Bot.* 64, 131–149. doi:10.1016/S0304-3770(99)00011-X
- Vitousek, P.M., 1990. Biological invasions and ecosystem processes: towards an integration of population biology and ecosystem studies. *Oikos* 57, 7–13.
- Vitousek, P.M., Mooney, H., Lubchenco, J., Melillo, J., 1997. Human domination of earth's ecosystems. *Science* (80-.). 277, 494–499. doi:10.1126/science.277.5325.494
- Vitousek, P.M., Aber, J.D., Howarth, R.W., Likens, G.E., Matson, P.A., Schindler, D.W., Schlesinger, W.H., Tilman, D.G., 1997a. Human alteration of the global nitrogen cycle: sources and consequences. *Ecol. Appl.* 7, 737–750. doi:10.1890/1051-0761(1997)007[0737:HAOTGN]2.0.CO;2

-
- Vitousek, P.M., D'Antonio, C.M., Loope, L.L., Rejmanek, M., Westbrooks, R., 1997b. Introduced species: a significant component of human-caused global change. *New Zeel. J. Ecol.* 21, 1–16.
- Volkenborn, N., Hedtkamp, S.I.C., Beusekom, van J.E.E., Reise, K., 2007. Effects of bioturbation and bioirrigation by lugworms (*Arenicola marina*) on physical and chemical sediment properties and implications for intertidal habitat succession. *Estuar. Coast. Shelf Sci.* 74, 331–343. doi:10.1016/j.ecss.2007.05.001
- Walker, G.T., Bliss, E.W., 1932. World weather. V. *Mem. Roy. Meteor. Soc.* 4, 53–84.
- Walther, G.-R., Roques, A., Hulme, P.E., Sykes, M.T., Pysek, P., Kühn, I., Zobel, M., Bacher, S., Botta-Dukát, Z., Bugmann, H., Czúcz, B., Dauber, J., Hickler, T., Jarosík, V., Kenis, M., Klotz, S., Minchin, D., Moora, M., Nentwig, W., Ott, J., Panov, V.E., Reineking, B., Robinet, C., Semchenko, V., Solarz, W., Thuiller, W., Vilà, M., Vohland, K., Settele, J., 2009. Alien species in a warmer world: risks and opportunities. *Trends Ecol. Evol.* 24, 686–93. doi:10.1016/j.tree.2009.06.008
- Weijerman, M., Lindeboom, H., Zuur, A.F., 2005. Regime shifts in marine ecosystems of the North Sea and Wadden Sea. *Mar. Ecol. Prog. Ser.* 298, 21–39.
- Whitfield, K., Elliott, M., 2002. Fishes as indicators of environmental and ecological changes within estuaries: a review of progress and some suggestions for the future. *J. Fish Biol.* 61, 229–250. doi:10.1006/jfbi.2002.2079
- Wilkinson, C.R., 2004. Status of coral reefs of the World 2004: Summary. Australian Institute of Marine Science Townsville.
- Wiltshire, K.H., Manly, B.F.J., 2004. The warming trend at Helgoland Roads, North Sea: phytoplankton response. *Helgol. Mar. Res.* 58, 269–273. doi:10.1007/s10152-004-0196-0
- Worm, B., Barbier, E.B., Beaumont, N., Duffy, J.E., Folke, C., Halpern, B.S., Jackson, J.B.C., Lotze, H.K., Micheli, F., Palumbi, S.R., Sala, E., Selkoe, K. a, Stachowicz, J.J., Watson, R., 2006. Impacts of biodiversity loss on ocean ecosystem services. *Science* 314, 787–90. doi:10.1126/science.1132294
- Wulf, F., Ulanowicz, R., 1989. A comparative anatomy of the Baltic Sea and Chesapeake Bay ecosystems, in: Wulf, F., Field, J., Mann, K. (Eds.), *Network Analysis in Marine Ecology Coastal and Estuarine Studies Series*. Springer-Verlag, Berlin, pp. 232–256.
- Wunderle J.M.Jr, Wiley, J.W., 1996. Effects of hurricanes on wildlife: implications and strategies for management, in: *Conservation of Faunal Diversity in Forested Landscapes*. Springer, pp. 253–264.
- Young de, B., Harris, R., Alheit, J., Beaugrand, G., Mantua, N., Shannon, L., 2004. Detecting regime shifts in the ocean: data considerations. *Prog. Oceanogr.* 60, 143–164. doi:10.1016/j.pocean.2004.02.017

THESIS OUTLINE

This thesis investigates the interrelation of fish species with the abiotic and biotic parameters in a changing environment in order to detect possible trends in fish communities of the northern Wadden Sea.

The first step is to observe the influence of abiotic ecosystem characteristics and the effect of new habitats formed by introduced bioengineers on the fish species composition, abundance and trophic interactions. In a second step the other side of the coin is investigated, namely possible impacts of fish on ecosystem processes, such as energy transport, direct and indirect relationships and the effect of an abundant species on the food web.

In the following four chapters, the results on the study of a coastal, boreal fish community of the Wadden Sea are presented. The subsequent abstracts present the thoughts, motivation and the background of the investigation.

Outline Chapter I

THE FISH COMMUNITY IN THE NORTHERN WADDEN SEA RELATED TO ABIOTIC FACTORS AND LARGE SCALE CLIMATE OSCILLATIONS

Moritz Pockberger, Florian Kellnreitner, Ragnhild Asmus, Birgit Hussel, Petra Kadel, Harald Asmus

Manuscript in preparation (Journal of Sea Research)

Rising temperatures are described for the Wadden Sea and North Sea (e.g. Wiltshire and Manly, 2004; Martens and Beusekom, 2008). Based on changing abiotic factors, Westernhagen (1993) predicted the immigration of thermophile and the emigration of cryophilic fish species. Long term observations (e.g. Tulp et al., 2008; Veer et al., 2011) show changes in species composition and biomass in Wadden Sea and North Sea. Following the

prediction of Westernhagen (1993) and the results of other previous investigations, the fish community in a northern Wadden Sea area, the Sylt-Rømø bight was investigated (Chapter I). To detect abundance and migration patterns, fish were surveyed monthly over a period of 5 years. Since abiotic habitat characteristics are driving forces causing fish migration, abundance data was related to temperature and salinity. Water depth was also considered in order to find out if shallow coastal waters are preferred, compared to the open North Sea. Temperature and salinity are influenced by large scale climate oscillations, such as the North Atlantic Oscillation (NAO), Martens (2001) described the correlation between NAO and abiotic factors in the Sylt-Rømø bight. The impact of NAO on fish communities is observed for different areas in Europe (e.g. Nyitrai et al., 2013), but it is still under investigation for Wadden Sea areas.

Outline Chapter II

AN ABUNDANT SMALL SIZED FISH AS KEYSTONE SPECIES? THE EFFECT OF *POMATOSCHITUS MICRIPS* ON FOOD WEBS AND ITS TROPHIC ROLE IN TWO INTERTIDAL BENTHIC COMMUNITIES: A MODELING APPROACH

Moritz Pockberger, Florian Kellnreitner, Harald Ahnelt, Ragnhild Asmus, Harald Asmus

Journal of Sea Research, 86, 86-96 (2014)

The first ENA for the Sylt-Rømø bight were presented by Baird et al. (2004, 2007). In these publications direct and indirect trophic relationships in the whole bight and of different intertidal habitats were presented. The motivation for the research described in Chapter II were network calculations for the Sylt-Rømø bight, publications on the importance of fish for upper and lower trophic levels (e.g. Zander and Hartwig, 1982; Kubetzki and Garthe, 2003), and further the conclusions of Coll and Libralato (2012). These authors state that fish of mean trophic position may control energy flows when they are dominant components on

that particular trophic level. Based on this statement the following question emerged: How strong do abundant fish species of medium trophic position impact the energy transport between lower and upper trophic levels in the Wadden Sea?

Pomatoschistus microps, the common goby, was chosen as target species since it is very abundant and it is positioned on a mean trophic level, feeding on higher and lower trophic levels. The investigation reveals direct and indirect trophic interactions in the Wadden Sea. Information on the function and importance of small seized fish for the energy transport is given.

Outline Chapter III

INVESTIGATION OF FISH SPECIES OCCURRENCE AND COMPOSITION INTRODUCED ALGAL FORESTS (*SARGASSUM MUTICUM*): PROVIDING A NEW HABITAT FOR NATIVE FISH?

Moritz Pockberger, Florian Kellnreitner, Ragnhild Asmus, Harald Asmus

Manuscript in preparation (Marine Ecology Progress Series)

Plants in inter- and subtidal areas of the Wadden Sea form important habitats as spawning and nursery grounds for fish species (Polte and Asmus, 2006a, 2006b; Polte et al., 2005). Wolff (2000) concludes that the loss of subtidal seagrass meadows of *Zostera marina*, caused a loss of structural complexity and biodiversity. The invasive algae *Sargassum muticum* forms dense forests in the shallow subtidal of the Sylt-Rømø bight, which may act as a substitute for lost seagrass meadows (Polte and Buschbaum, 2008). Fish depending on subtidal plant canopies, such as *Entelurus aequoreus* (snake pipefish) were abundant in the algal forest (Polte and Buschbaum, 2008). Subsequently the hypothesis of a possible recolonisation by an almost lost and very rare fish species was presented by Polte and Buschbaum (2008). In order to investigate whether *S. muticum* forests comprise a new

habitat for fish species as well as describe the fish community of a *Sargassum* forest the survey presented in Chapter III was conducted. This habitat could not be enclosed in the survey presented in Chapter I, because special sampling methods had to be used. The comparison of the fish abundance in the *Sargassum* forest to adjacent areas might help to understand the influence of new habitats on certain fish species.

Outline Chapter IV

INTERNAL PROCESSES OF A HABITAT FORMING SPECIES: WHAT IS HIDDEN BEHIND DENSE FORESTS OF *SARGASSUM MUTICUM*?

Moritz Pockberger, Florian Kellnreitner, Niels Reinecke, Ragnhild Asmus, Harald Asmus

Manuscript in preparation (Food Webs)

Ecological network analysis (ENA) presents a useful tool to investigate the food web and energy transport of ecosystems (Ulanowicz, 2004). Baird et al. (2012) studied the influence of introduced species on the energy transport in the Sylt-Rømø bight. The authors concluded that a sudden decline or loss of the new species, e.g. by a cold winter, causes decreasing energy flows followed by a possible destabilisation of the ecosystem. The introduced species *Caprella mutica* is abundant in *Sargassum muticum* forests (Buschbaum and Reise, 2010) and was found in guts of fish (Chapter IV). In order to investigate the importance of the prey taxa, e.g. *C. mutica*, as energy resource the analyses in Chapter IV were made. Furthermore, the food web and energy transports in the new habitat were analysed, while the characteristics of these trophic networks and possible effects on nearby habitats are discussed.

References Thesis Outline

- Attrill, M.J., Power, M., 2002. Climatic influence on a marine fish assemblage. *Nature* 417, 275–278. doi:10.1038/417275a
- Baird, D., Asmus, H., Asmus, R., 2004. Energy flow of a boreal intertidal ecosystem, the Sylt-Rømø bight. *Mar. Ecol. Prog. Ser.* 279, 45–61. doi:10.3354/meps279045
- Baird, D., Asmus, H., Asmus, R., 2007. Trophic dynamics of eight intertidal communities of the Sylt-Rømø bight ecosystem, northern Wadden Sea. *Mar. Ecol. Prog. Ser.* 351, 25–41. doi:10.3354/meps07137
- Baird, D., Asmus, H., Asmus, R., 2012. Effect of invasive species on the structure and function of the Sylt-Rømø bight ecosystem, northern Wadden Sea, over three time periods. *Mar. Ecol. Prog. Ser.* 462, 143–161. doi:10.3354/meps09837
- Behrends, G., 1985. Zur Nahrungswahl von Seehunden (*Phoca vitulina* L.) im Wattenmeer Schleswig-Holsteins. *Zeitschrift für Jagdwissenschaften* 31, 3–14.
- Buschbaum, C., Reise, K., 2010. Neues Leben im Weltnaturerbe Wattenmeer. Globalisierung unter Wasser. *Biol. unserer Zeit* 40, 202–210. doi:10.1002/biuz.201010424
- Coll, M., Libralato, S., 2012. Contributions of food web modelling to the ecosystem approach to marine resource management in the Mediterranean Sea. *Fish Fish.* 13, 60–88. doi:10.1111/j.1467-2979.2011.00420.x
- Henderson, P.A., 2007. Discrete and continuous change in the fish community of the Bristol channel in response to climate change. *J. Mar. Biol. Assoc. UK* 87, 589–598. doi:10.1017/S0025315407052447
- Kubetzki, U., Garthe, S., 2003. Distribution, diet and habitat selection by four sympatrically breeding gull species in the south-eastern North Sea. *Mar. Biol.* 143, 199–207. doi:10.1007/s00227-003-1036-5
- Martens, P., 2001. Effects of the severe winter 1995/96 on the biological oceanography of the Sylt-Rømø tidal basin. *Helgol. Mar. Res.* 55, 166–169. doi:10.1007/s101520100078
- Martens, P., Beusekom, van J.E.E., 2008. Zooplankton response to a warmer northern Wadden Sea. *Helgol. Mar. Res.* 62, 67–75. doi:10.1007/s10152-007-0097-0
- Nyitrai, D., Martinho, F., Dolbeth, M., Rito, J., Pardal, M.A., 2013. Effects of local and large-scale climate patterns on estuarine resident fishes: the example of *Pomatoschistus microps* and *Pomatoschistus minutus*. *Estuar. Coast. Shelf Sci.* 135, 260–268. doi:10.1016/j.ecss.2013.10.030
- Pihl, L., Rosenberg, R., 1982. Production, abundance and biomass of mobile epibenthic marine fauna in shallow waters, western Sweden. *J. Exp. Mar. Biol. Ecol.* 51, 273–301.

-
- Polte, P., Asmus, H., 2006a. Influence of seagrass beds (*Zostera noltii*) on the species composition of juvenile fishes temporarily visiting the intertidal zone of the Wadden Sea. *J. Sea Res.* 55, 244–252. doi:10.1016/j.seares.2005.11.004
- Polte, P., Asmus, H., 2006b. Intertidal seagrass beds (*Zostera noltii*) as spawning grounds for transient fishes in the Wadden Sea. *Mar. Ecol. Prog. Ser.* 312, 235–243. doi:10.3354/meps312235
- Polte, P., Buschbaum, C., 2008. Native pipefish *Entelurus aequoreus* are promoted by the introduced seaweed *Sargassum muticum* in the northern Wadden Sea, North Sea. *Aquat. Biol.* 3, 11–18. doi:10.3354/ab00071
- Polte, P., Schanz, A., Asmus, H., 2005. The contribution of seagrass beds (*Zostera noltii*) to the function of tidal flats as a juvenile habitat for dominant, mobile epibenthos in the Wadden Sea. *Mar. Biol.* 147, 813–822. doi:10.1007/s00227-005-1583-z
- Tulp, I., Bolle, L.J., Rijnsdorp, A.D., 2008. Signals from the shallows: in search of common patterns in long-term trends in Dutch estuarine and coastal fish. *J. Sea Res.* 60, 54–73. doi:10.1016/j.seares.2008.04.004
- Ulanowicz, R.E., 2004. Quantitative methods for ecological network analysis. *Comput. Biol. Chem.* 28, 321–39. doi:10.1016/j.compbiolchem.2004.09.001
- Veer, van der H., Koot, J., Aarts, G., Dekker, R., Diderich, W., Freitas, V., Witte, J., 2011. Long-term trends in juvenile flatfish indicate a dramatic reduction in nursery function of the Balgzand intertidal, Dutch Wadden Sea. *Mar. Ecol. Prog. Ser.* 434, 143–154. doi:10.3354/meps09209
- Westernhagen von, H., 1993. Mögliche klimabedingte Beeinflussung der Nordsee-Ichthyofauna, in: Schellnhuber, H.J., Sterr, H. (Eds.), *Klimaänderung und Küste*. Springer, Berlin, Heidelberg, pp. 212–222.
- Wiltshire, K.H., Manly, B.F.J., 2004. The warming trend at Helgoland Roads, North Sea: phytoplankton response. *Helgol. Mar. Res.* 58, 269–273. doi:10.1007/s10152-004-0196-0
- Wolff, W.J., 2000. The south-eastern North Sea: losses of vertebrate fauna during the past 2000 years. *Biol. Conserv.* 95.
- Zander, D., Hartwig, E., 1982. On the biology of small-seized fish from North and Baltic Sea areas. IV. Investigations on an eulittoral mud flat at Sylt island. *Helgol. Mar. Res.* 35, 47–63.

CHAPTER I. THE FISH COMMUNITY IN THE NORTHERN WADDEN SEA RELATED TO ABIOTIC FACTORS AND LARGE SCALE CLIMATE OSCILLATIONS

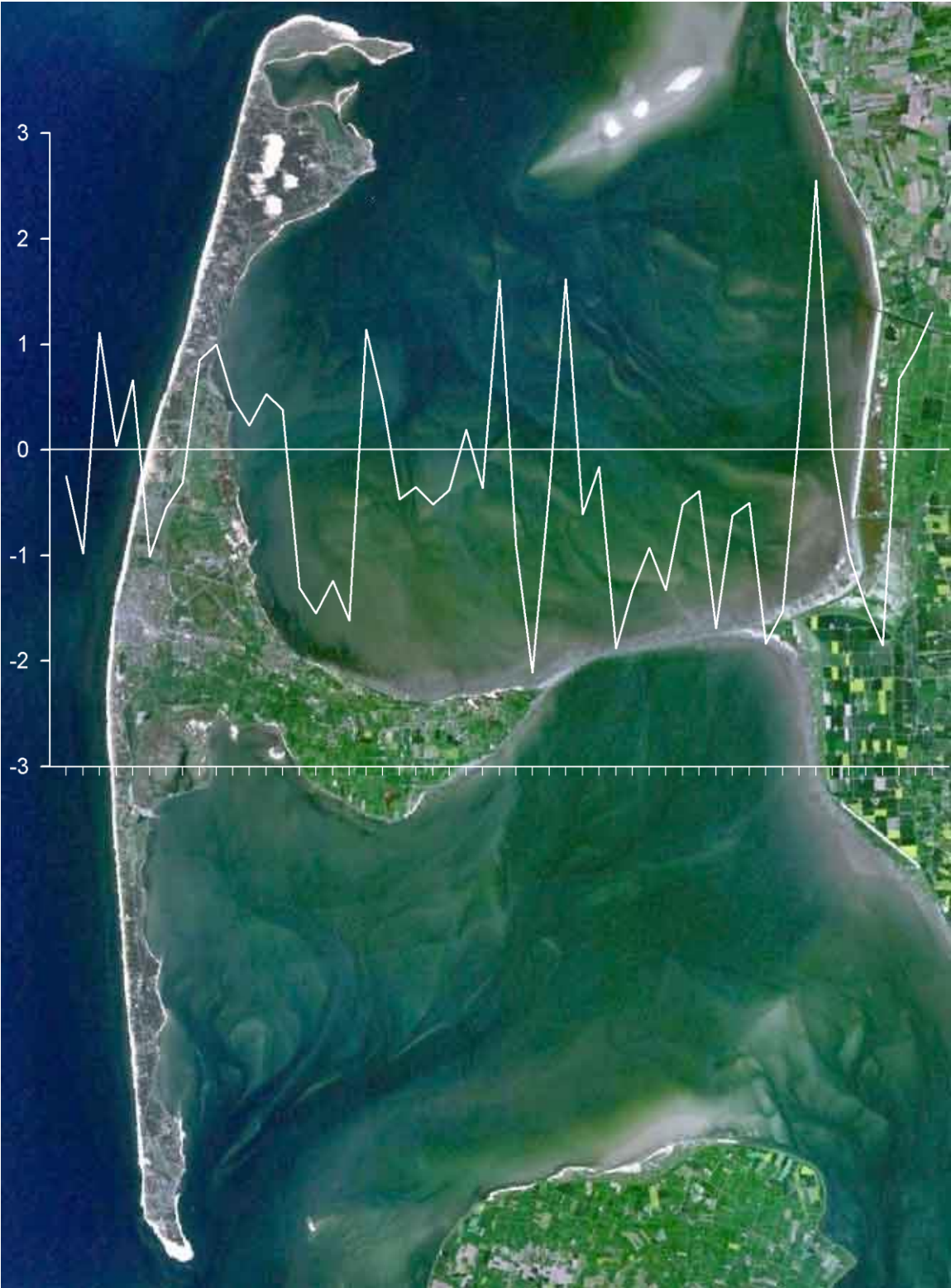

Picture p. 41 The island Sylt and the diagram of the North Atlantic Oscillation;
Sources: <http://www.noaa.gov/>; <http://commons.wikimedia.org/wiki/File:SyltSat.jpg>

CHAPTER I. THE FISH COMMUNITY IN THE NORTHERN WADDEN SEA RELATED TO ABIOTIC FACTORS AND LARGE SCALE CLIMATE OSCILLATIONS

Moritz Pockberger*, Florian Kellnreitner, Ragnhild Asmus, Birgit Husel, Petra Kadel, Harald Asmus

Alfred-Wegener-Institute, Helmholtz-Zentrum für Polar- und Meeresforschung, Wadden Sea Station Sylt, Hafenstrasse 43, D-25992 List, Germany

* corresponding author: moritz.pockberger@awi.de

Abstract

The Wadden Sea provides important habitats for abundant and threatened fish species. Besides the dynamic characteristics of the Wadden Sea, abiotic parameters are changed due to climate alterations affecting fish communities. Here monthly data of a 5 year monitoring are presented, investigating the impact of abiotic parameters and atmospheric oscillations on species of 4 different biogeographic guilds (Atlantic, boreal-arctic, boreal, lusitanian) and 3 vertical habitats (benthopelagic, demersal, pelagic). Fish abundance was correlated to mean sea surface temperature (SST) and monthly indices of the North Atlantic Oscillation (NAO). In total 47 fish species were sampled. Results indicate changed species composition in the investigated area, as 3 boreal and 4 lusitanian species, observed in previous investigations, were not found in the present survey. Instead 2 boreal-arctic (*Liparis montagui*, *Pungitius pungitius*), 2 lusitanian (*Alosa alosa*, *Pomatoschistus lozanoi*) and 1 Pacific species (*Oncorhynchus mykiss*) were found additionally. Statistical calculations show significant positive correlations between increased temperature and abundance of boreal-benthopelagic and lusitanian-demersal species. Significant negative correlations were calculated for boreal-arctic-demersal and boreal-demersal species. The impact of NAO could be related to peak abundances, investigating a time lag up to 11 months. Monthly samplings give a detailed picture of fish abundance and species composition in the sampled area. The

absence of 4 lusitanian species, at least during the investigated observation period, does not support the assumption of increasing proportions of thermophile species in the fish community. A correlation between NAO values and maximum abundance, the biogeographic guild as well as the vertical habitat affiliation gave significant results, however depended on time-lags that differ strongly within the particular groups. Therefore we show that in the selected time period local environmental factors such as SST have had a stronger impact on a dynamic coastal fish community compared to the large scale climate scenario.

Key words

fish community, lusitanian species, near coast habitat, large scale climate oscillation, Wadden Sea, North Atlantic Oscillation

1. Introduction

The importance of Wadden Sea areas for fish species as spawning, nursery and feeding grounds is well investigated (Beukema, 1992; Polte et al., 2005; Tulp et al., 2008; Zijlstra, 1972). In the Wadden Sea, fish communities are permanently exposed to changing conditions, due to the dynamic characteristics of this system (Herrmann et al., 1998). Besides the dynamic characteristics, abiotic parameters change due to large-scale climate alterations (Tulp et al., 2008). Martens and Beusekom (2008) described increasing temperatures and a prolongation of seasonal warmer periods up to 1 month in northern Wadden Sea areas. Dippner (1997) discussed changing conditions affecting coastal waters in the North Sea and Harley et al. (2006) stated that coastal marine areas are endangered world-wide by changing atmospheric circulations influencing precipitation and the frequency of storms altering the salinity and turbidity of shallow waters exposed to external influences. Extended warmer periods and further changes in coastal ecosystems might favor the immigration of species, which in turn can cause new trophic interactions (Kellnreitner et al.,

2012). Increasing temperatures and changing abiotic factors can have major impacts on fish species, e.g. decreased growth rates and fecundity (Pörtner et al., 2001) and might alter the species composition. To avoid unfavorable high temperatures fish species characteristic for the Wadden Sea migrate northwards and more stationary species visit deeper water bodies of the North Sea (Dulvy et al., 2008; Perry et al., 2005). Hence deeper areas, where abiotic parameters are more stable, might provide important refugia for cryophilic species.

Another main characteristic influencing the suitability of a water body is salinity. Changes of salinity may not only affect fish directly, but can also influence phyto- and zooplankton at the base of the food web and therefore have an impact on higher trophic levels feeding on them (Edwards et al., 2002; Weijerman et al., 2005). The above mentioned abiotic parameters are influenced by major climate systems such as the North Atlantic Oscillation (NAO) (Ottersen et al., 2001).

Walker and Bliss (1932) hypothesised that changes of sea surface temperature (SST) and abiotic parameters are consequences of the NAO which they calculated from differences in the atmospheric pressure at sea level between Iceland and the Azores. The NAO is a main factor influencing the climate in the North Atlantic region and Western Europe (Rogers, 1984; Wallace and Gutzler, 1981). Positive NAO indicate stronger storms and warmer SST, while negative values characterise weaker winds and colder SST in winter and spring (Ottersen et al., 2001). Atmospheric impacts are mainly responsible for the temperature regime of the North Sea and NAO is one of the main factors influencing the variance of SST in the German bight (Dippner, 1997). Becker and Pauly (1996) identified a 5 to 10 years climate oscillation affecting North Sea areas. The effect of climate on the abundance of various fish species is well investigated (Alheit et al., 2012; Kerby et al., 2013; MacKenzie and Köster, 2004; Pörtner et al., 2001; Pörtner and Knust, 2007; Reid et al., 2001; Sims et al.,

2004). To date it is not clear if changes observed in the North Sea follow a certain pattern induced by climate, but it is widely agreed that such changes have happened in the past (Corten and Kamp, 1996; Corten, 1990; Daan et al., 1996; Dippner, 1997).

According to these observations Westernhagen (1993) expected a higher proportion of thermophile species in the Wadden Sea while boreal-arctic and boreal species move toward colder, arctic regions. Long-term observations of fish in the Wadden Sea show changing species composition and decreasing biomass (Tulp et al. 2008; Veer et al. 2011; Wolff, 2013). In the North Sea, Wadden Sea and transitional waters several long-term fish surveys and monitoring programs are ongoing, covering major parts of the Wadden Sea coast along Germany and the Netherlands (Jager et al., 2009; TMAP, 2006). Most surveys are conducted annually, seasonally or restricted to certain months (BSH, 2012). The Demersal Fish Survey (DFS), established in 1969 conducted in spring (1969 - 1987) and in fall (1969 - today), is the only sampling campaign which provides data for northern and Danish Wadden Sea areas (Vorberg et al., 2005). In the Quality Status Report (QSR) of 2009 additional surveys are recommended “expanding the spatial coverage, including Danish Wadden Sea areas” and “extended monitoring periods to consider seasonal patterns of species abundances” (Jager et al., 2009). In the following text we present a fish survey conducted monthly, since 2007, in a northern Wadden Sea area, close to the Danish boarder. The most recent scientific large-scale fish survey in this area was conducted from 1990 to 1994 in the frame of the ecosystem project “Sylter Wattenmeer Austauschprozesse” (SWAP) financed by the German Federal Ministry of Education and Research (BMBF). The here presented survey investigates the fish community in boreal coastal waters in the northern part of the Wadden Sea. For this reason a high temporal resolution of monthly samplings was conducted in the present study in order for a more detailed insight into the species composition and abundance of fish to be

acquired. Especially, it is expected that the dispersal and occurrence of thermophile, introduced, and characteristic Wadden Sea fish species will be better understood by analysing data of a much more frequent sampling.

The aim of the present investigation is to answer the following questions:

A. Species composition, abundance and dispersal

Are changes in species composition observable compared to previous investigations and are these changes possibly induced by extended warmer seasons?

Are thermophile species, e.g. lusitanian species, more numerous and abundant than cold water adapted species, e.g. boreal-arctic and boreal species?

How do fish of different biogeographic origin and vertical habitats disperse locally and seasonally in boreal coastal waters?

B. Correlation between abundance and local abiotic factors

Are species of different biogeographic origin and vertical habitats in the water column impacted differently by fluctuating salinity and temperature in the northern Wadden Sea?

How strong is the abundance of characteristic resident Wadden Sea species affected by temperature?

C. Impact of a climate large scale oscillation

Are peak abundances of fish species of different biogeographic origin and vertical habitats linked to large scale climate influences as NAO?

2. Materials & Methods

2.1. Study site

This study was conducted in the Sylt-Rømø bight (SRB) (54° 52' - 55° 10' N, 8° 20' - 8° 40' E), which is located between the islands of Sylt (Germany) and Rømø (Denmark) situated in the North Sea, German Bight. The SRB is part of the Wadden Sea, which extends along the coast of the south-eastern North Sea reaching from the Netherlands to Denmark (Fig. 1). The bight comprises an area of 404 km², including 135 km² of tidal flats (Asmus and Asmus, 2000) (Fig. 1). Two causeways connecting the islands with the mainland inhibit both, the movement of water around the islands and the direct exchange with adjacent tidal basins (Fig. 1). Between the islands there is only one tidal inlet of 2 km width and 40 m depth (Bayerl and Köster, 1998) (Fig. 1). The tidal range inside the bight is 2 m (Martens and Beusekom, 2008). Two rivers discharge into the bight, the Brede Å and the Vidå. A detailed description of the SRB is given in Gätje and Reise (1998).

2.2. Sampling of Fish

Sampling took place monthly at seven locations inside the SRB and its tidal inlet (Fig. 1). Complementary two locations, one situated centrally in the bight, close to the Danish border and one outside the bight, in the North Sea, were sampled every three months (Fig. 1). Station characteristics are given in Fig. 1. At each station one haul in the water column and another at the bottom were sampled for 15 minutes at a speed of approximately 2 knots. Fish were sampled using a 17 m long mini bottom trawl, which is designed to be deployed also as flyde trawl for pelagic fishing. The mouth of the net was up to 7 m in width and 3 m

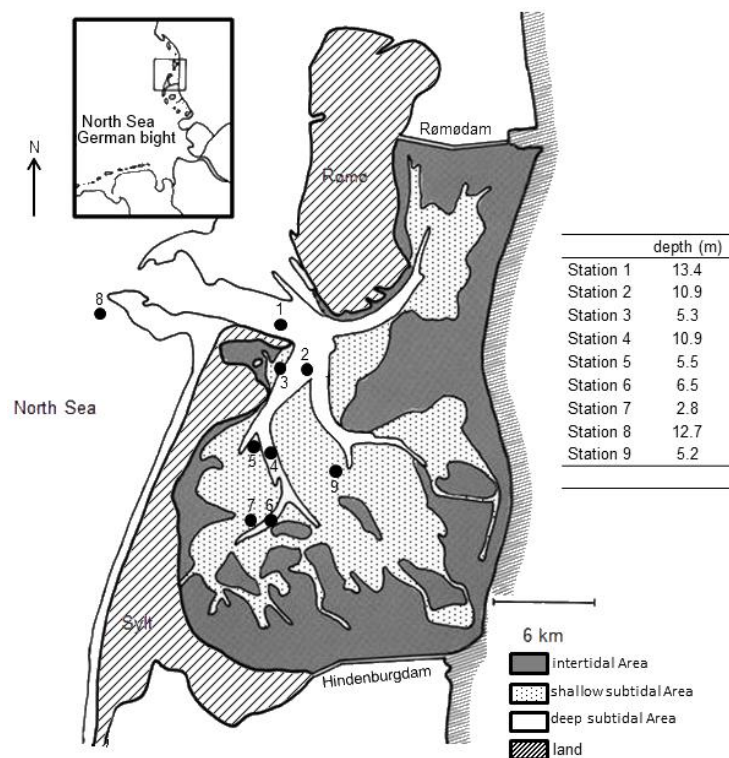

Fig. 1. Position of the islands Sylt and Rømø in the German Bight and the North Sea. Different habitats of the Sylt - Rømø bight: grey areas indicate intertidal flats; stippled areas indicate shallow subtidal, white areas indicate deep subtidal and striped areas indicate land. Black circles and numbers 1 to 9 show the position of sampling stations (redrawn after Asmus and Asmus (2000)). The water depth (m) of Station 1 to 9 is given.

in height. Mesh size measured 32 mm in the wings, 16 mm in the mid part and 6 mm in the cod end. Sampled fish were identified and subdivided according to species, counted and total length (TL) was measured to the closest 5 mm. If the sample size was large, the total of all individuals of an abundant species, present in the sample, was weighted and subsamples were weighted, counted and measured.

2.3. Sampling of abiotic parameters

Salinity, depth and SST (Fig. 2) were measured during sampling of fish at each station. As salinity measurements started in July 2008, missing data (January 2007 until June 2008) was complemented using data, sampled in the SRB, in the frame of the Ecological Time Series of

the AWI in the North Sea. Data of the monthly NAO index were obtained from ftp://ftp.cpc.ncep.noaa.gov/wd52dg/data/indices/nao_index.tim (accessed 17 August 2013).

2.4. Data analysis

To overview data of sampled species the mean abundance (individuals per 1000 m²) and standard deviation (SD) of fish were calculated for each year and each season using individual numbers sampled monthly from 2007 to 2011. To investigate the possible effects of abiotic factors on the fish community in the SRB, species were divided into nine groups combining their classification into biogeographic guilds (Atlantic, boreal, lusitanian) and their dependence on a certain vertical habitat (demersal, benthopelagic, pelagic) including every life stage from eggs to adults (Collie et al., 2008; Froese and Pauly, 2010; Tulp et al., 2008; Yang, 1982). These groups are 1) Atlantic-demersal, 2) Atlantic-pelagic, 3) boreal-arctic-benthopelagic, 4) boreal-arctic-demersal, 5) boreal-benthopelagic, 6) boreal-demersal, 7) lusitanian-demersal, 8) lusitanian-pelagic and 9) Pacific-benthopelagic. Epipelagic species were grouped as pelagic species. These groups are indicated as biogeographic-habitat groups in the text that follows. To get an idea how fish disperse at sampling stations and in different seasons the Shannon- (H') (Shannon, 1948) (Eq.1, 2), the Evenness- (J) (Pielou, 1966) (Eq.3, 4) and the Simpson index (D) (Simpson, 1949) (Eq. 5) were calculated in Primer 6 (Clarke and Gorley, 2006) using the mean abundance of species. For H' , which is sensitive towards the change of rare species, no upper limit exists and values range from 0 to infinite. High diversity is indicated by high numbers of H' (Solow, 1993). Values of J range from 0 to 1. Values close to 1 indicate equability of species abundance (Peet, 1974).

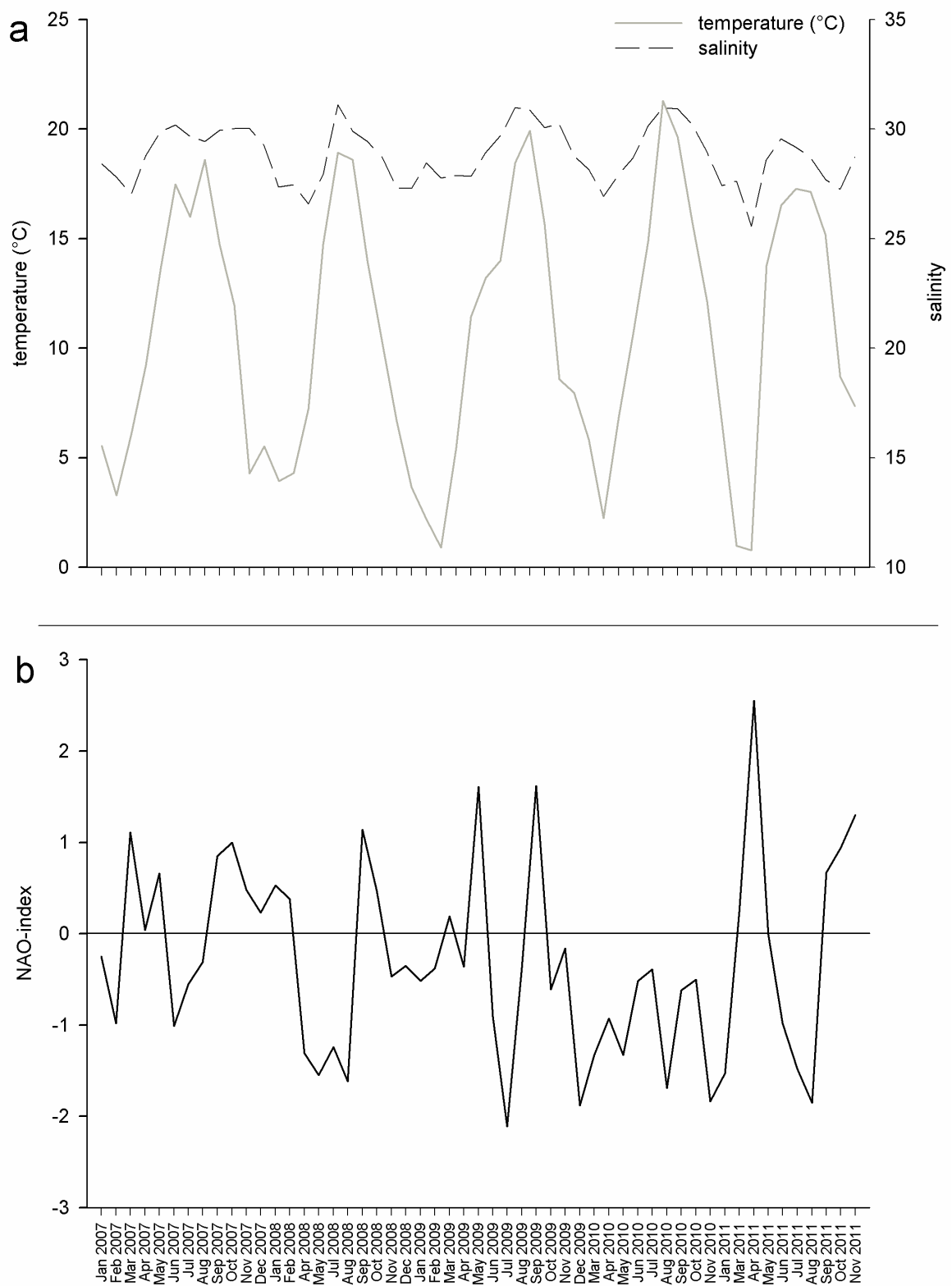

Fig. 2a. Sea surface temperature (°C) and salinity measured during sampling.

Fig 2b. Indices of the North Atlantic Oscillation (NAO) during sampling time.

The second index of diversity (D) was calculated, due to index sensitivity towards common species, values range from 0 to 1, where 0 indicates infinite or high Diversity (Peet, 1974). As this seems confusing, the Simpson index of Diversity (1 - D) is suggested, higher values indicate higher Diversity (Peet, 1974).

$$H' = \sum_i p_i * \log p_i \quad (\text{Eq.1})$$

H' = Shannon index, p_i = the sum of the proportion of species i over all species.

$$p_i = n_i * N^{-1} \quad (\text{Eq.2})$$

p_i = the sum of the proportion of species i over all species, n_i = individual number of species i

N = the total number of individuals of all species.

$$J = H' * H_{\max}^{-1} \quad (\text{Eq.3})$$

J = Evenness index, H' = Shannon index, H_{\max} = maximum value of H'

$$H_{\max} = -\log(1 * i^{-1}) \quad (\text{Eq.4})$$

H_{\max} = maximum value of H', i = number of species.

$$D = \sum(n_i * N^{-1})^2 \quad (\text{Eq.5})$$

D = Simpson index, n_i = the total number of individuals of species i, N = the total number of individuals of all species.

Data were tested for normal distribution employing the Shapiro-Wilk test. Each biogeographic-habitat group was correlated with SST, salinity and depth. The correlation between fish abundance and SST was calculated in steps of 1 °C. In a second step a robust regression model was calculated, number of bootstrap samples 2000, using SST and abundance data. To reduce the influence of outliers Boxplots were employed.

To investigate the influence of temperature on the abundance of characteristic resident Wadden Sea fish species (*Agonus cataphractus*, *Cyclopterus lumpus*, *Liparis liparis*, *Liparis montagui*, *Myoxocephalus scorpius*, *Pholis gunnellus*, *Pomatoschistus microps*, *Spinachia spinachia* and *Zoarces viviparus*) (Vorberg and Breckling, 1999), the abundance of each of these species was correlated with temperature.

To test abundance data for significant differences between sampling stations and seasons a Kruskal-Wallis test was employed. Effects between single stations and seasons were tested using a post-hoc Bonferroni corrected Wilcoxon-Rank-Sum test.

Highest abundances of each group were correlated with NAO indices. To test if time scale patterns exist between the NAO indices and peak abundances of biogeographic-habitat groups, data were correlated with NAO indices prior to peak abundances. A time-lag up to 12 months was considered (Nyitrai et al., 2013).

For all tests statistical significance was assumed if the p-value was below 0.05. Statistical analyses were calculated employing the Software R 2.15.3 (R Development Core Team, 2013). The boreal-arctic-benthopelagic and Pacific-benthopelagic groups were excluded from statistical analyses as in each group only one individual of a species (*Pungitius pungitius*, *Oncorhynchus mykiss*), assigned to these groups, were observed during the whole sampling period. For Atlantic-demersal and Atlantic-pelagic species no linear regression could be calculated due to the reason that Boxplots assigned all abundance values higher than 0.01 as outliers.

3. Results

3.1. Species composition, abundance and dispersal

In total 47 fish species were sampled during this survey (Table 1). Data sampled for this investigation revealed new species in the SRB, 2 boreal-arctic (*Liparis montagui*, *Pungitius pungitius*), 2 lusitanian (*Alosa alosa*, *Pomatoschistus lozanoi*) and 1 Pacific species (*Oncorhynchus mykiss*) (Table 1). *Oncorhynchus mykiss* was not found in other monitoring programs in the Wadden Sea (Table 1).

Table 1. Abundance per 1000 m⁻² and number of species of different biogeographic groups Atlantic, boreal-arctic, boreal, lusitanian and Pacific in different sampling years. Numbers of species sampled in each year given in parentheses. Acronyms for biogeographic-habitat groups: b (benthopelagic), d (demersal), p (pelagic). Numbers in superscript give occurrence of species in other monitorings after (Jager et al., 2009). 1: Demersal Young Fish Survey, 2: Demersal Fish Survey, 3: Stow net Schleswig Holstein, 4: Stow net Lower Saxony, 5: Stow net Elbe, 6: Vorberg and Breckling (1999); 7: Witte and Zijlstra (1978); 8: Fricke et al. (1994); 9: Herrmann et al. (1998); 10: Tulp et al. (2008). Codes for abundance data: - = 0 individuals; \emptyset = <0.01 individuals; + = 0.01 to 10 individuals; ++ = 10 to 100 ind; +++ = 100 to 200 individuals; ++++ = 200 to 1000 individuals.

species	biogeographic-habitat	2007 (38)	2008 (35)	2009 (35)	2010 (38)	2011 (33)
<i>Anguilla anguilla</i> ^{1, 2, 3, 4, 5, 6, 7, 8, 9, 10}	Atlantic d	\emptyset	-	+	-	-
<i>Pollachius virens</i> ^{1, 2, 6, 7, 8, 9, 10}	Atlantic d	-	-	-	\emptyset	-
<i>Salmo</i> spp. ^{1, 3, 4, 6, 7, 8, 9}	Atlantic p	\emptyset	\emptyset	\emptyset	\emptyset	-
<i>Scomber scombrus</i> ^{1, 2, 3, 4, 6, 7, 8, 9}	Atlantic p	-	-	-	\emptyset	-
species number Atlantic		2	1	1	3	0
<i>Agonus cataphractus</i> ^{1, 2, 3, 4, 5, 6, 7, 8, 9, 10}	boreal arctic d	+	+	+	+	+
<i>Cyclopterus lumpus</i> ^{1, 2, 3, 4, 6, 7, 8, 9, 10}	boreal arctic d	+	+	+	\emptyset	+
<i>Liparis liparis</i> ^{1, 2, 3, 4, 5, 6, 7, 8, 9, 10}	boreal arctic d	+	+	+	\emptyset	+
<i>Liparis montagui</i> ^{1, 3, 4, 5, 6, 8}	boreal arctic d	-	-	-	+	\emptyset
<i>Myoxocephalus scorpius</i> ^{1, 2, 3, 4, 5, 6, 7, 8, 9}	boreal arctic d	+	+	+	+	+
<i>Pungitius pungitius</i> ^{1, 4, 6, 8, 9}	boreal arctic b	-	-	-	\emptyset	-
<i>Zoarces viviparus</i> ^{1, 2, 3, 4, 5, 6, 7, 8, 9, 10}	boreal arctic d	+	+	+	+	+
species number boreal arctic		5	5	5	7	6
<i>Ammodytes tobianus</i> ^{1, 2, 3, 4, 6, 7, 8, 9, 10}	boreal b	+	+	+	+	+
<i>Ciliata mustela</i> ^{1, 2, 3, 4, 5, 6, 7, 8, 9, 10}	boreal d	+	+	\emptyset	+	+
<i>Clupea harengus</i> ^{1, 2, 3, 4, 5, 6, 7, 8, 9, 10}	boreal b	++	++	+++	++++	++
<i>Gadus morhua</i> ^{1, 2, 3, 4, 5, 6, 7, 8, 9, 10}	boreal d	+	+	+	+	\emptyset
<i>Gasterosteus aculeatus</i> ^{1, 2, 3, 4, 5, 6, 7, 8, 9}	boreal d	+	+	+	+	+
<i>Hyperoplus lanceolatus</i> ^{1, 2, 3, 4, 5, 6, 7, 8, 9}	boreal b	+	+	+	+	+
<i>Lampetra fluviatilis</i> ^{1, 2, 3, 4, 5, 6, 7, 8, 9, 10}	boreal d	+	\emptyset	+	+	\emptyset
<i>Limanda limanda</i> ^{1, 2, 3, 4, 6, 7, 8, 9, 10}	boreal d	+	+	+	+	+

<i>Microstomus kitt</i> ^{1, 2, 3, 4, 6, 7, 8, 9}	boreal d	-	-	+	-	+
<i>Osmerus eperlanus</i> ^{1, 2, 3, 4, 5, 6, 7, 8, 9, 10}	boreal b	+	+	+	+	+
<i>Pholis gunnellus</i> ^{1, 2, 3, 4, 6, 7, 8, 9, 10}	boreal d	+	+	+	+	+
<i>Pleuronectes platessa</i> ^{1, 2, 3, 4, 5, 6, 7, 8, 9, 10}	boreal d	+	+	+	+	+
<i>Spinachia spinachia</i> ^{1, 6, 7, 8, 9}	boreal d	∅	-	+	+	+
species number boreal		12	11	13	12	13
<i>Alosa alosa</i> ^{2, 3, 4, 7, 8}	lusitanian p	+	-	-	-	-
<i>Alosa fallax</i> ^{1, 3, 4, 5, 6, 7, 8, 9, 10}	lusitanian p	∅	-	-	+	+
<i>Aphia minuta</i> ^{2, 3, 4, 6, 7, 8, 9}	lusitanian p	-	+	+	-	-
<i>Atherina presbyter</i> ^{1, 2, 3, 4, 6, 7, 8, 9}	lusitanian p	+	+	+	+	+
<i>Belone belone</i> ^{1, 2, 3, 4, 6, 7, 8, 9}	lusitanian p	+	+	+	+	+
<i>Callionymus lyra</i> ^{1, 2, 3, 5, 6, 7, 8, 9, 10}	lusitanian d	∅	∅	∅	+	∅
<i>Chelidonichthys</i> spp. ^{1, 2, 3, 4, 5, 6, 7, 8, 9, 10}	lusitanian d	∅	+	-	∅	+
<i>Chelon labrosus</i> ^{1, 2, 3, 5, 6, 7, 8, 9}	lusitanian p	-	+	+	-	-
<i>Engraulis encrasicolus</i> ^{1, 2, 3, 4, 5, 6, 7, 8, 9}	lusitanian p	+	+	+	+	+
<i>Entelurus equorus</i> ^{1, 2, 3, 4, 5, 6, 7, 8, 9, 10}	lusitanian p	+	+	-	-	-
<i>Merlangius merlangus</i> ^{1, 2, 3, 4, 5, 6, 7, 8, 9, 10}	lusitanian d	+	+	+	+	+
<i>Mullus surmuletus</i> ^{1, 2, 3, 4, 6, 7, 8, 9}	lusitanian d	-	+	+	+	-
<i>Platichthys flesus</i> ^{1, 2, 3, 4, 5, 6, 7, 8, 9, 10}	lusitanian d	+	+	+	+	+
<i>Pomatoschistus lozanoi</i> ^{2, 7, 8}	lusitanian d	-	+	+	+	-
<i>Pomatoschistus microps</i> ^{1, 3, 4, 5, 6, 8, 9, 10}	lusitanian d	+	+	+	∅	+
<i>Pomatoschistus minutus</i> ^{1, 3, 5, 6, 7, 8, 9, 10}	lusitanian d	+	+	+	+	+
<i>Scophthalmus maxima</i> ^{1, 2, 3, 4, 5, 6, 7, 8, 9, 10}	lusitanian d	∅	-	-	-	-
<i>Scophthalmus rhombus</i> ^{1, 2, 3, 4, 5, 6, 7, 8, 9, 10}	lusitanian d	∅	-	-	-	-
<i>Solea solea</i> ^{1, 2, 3, 4, 5, 6, 7, 8, 9, 10}	lusitanian d	∅	∅	∅	∅	0
<i>Sprattus sprattus</i> ^{1, 2, 3, 4, 5, 6, 7, 8, 9, 10}	lusitanian p	+	+	+	+	++
<i>Syngnathus rostellatus</i> ^{1, 2, 3, 4, 5, 6, 7, 8, 9, 10}	lusitanian d	+	+	+	+	+
<i>Trachurus trachurus</i> ^{1, 2, 3, 4, 5, 6, 7, 8, 9}	lusitanian p	∅	+	+	+	+
species number lusitanian		18	18	16	16	14
<i>Oncorhynchus mykiss</i>	Pacific b	∅	-	-	-	-
species number Pacific		1	0	0	0	0

Sampled species were grouped in five biogeographic guilds and three vertical habitats, resulting in nine different biogeographic-habitat groups, numbers of species in parentheses Atlantic-demersal (2), Atlantic-pelagic (2), boreal-arctic-benthopelagic (1), boreal-arctic-demersal (6), boreal-benthopelagic (4), boreal-demersal (9), lusitanian-demersal (12), lusitanian-pelagic (10) and Pacific-benthopelagic (1) (Table 1). Species composition and number changed between sampling years, most species were sampled in 2007 (38) and 2010

(38) followed by 2009 (35), 2008 (35) and 2011 (33) (Table 1). In all sampling years highest abundances were found for boreal-benthopelagic species (*Clupea harengus*, *Ammodytes tobianus*) followed by lusitanian-pelagic species (*Sprattus sprattus*, *Trachurus trachurus*) and lusitanian-demersal species (*Pomatoschistus minutus*, *Merlangius merlangus*) (Table 1). Boreal-arctic and other boreal species were less abundant (Table 1).

The species number of Atlantic (1 to 3), boreal-arctic (5 to 7) and boreal species (11 to 13) appeared to be lower than lusitanian species numbers, but quite stable (Table 1). The number of lusitanian species fluctuated between 14 and 18 (Table 1).

In most cases highest abundances for different biogeographic-habitat groups were found at Stations 3, 5 or 7. The number of individuals, in percent, for each group at sampling Stations 1 to 9 is illustrated in Fig. 3. Stations 3, 5, 7 as well as 9 were situated in subtidal areas with less than 6 m water depth, inside the SRB. Combining all groups 67% of the individuals of all species were sampled in this shallow subtidal area (Fig. 3). In deeper subtidal areas inside the SRB, Stations 2, 4, and 6 about 10% of individuals were sampled (Fig. 3). In the open North Sea, Stations 1 and 8, about 23% of individuals were observed (Fig. 3).

3.2. Seasonal species composition and abundance

Comparing the abundance at sampling Station 1 to 9 in different seasons the high proportion of boreal-benthopelagic fish was clearly visible (Fig. 4). In fall and winter the percentage of boreal-arctic-demersal, boreal-demersal, lusitanian-demersal and lusitanian-pelagic species increased (Fig. 4). In winter and fall species number was lower compared to spring and summer (Table 2). In all seasons highest individual numbers were found for boreal-benthopelagic species *C. harengus* and *A. tobianus*, while the abundances peaked in summer (Table 2).

In Fig. 5 the proportions of biogeographic-habitat groups in different seasons are presented. While in summer and spring proportions of Atlantic-demersal (spring 10%, summer 90%), Atlantic-pelagic (spring 30%, summer 70%), boreal-benthopelagic (winter 3%, spring 28%, summer 62%, fall 7%) and Pacific-benthopelagic (summer 100%) were high, but decreased in fall and winter (Fig. 5), highest abundances of boreal-arctic-benthopelagic (fall 100%); boreal-arctic-demersal (winter 61%, spring 11%, summer 15%, fall 13%) and boreal-demersal individuals (winter 35%, spring 17%, summer 31%, fall 17%) were found at the end of the year (Fig. 5).

Individuals of lusitanian-demersal (winter 12%, spring 9%, summer 30%, fall 48%) and lusitanian-pelagic individuals (winter 16%, spring 24%, summer 38%, fall 22%) were more equally distributed through seasons (Fig. 5), but were showing a focus towards higher water temperatures in summer and fall. Combining all biogeographic-habitat groups highest proportion of individuals occurred in summer (59%) and spring (27%), followed by fall (9%) and winter (5%) (Fig. 5).

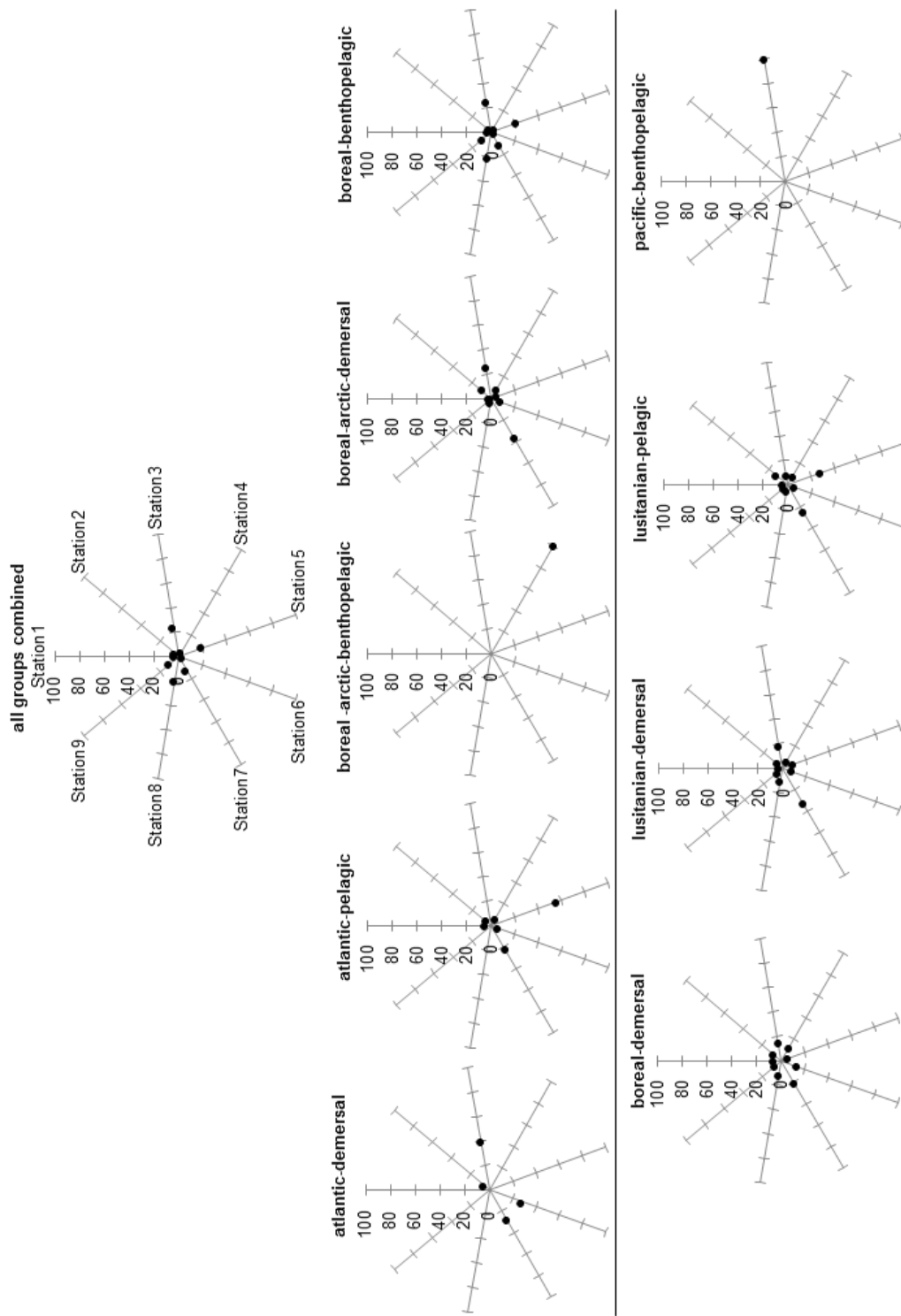

Fig. 3. Percentage of occurrence of all individuals, at different sampling stations over a 5 year period for combined biogeographic-habitat groups and for each biogeographic-habitat group separately.

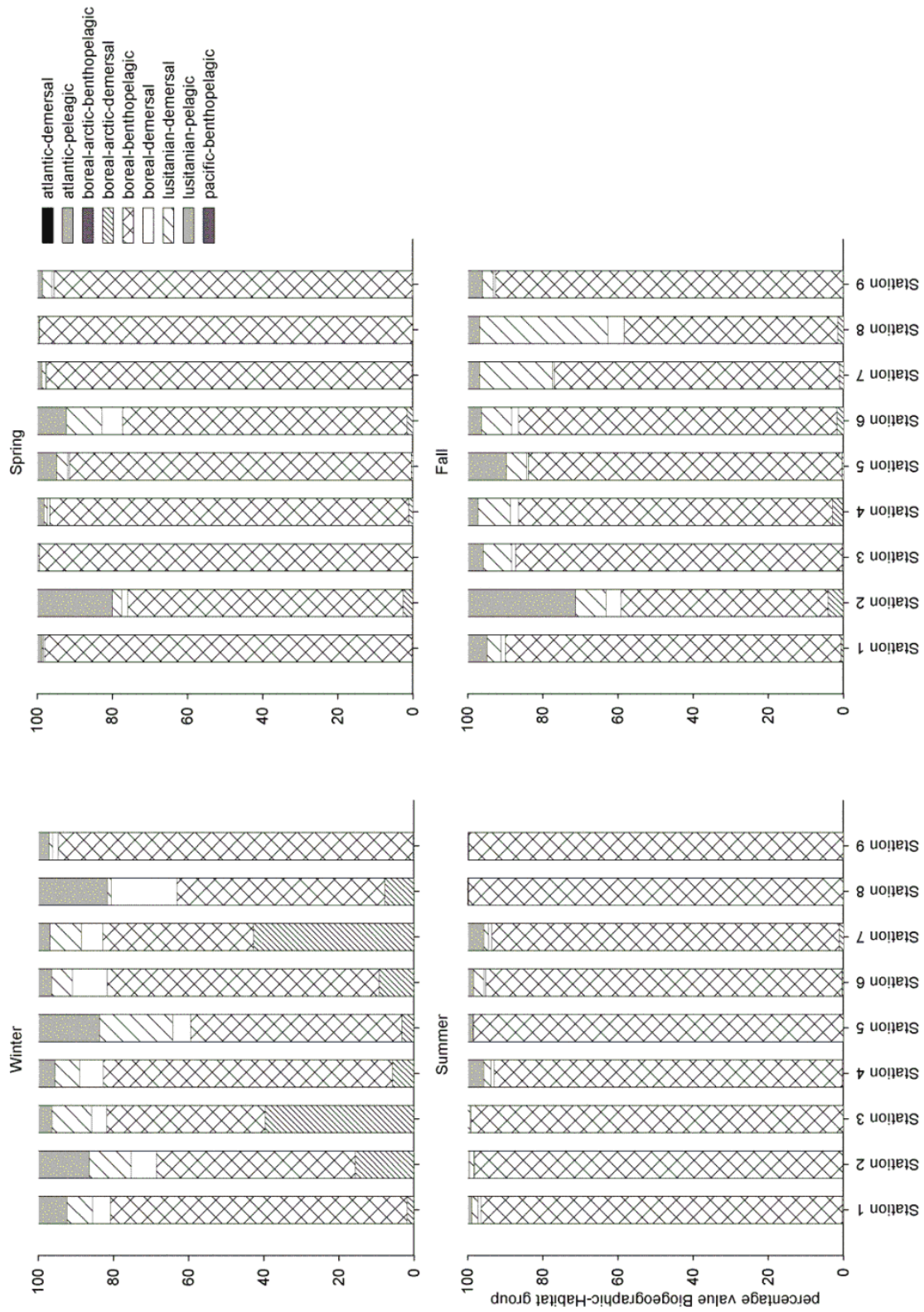

Fig. 4. Percentage value of different biogeographic-habitat groups at sampling stations in different seasons.

Table 2. Abundance per 1000 m⁻² of species in different seasons over a period of 5 years. Codes for abundance data: - = 0 individuals; ø = <0.01 individuals; + = 0.01 to 10 individuals; ++ = 10 to 100 ind; +++ = 100 to 200 individuals; ++++ = 200 to 1000 individuals; +++++ = > 1000 individuals.

Species	Winter	Spring	Summer	Fall
<i>Agonus cataphractus</i>	+	+	+	+
<i>Alosa alosa</i>	-	-	+	-
<i>Alosa fallax</i>	-	-	+	+
<i>Ammodytes tobianus</i>	+	++	+++	++
<i>Anguilla anguilla</i>	-	+	+	-
<i>Aphia minuta</i>	-	+	+	-
<i>Atherina presbyter</i>	-	+	+	+
<i>Belone belone</i>	+	+	+	+
<i>Callionymus lyra</i>	-	+	+	+
<i>Chelidonichthys</i> spp.	-	-	+	+
<i>Chelon labrosus</i>	-	-	+	+
<i>Ciliata mustela</i>	+	+	+	+
<i>Clupea harengus</i>	+++	+++++	+++++	+++++
<i>Cyclopterus lumpus</i>	+	+	+	+
<i>Engraulis encrasicolus</i>	-	+	+	+
<i>Entelurus aequoreus</i>	+	+	+	+
<i>Gadus morhua</i>	+	+	+	+
<i>Gasterosteus aculeatus</i>	+	+	+	+
<i>Hyperoplus lanceolatus</i>	+	+	+	+
<i>Lampetra fluviatilis</i>	+	+	+	+
<i>Limanda limanda</i>	+	+	+	+
<i>Liparis liparis</i>	+	+	+	+
<i>Liparis montagui</i>	-	+	+	+
<i>Merlangius merlangus</i>	+	+	++	++
<i>Microstomus kitt</i>	-	-	+	+
<i>Mullus surmuletus</i>	-	-	+	+
<i>Myoxocephalus scorpius</i>	++	+	+	+
<i>Oncorhynchus mykiss</i>	-	-	+	-
<i>Osmerus eperlanus</i>	+	+	+	+
<i>Pholis gunnellus</i>	+	+	+	+
<i>Platichthys flesus</i>	+	+	+	+
<i>Pleuronectes platessa</i>	+	+	+	+
<i>Pollachius virens</i>	-	-	+	-
<i>Pomatoschistus lozanoi</i>	+	+	+	+
<i>Pomatoscistus microps</i>	+	+	++	++
<i>Pomatoschistus minutus</i>	+	+	+	+
<i>Pungitius pungitius</i>	-	-	-	+
<i>Salmo</i> spp.	-	+	+	-
<i>Scomber scombrus</i>	-	-	+	-
<i>Scophthalmus maxima</i>	+	-	-	-
<i>Scophthalmus rhombus</i>	+	-	-	-
<i>Solea solea</i>	-	+	+	+
<i>Spinachia spinachia</i>	+	+	+	+
<i>Sprattus sprattus</i>	++	++	++	++
<i>Syngnathus rostellatus</i>	+	+	++	++
<i>Trachurus trachurus</i>	-	-	++	+
<i>Zoarces viviparus</i>	+	+	+	+

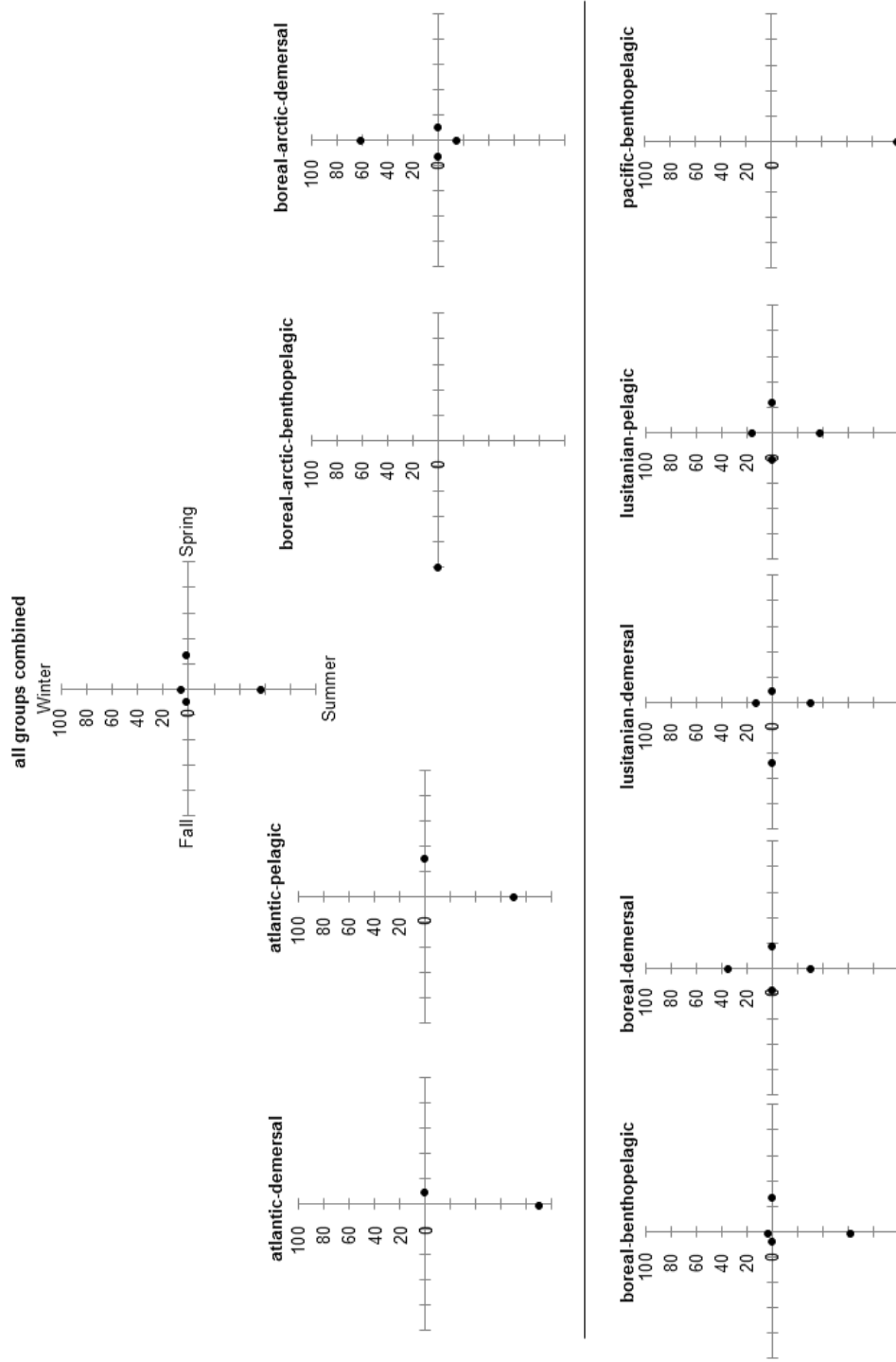

Fig. 5. Percentage of occurrence of all individuals, in different seasons over a 5 year period for combined biogeographic-habitat groups and for each biogeographic-habitat group separately.

3.3. Diversity indices

Comparing indices (H' , $1 - D$, J) for sampling Stations 1 to 9, highest values were calculated at Station 6 (0.56, 0.36, 0.48), Station 1 (0.43, 0.28, 0.41), Station 2 (0.42, 0.27, 0.38) and Station 4 (0.42, 0.27, 0.37) indicating higher diversity and species equality (Table 3). These stations were located in subtidal areas below 6 m except of Station 1 which was situated inside the SRB. Lower values were calculated for stations in shallower areas of the SRB. Lowest diversity and species equality were found at Station 8 situated in the open North Sea in front of the outflow of the tidal inlet from the bight.

Regarding different seasons highest diversity indices were found in winter (0.81, 0.56, 0.73) and fall (0.69, 0.44, 0.67) (Table 3). Lower values in spring and summer do not indicate lower species richness, but particularly less equability of species abundance (Table 3). Comparing H' and $1 - D$ higher values were calculated for the H' index, except in spring (Table 3). This index is sensitive towards the change of rare species.

Table 3. Diversity indices for different sampling stations and seasons. H' Shannon-index; J Evenness-index; $(1-D)$ Simpson index of Diversity.

	H'	J	$1 - D$
Station 1	0.43	0.28	0.41
Station 2	0.42	0.27	0.38
Station 3	0.20	0.13	0.16
Station 4	0.42	0.27	0.37
Station 5	0.24	0.16	0.23
Station 6	0.56	0.36	0.48
Station 7	0.39	0.25	0.38
Station 8	0.12	0.09	0.09
Station 9	0.16	0.12	0.13
Winter	0.81	0.56	0.73
Spring	0.33	0.22	0.35
Summer	0.25	0.15	0.22
Fall	0.69	0.44	0.67

3.4. Correlation between abundance and local abiotic factors

According to the Saphiro-Wilks test data showed no normal distribution and correlations were calculated employing two-tailed Kendals- τ test for non-parametric data (Table 4). Values of Kendals- τ are given in parentheses. Abundance was significantly positively related to temperature, in descending order, for boreal-benthopelagic (0.58), and lusitanian-demersal (0.35) species (Table 4). These relationships were positive, as high abundances were observed at higher temperatures. Negative significant correlations were found for boreal-arctic-demersal (-0.28) species (Table 4), indicating lower abundances at higher temperatures. Data of temperature and abundance are illustrated in Fig. 6.

Regression analyses considering temperature and abundance of different biogeographic-habitat groups are given in Fig. 7. A significant positive relationship was found for boreal-benthopelagic species ($R^2 = 0.25$, $p = 0.04$). Relationships for other biogeographic-groups were found not to be significant, as p-values are higher than 0.05, but may indicate possible trends for future developments (Fig. 7).

Correlating abundance data and depth gave significant negative relationships calculated for lusitanian-demersal (-0.07) species (Table 4). Calculations gave significant positive correlations between salinity and abundance for boreal-benthopelagic (0.09) and lusitanian-demersal (0.07) species (Table 4). Significant negative correlations were calculated for boreal-demersal (-0.13) species (Table 4).

Significant differences between stations situated in shallow and deeper areas were found for boreal-demersal, lusitanian-demersal and lusitanian-pelagic species (Table 4). Statistical tests revealed significant differences of fish abundance between seasons for all groups except Atlantic-pelagic (Table 4).

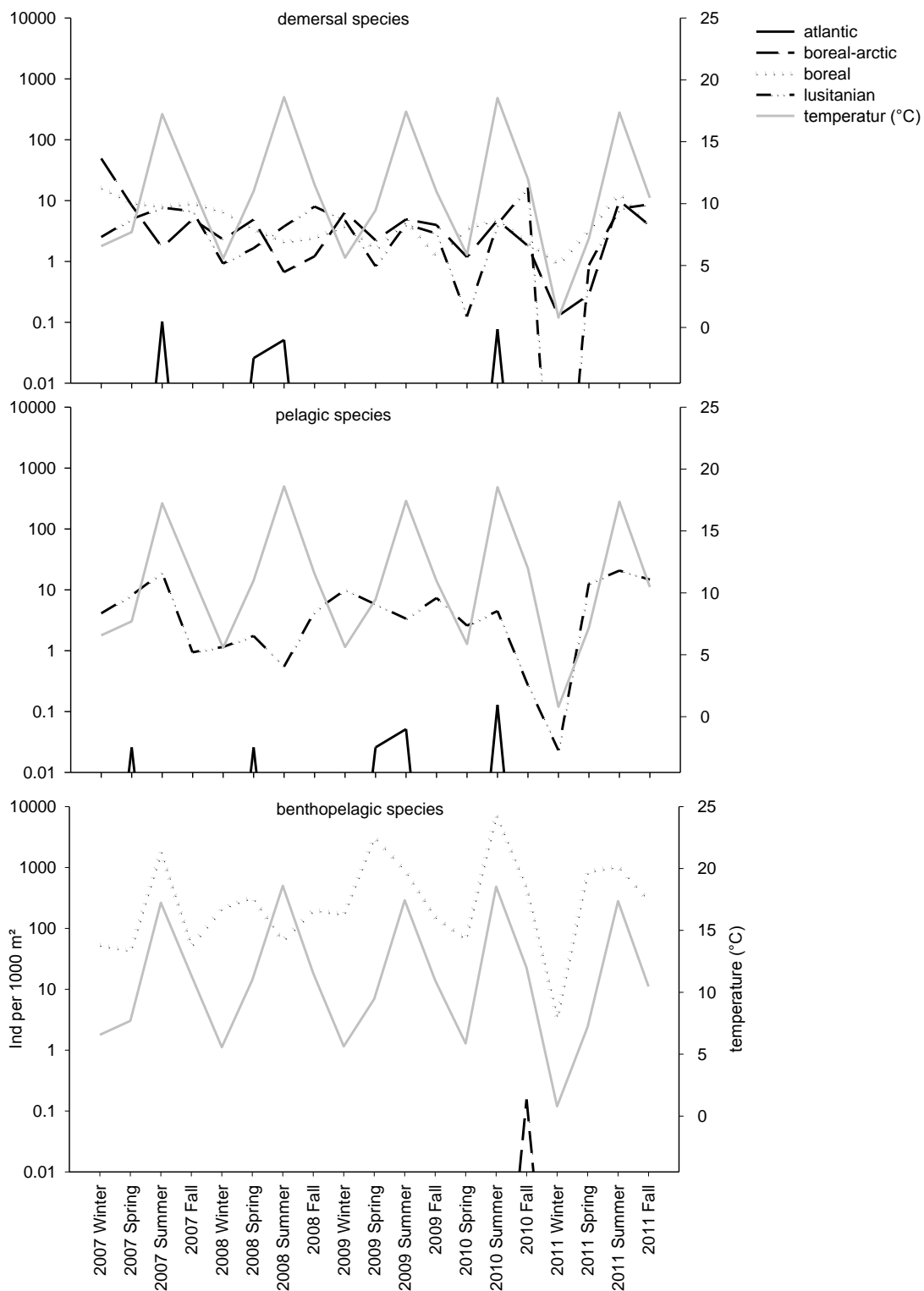

Fig. 6. Fluctuation of abundance of biogeographic-habitat groups in vertical habitats compared to temperature (°C) in different seasons. Note logarithmic scale of individuals (Ind) per 1000 m⁻² axis.

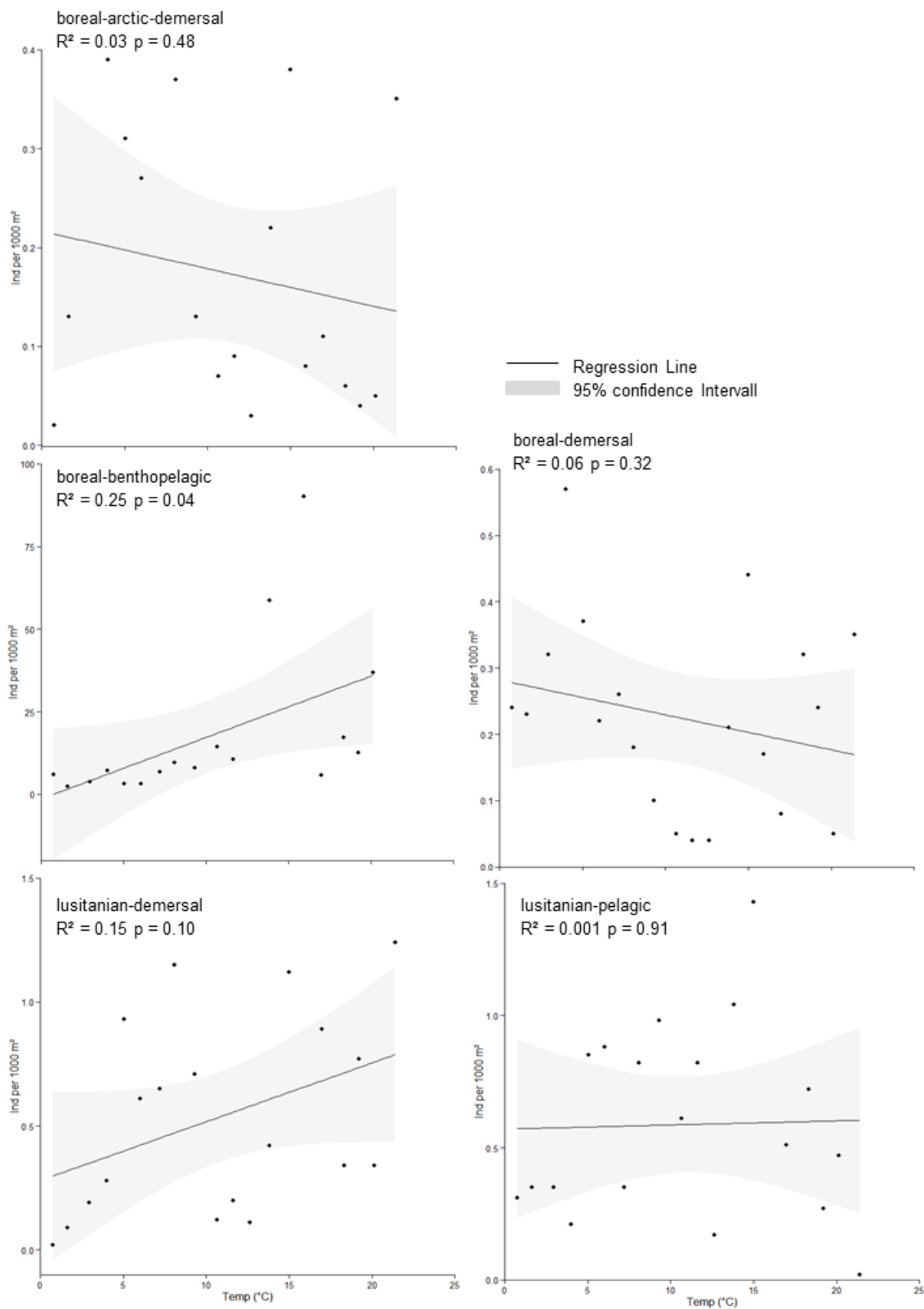

Fig 7. Linear regressions between temperature (°C) and individual abundance of different biogeographic-habitat groups. Note different scale on y-axis.

For characteristic resident Wadden Sea species the following correlations between temperature and abundance were observed (significant correlations are indicated by asterisk): *A. cataphractus** (Kendalls- τ : -0.34; p-value: 0.02), *C. lumpus* (Kendalls- τ : -0.22; p-value: 0.10), *L. liparis* (Kendalls- τ : 0.24; p-value: 0.08), *L. montagui* (Kendalls- τ : 0.21; p-value: 0.12), *M. scorpius** (Kendalls- τ : -0.42; p-value: 0.005), *P. gunnellus* (Kendalls- τ : 0.10; p-value: 0.28), *P. microps** (Kendalls- τ : -0.49; p-value: 0.002), *P. minutus* (Kendalls- τ : 0.15; p-value: 0.19), *S. spinachia* (Kendalls- τ : 0.09; p-value: 0.31), *Z. viviparus* (Kendalls- τ : 0.03; p-value: 0.42).

3.5. Impact of a climate large scale oscillation

Correlations between peak abundances of biogeographic-habitat groups and NAO indices were found for various time-lags. Atlantic species are significantly impacted by NAO 7, 10 and 11 months before peak abundances (Table 4). For Atlantic-demersal species peak abundances during lower NAO values were observed, while abundance peaks for Atlantic-pelagic species occurred during times of higher values (Table 4). While NAO influences peak abundances of boreal-demersal species 6 months prior, correlations with highest abundances of boreal-benthopelagic species gave ambiguous results (Table 4). For boreal-demersal species highest abundances were found during periods of lower NAO values (Table 4). NAO affects highest abundances of lusitanian-demersal species 1 month before (Table 4). Peak abundances of lusitanian-pelagic species are affected 2 to 3 months prior (Table 4). Peak abundances of lusitanian-demersal species occurred in periods with lower NAO indices, lusitanian-pelagic in periods of higher indices.

Table 4. Results of statistic calculations b (benthopelagic), d (demersal), p (pelagic), obs dif (observed differences), NAO (North Atlantic Oscillation). Significance codes 0.05*, 0.01**, 0.001***, 0.0001****.

	Atlantic-d	Atlantic-p	boreal-arctic-d	boreal-b	boreal-d	lusitanian-d	lusitanian-p
normal distribution							
Shapiro-Wilk (W)	0.11***	0.07***	0.18***	0.25***	0.41***	0.21***	0.23***
temperature vs abundance							
Kendalls- τ (2-tailed)	0.27	0.15	-0.28*	0.58****	-0.19	0.35**	0.06
depth vs abundance							
Kendalls- τ (2-tailed)	-0.01	-0.01	-0.03	0.03	0.04	-0.07*	0.05
salinity vs abundance							
Kendalls- τ (2-tailed)	0.07	0.04	-0.01	0.09**	-0.13****	0.07*	-0.03
differences between stations							
Kruskal-Wallis (H)	-	-	-	-	23.65*	42.83****	21.23**
Wilcoxon-Rank sum: obs dif							
Station 1 vs Station 3	-	-	-	-	-	141.97***	-
Station 1 vs Station 5	-	-	-	-	-	-	-
Station 1 vs Station 7	-	-	-	-	-	142.17****	-
Station 2 vs Station 3	-	-	-	-	-	116.45**	-
Station 2 vs Station 7	-	-	-	-	-	116.66**	-
Station 3 vs Station 4	-	-	-	-	-	123.61**	-
Station 4 vs Station 5	-	-	-	-	-	-	117.51**
Station 4 vs Station 7	-	-	-	-	-	123.82**	-
Station 5 vs Station 8	-	-	-	-	77.69*	-	-

Kruskal-Wallis (H)	13.02*	-	14.23**	25.08****	12.93**	56.34****	10.56*
Wilcoxon-Rank sum: obs dif							
W vs Sp	-	-	58.17**	-	47.8*	-	-
W vs S	-	-	53.61**	60.59**	-	85.62****	-
W vs F	-	-	49.93*	-	56.36**	89.54****	-
Sp vs S	-	-	-	75.27***	-	118.96****	-
Sp vs F	-	-	-	-	-	122.89****	-
NAO vs highest abundance							
Kendalls-τ (2-tailed)							
NAO (time-lag 1 month)	-	-	-	-	-	-1.00*	-
NAO (time-lag 2 months)	-	-	-	-	-	-	1.00*
NAO (time-lag 3 months)	-	-	-	-	-	-	0.80*
NAO (time-lag 6 months)	-	-	-	0.74*	-0.80*	-	-
NAO (time-lag 7 months)	-	0.56**	-	-	-	-	-
NAO (time-lag 8 months)	-	-	-	0.74*	-	-	-
NAO (time-lag 10 months)	-0.27*	-	-	-0.80*	-	-	-
NAO (time-lag 11 months)	-	0.42**	-	-	-	-	-

4. Discussion

During this survey 5 fish species were caught, which were not found in previous investigations. Comparing the data with those of Herrmann et al. (1998) species composition changed as 3 boreal (*Ammodytes marinus*, *Coregonus oxyrinchus* and *Taurulus bulbalis*) and 4 lusitanian species (*Buglossidium luteum*, *Maurollicus muelleri*, *Syngnathus acus* and *Trisopterus luscus*) were not found during this study.

Higher species numbers found by Herrmann et al. (1998) might be based on sampling in intertidal areas, which were not considered in the present investigation. This might also be a reason for a more diverse species composition although none of the above mentioned species was sampled by Kellnreitner et al. (2012) and preceding campaigns in 2006 (Pockberger and Kellnreitner, unpublished data) considering inter- and subtidal areas.

The absence of 4 lusitanian species (but found by Herrmann et al., 1998) and occurrence of new boreal-arctic (*L. montagui*, *P. pungitius*) species in the present study, seems to contradict the prediction of increasing proportions of thermophile species in relation to increased temperature established by Westernhagen (1993).

The higher number of lusitanian species found in previous investigations may also be explained by the mildest winter series in the North Sea in combination with relatively warm summers, between 1989 and 1994, in the last fifty years (Becker and Pauly, 1996). Comparing temperatures, measured during this investigation, to the Ecological Time Series of the AWI in the North Sea, shows relatively warm summers between 2007 and 2011. Comparison of previous investigations and the present results might indicate the importance and impact of cold winters on species occurrence and abundance in the Wadden Sea, as the present data were sampled during a series of colder winters (2007-2011). The decrease in temperature is probably based on the cooling of the tropical Pacific (Kosaka and Xie, 2013).

Held (2013) described, based on decreasing Pacific water temperatures, a low increase of the global mean temperature was observed, causing colder winters in the Northern hemisphere. Kosaka and Xie (2013) concluded the cooling of the Pacific may be due to natural variability and if water temperatures increase, global warming and climate change will resume.

The SRB, although not an estuary, seems to be an important transitional water system, as 1 katadromous (*Anguilla anguilla*), 6 anadromous species (*Alosa fallax*, *Alosa alosa*, *G. aculeatus*, *L. fluviatilis*, *O. mykiss*, *O. eperlanus*) and 1 anadromous genus (*Salmo* spp.) were found. As mentioned above no individuals of the anadromous houting *C. oxyrinchus* were caught. Although the reestablishment of a houting population into the rivers Brede Å and Vidå flowing in the investigation area was successful, this species is still threatened due to low reproduction success (Jepsen et al., 2012) and especially the fate of their marine life stages need further investigation. For other migrating species, such as *Salmo salar* (Atlantic salmon) and *Salmo trutta trutta* (Sea trout), which have been lost in rivers discharging into the SRB, the measurements of the project proved to be beneficial (Jepsen et al., 2012). The occurrence of *O. mykiss* (brown- or steelhead trout) in the SRB might be explained by aquaculture and stocking programs for recreational fishery. This species is regularly found in southern parts of the Wadden Sea (Hartgers et al., 1998) and might migrate to other regions. If the occurrence of introduced top predators, as the steelhead trout, reaches higher numbers than observed, it can influence native species feeding on the same level and impact the whole ecosystem by foraging, introduction of parasites, disease and habitat alteration (Crowl et al., 1992; Naylor et al., 2005).

The species list presented in this investigation might not be exhaustive, as firstly the Wadden Sea is an open system towards the North Sea (Vorberg and Breckling, 1999), and secondly

fast swimming and large fish (e.g. *Scomber scombrus*, *Belone belone*) might be underrepresented, as they are able to avoid sampling gear. According to published literature, data of the here described 47 species presents good coverage of the fish fauna in the SRB. Previous investigations in the SRB (Herrmann et al., 1998) describe 50 species sampled between August 1990 and October 1994 occurring regularly. For the whole Wadden Sea between 113 and 137 marine fish species are recorded (Fricke et al., 1994; Jager et al., 2009). Vorberg and Breckling (1999) describe 63 fish species for northern parts of the Wadden Sea including estuaries of the river Elbe. Anders and Möller (1991) found 46 and Hinz (1989) 33 species. Analysing data of the Demersal Fish Survey (DFS) sampled within 36 years Tulp et al. (2008) found 34 species occurring regularly in southern parts of the Wadden Sea.

Although 14 to 18 species were found to be lusitanian, which is the major group of biogeographic-habitat groups, boreal-benthopelagic species were found most abundant in all seasons. Some of the most frequently observed species (*A. tobianus*, *C. harengus*, *M. merlangus*, *P. minutus*, *S. sprattus*) were also found in previous investigations (Herrmann et al., 1998; Vorberg and Breckling, 1999) in high abundances. The lusitanian *T. trachurus* is described as seasonal visitor with high year to year variability (Philippart et al., 1996). Increasing abundances of this species might be favored by increasing water temperatures (Vorberg and Breckling, 1999).

Between 2007 and 2011 the number of lusitanian species fluctuated strongly and some species were only sampled within one or two years. In 2006 high abundances of the lusitanian *E. aequoreus* and two individuals of the boreal species *S. spinachia* were sampled by Polte and Buschbaum (2008). These planktivorous and benthivorous species depend on dense subtidal plant canopies and are threatened since the loss of these habitats (Berg et al.,

1996; Polte and Buschbaum, 2008). While *E. aequoreus* was only observed in 2006 and 2007, *S. spinachia* was since then found regularly and in slightly increasing abundances. In a survey of dense algal canopies in 2010 *S. spinachia* was found to be abundant, but no individuals of *E. aequoreus* were sampled, probably due to unfavorable conditions (Pockberger and Kellnreitner, unpublished data). Fluctuations of lusitanian species are also described by Tulp et al. (2008) who stated increasing, but also decreasing abundances for lusitanian species, concluding that these species show a stronger response to environmental factors compared to boreal species.

During this investigation shallow coastal areas were compared to areas situated in the North Sea (Stations 1, 8), regarding the spatial distribution, 67% of all individuals were sampled in depths between 2.8 and 5.5 m, indicating the importance of shallow coastal habitats. A reason for the high proportion in these depths might be that the major part of the fish fauna in the SRB consisted of juvenile individuals. Shallow Wadden Sea areas provide important nurseries for fish due to abundant prey items and diverse habitats (Tulp et al., 2008; Vorberg and Breckling, 1999; Zijlstra, 1972). Although the most abundant species in the SRB depend on zooplankton as a food source, 29 fish species are described as demersal and depend strongly on benthic food, such as macrofaunal prey items (Kellnreitner et al., 2012). According to Armonies and Reise (2003) high species richness for macrofauna is found in “shallow to medium” depths of subtidal areas, while below 10 meters species richness is low, providing less prey species for fish, probably due to sediment conditions and local currents. While highest abundances of fish were found in shallower subtidal parts of the SRB, calculated indices give highest fish species richness below 6 m, probably due to more stable conditions in these areas (Vorberg and Breckling, 1999). Statistical analyses of data show only for lusitanian-demersal species a significant correlation between abundances and

depth. Perry et al (2005) describe the migration of six species towards deeper areas, probably due to changing climate conditions. The low impact of water depth on abundance might be explained by the homogenous water temperature in the well mixed tidal waters. Results reveal seasonal abundances, patterns and the temperature preference of different biogeographic-habitat groups. Accordingly highest proportions of species preferring higher temperatures (Atlantic, boreal-benthopelagic, lusitanian) were found in warmer seasons. The majority of individuals of cryophilic species (boreal-arctic-benthopelagic, boreal-arctic-demersal, boreal-demersal) were sampled in late fall and winter. These temperature induced patterns may not be surprising, but statistical analyses point out the negative impact of increasing temperatures on the species abundance of cryophilic biogeographic-habitat groups.

Surprisingly highest species richness was calculated in fall and winter, which is in contradiction to published literature e.g. Vorberg and Breckling (1999). While in fall higher SST than in spring were measured, providing favorable conditions for fish, most species migrate to deeper waters of the North Sea in winter, where temperatures are more stable (Kellnreitner et al., 2012). The dominance of boreal-benthopelagic species, especially in summer and spring, might be a reason for lower diversity indices and unbalanced species abundance in these seasons. The high proportion of boreal-benthopelagic is based on the high abundance of planktivores *C. harengus* and *A. tobianus*.

Lusitanian-pelagic planktivores as *Atherina presbyter* (sand smelt) and *Engraulis encrasicolus* (anchovy) were found in warmer seasons but were absent in winter. As well for sand smelt as for anchovy juvenile individuals were sampled, indicating favorable conditions for immigration, dispersal and possibly reproduction (Nawratil, 2009).

While no juvenile individuals of anchovy have been observed in the northern Wadden Sea by other authors since 2004 (Jager et al., 2009), in southern parts of Wadden Sea and North Sea larvae and juveniles were caught regularly (Alheit et al., 2012; Kanstinger and Peck, 2009). Individuals of different life stages of sand smelt were abundant regularly in the SRB (Herrmann et al., 1998; Polte and Asmus, 2006). These species were found for the first time in the 1990`s in North Sea and Wadden Sea (Alheit et al., 2012, Herrmann et al., 1998) and may be food competitors for native planktivores (Kellnreitner et al., 2012; Raab et al., 2011). The majority of characteristic resident species for Wadden Sea areas are boreal-arctic and boreal species (Vorberg and Breckling, 1999) and can be affected by increased winter temperatures (Pörtner and Knust, 2007). Abundances of characteristic resident species in the here presented data appear, although fluctuating, quite stable. Calculated correlations might help to understand changes in species abundance in a warming Wadden Sea. But it should be noted that the future fate of characteristic resident Wadden Sea species cannot be answered fully by this investigation, as the sampling period may be still too short. Continuing monitoring in the SRB is necessary to detect long-term trends.

In the QSR 2009 data of several fish monitoring sampled over 30 years in the Wadden Sea are presented by Jager et al. (2009) and 14 priority species are defined. For these 8 boreal and 6 lusitanian species more often declining than increasing abundances were observed (Jager et al., 2009).

Statistical significant correlations between NAO indices and fish abundance in the SRB were found. Results indicate that the vertical habitats (benthopelagic, demersal, pelagic) in which the species forage are related to NAO. There seem to be no significant correlations between the biogeographic-groups (Atlantic, boreal-artic, boreal, lusitanian) or the temperature preference of fish with NAO indices. While correlations between highest abundances of

benthopelagic species and NAO reveal no clear pattern, peak abundances of demersal species were observed during periods of lower NAO values. In turn peak abundances of pelagic species occurred during times of higher values. Martens (2001) described significant correlations between the NAO winter index and abiotic respectively biotic parameters, affecting environmental conditions in the SRB. Tulp et al. (2008) found no significant correlation between the NAO winter index and fish species in the Wadden Sea, but describe an impact of changing abiotic parameters on different feeding types. As shown in the present results other investigations on fish populations and communities give significant relationships between abundance and growth and the NAO (Attrill and Power, 2002; Henderson, 2007; Henriques et al., 2007). On a species level, Sims et al. (2004) described changes in the time of the beginning of spawning migration of *P. flesus* depending on prevailing NAO. Henderson and Seaby (2005) correlated abundance and growth of *Solea solea* to NAO and found significant relationships especially for juvenile growth. Time lagged effects of NAO, influencing the abundance of *P. microps*, up to 12 months later, are described by Nyitrai et al. (2013).

Reasons for the observed time-lags might be the impact of large scale climate factors (e.g. NAO) on the recruitment, ontogeny, growth, and migration patterns influencing the productivity of species in a fish community, as mentioned in the previous paragraph. The impacts on different periods of life affect the abundance of fish after a certain period of time (Attrill and Power, 2002; Henderson and Seaby, 2005; Sims et al., 2004; Svendsen et al., 1991). Nye et al. (2013) focusing on the effects of the Atlantic Multidecadal Oscillation conclude, that investigating the multitude influences on abiotic and biotic parameters of climate oscillations, will help in the integral recognition of ecosystem processes. Our findings based on high temporal resolution samplings give an insight on the effect of large scale

oscillations affecting fish migration in the North Sea and Wadden Sea and might help to understand the interaction of living components and ecological background processes.

5. Conclusions

In this investigation a typical fish community of boreal coastal waters was observed monthly over a period of 5 years and the impacts of climate factors on fish of different geographic origins are presented. Results showed clearly the relation of the species groups to high or low SST, whereas a relation to an overarching climate scenario such as the NAO was depending on different time-lags in the certain groups. Analyses considering the presence of different ontogenetic stages of species as well as additional attributes such as cycles of spawning or hatching may reveal further and clearer patterns of impacts on the fish community.

Even if the sampling period of five years may be too short identifying long-term trends, the results give insights into the influence of local abiotic parameters and the impact of large-scale climate systems on a fish community in a boreal coastal area. Calculated correlations and regressions reveal possible developments of fish species of different biogeographic origins in an area, subjected to changing abiotic conditions and endangered by changing climatic conditions, e.g. increasing temperatures.

Acknowledgements

We wish to thank Margit Ludwig Schweikert, Tatyana Romanova and the crew of the RV MYA, Alfred Resch and Kai von Bohlen, for their advice regarding sampling gear and sharing their experience in field work. We are indebted to all the students who helped and participated in the fish survey.

References Chapter I

- Alheit, J., Pohlmann, T., Casini, M., Greve, W., Hinrichs, R., Mathis, M., O'Driscoll, K., Vorberg, R., Wagner, C., 2012. Climate variability drives anchovies and sardines into the North and Baltic Seas. *Prog. Oceanogr.* 96, 128–139.
- Anders, K., Möller, H., 1991. Epidemiologische Untersuchungen von Fischkrankheiten im Wattenmeer, in: *Berichte aus dem Institut für Meereskunde an der Christian-Albrechts-Universität Kiel Nr. 207*. Christian-Albrechts-Universität, Kiel, p. 166.
- Armonies, W., Reise, K., 2003. Empty habitat in coastal sediments for populations of macrozoobenthos. *Helgol. Mar. Res.* 279–287. doi:10.1007/s10152-002-0129-8
- Asmus, H., Asmus, R., 2000. Material exchange and food web of seagrass beds in the Sylt-Rømø bight: how significant are community changes at the ecosystem level? *Helgol. Mar. Res.* 54, 137–150.
- Attrill, M.J., Power, M., 2002. Climatic influence on a marine fish assemblage. *Nature* 417, 275–278. doi:10.1038/417275a
- Bayerl, R., Köster, K., 1998. Morphodynamik des Lister Tidebeckens, in: Gätje, C., Reise, K. (Eds.), *Ökosystem Wattenmeer - Austausch-, Transport- Und Stoffumwandlungsprozesse*. Springer, Berlin, Heidelberg, New York, pp. 25–29.
- Becker, G.A., Pauly, M., 1996. Sea surface temperature changes in the North Sea and their causes. *ICES J. Mar. Sci.* 887–898.
- Berg, S., Krog, C., Muus, B., Nielsen, J., Fricke, R., Berghahn, R., Neudecker, T., Wolff, W., 1996. IX. Red List of Lampreys and marine fishes of the Wadden Sea. *Helgol. Mar. Res.* 50, 101–105.
- Beukema, J.J., 1992. Dynamics of juvenile shrimp *Crangon crangon* in a tidal-flat nursery of the Wadden Sea after mild and cold winters. *Mar. Ecol. Prog. Ser.* 83, 157–165.
- BSH, 2012. *Monitoring-Kennblatt Fische*. Bundesamt für Seeschifffahrt und Hydrographie (BSH) Sekretariat Bund/Länder-Messprogramm für die Meeresumwelt von Nord- und Ostsee (BLMP), Hamburg.
- Clarke, K., Gorley, R., 2006. *PRIMER v6: User Manual/Tutorial*. PRIMER-E, Plymouth.
- Collie, J.S., Wood, A.D., Jeffries, H.P., 2008. Long-term shifts in the species composition of a coastal fish community. *Can. J. Fish. Aquat. Sci.* 65, 1352–1365. doi:10.1139/F08-048
- Corten, A., 1990. Long-term trends in pelagic fish stocks of the North Sea and adjacent waters and their possible connection to hydrographic changes. *Netherlands J. Sea Res.* 25, 227–235.

-
- Corten, A., Kamp, van de G., 1996. Variation in the abundance of southern fish species in the southern North Sea in relation to hydrography and wind. *ICES J. Mar. Sci.* 53, 1113–1119.
- Crowl, T., Townsend, C.R., McIntosh, A.R., 1992. The impact of introduced brown and rainbow trout on native fish: the case of Australasia. *Rev. Fish Biol. Fish.* 2, 217–241. doi:10.1007/BF00045038
- Daan, N., Richardson, K., Pope, J.G., 1996. Changes in the North Sea ecosystem and their causes : Århus 1975 Revisited Introduction. *ICES J. Mar. Sci.* 53, 879–883.
- Dippner, J.W., 1997. Recruitment success of different fish stocks in the North Sea in relation to climate variability. *J. Hydrogr.* 49, 277–293. doi:10.1007/BF02764039
- Dulvy, N.K., Rogers, S.I., Jennings, S., Stelzenmiller, V., Dye, S.R., Skjoldal, H.R., 2008. Climate change and deepening of the North Sea fish assemblage: a biotic indicator of warming seas. *J. Appl. Ecol.* 45, 1029–1039. doi:10.1111/j.1365-2664.2008.01488.x
- Edwards, M., Beaugrand, G., Reid, P.C., Rowden, A.A., Jones, M.B., 2002. Ocean climate anomalies and the ecology of the North Sea. *Mar. Ecol. Prog. Ser.* 239, 1–10.
- Fricke, R., Berghahn, R., Rechlin, O., Neudecker, T., Winkler, H., Bast, H.-D., Hahlbeck, E., 1994. Rote Liste und Artverzeichnis der Rundmäuler und Fische (Cyclostomata Pisces) im Bereich der deutschen Nord- und Ostsee., in: Nowak, E., Blab, J., Bless, R. (Eds.), Rote Liste Der gefährdeten Wirbeltiere in Deutschland. Kilda, pp. 157–176.
- Froese, R., Pauly, D., 2010. FishBase. <http://www.fishbase.org> (accessed 18 Aug 2014).
- Gätje, C., Reise, K., 1998. Ökosystem Wattenmeer - Austausch-, Transport- und Stoffumwandlungsprozesse. Springer, Berlin, Heidelberg, New York.
- Harley, C.D.G., Randall Hughes, A., Hultgren, K.M., Miner, B.G., Sorte, C.J.B., Thornber, C.S., Rodriguez, L.F., Tomanek, L., Williams, S.L., 2006. The impacts of climate change in coastal marine systems. *Ecol. Lett.* 9, 228–41. doi:10.1111/j.1461-0248.2005.00871.x
- Hartgers, E., Buijse, A., Dekker, W., 1998. Salmonids and other migratory fish in lake IJsselmeer. EHR-Publication 76-1998. Netherlands Inst. Fish. Res. RIVO-DLO, Ijmuiden Inst. Integr. Water Manag. Waste Water Treat. RIZA, Lelystad, pp. 16–17.
- Held, I.M., 2013. The cause of the pause. *Nature* 501, 318–319.
- Henderson, P.A., 2007. Discrete and continuous change in the fish community of the Bristol channel in response to climate change. *J. Mar. Biol. Assoc. UK* 87, 589–598. doi:10.1017/S0025315407052447
- Henderson, P.A., Seaby, R.M., 2005. The role of climate in determining the temporal variation in abundance, recruitment and growth of sole *Solea solea* in the Bristol channel. *J. Mar. Biol. Assoc. UK* 85, 197–204. doi:10.1017/S0025315405011069h

-
- Henriques, M., Gonçalves, E., Almada, V., 2007. Rapid shifts in a marine fish assemblage follow fluctuations in winter sea conditions. *Mar. Ecol. Prog. Ser.* 340, 259–270. doi:10.3354/meps340259
- Herrmann, J.P., Jansen, S., Temming, A., 1998. Fish and decapod crustaceans in the Sylt-Rømø bight, in: Gätje, C., Reise, K. (Eds.), *Ökosystem Wattenmeer - Austausch-, Transport- Und Stoffumwandlungsprozesse*. Springer, Berlin, Heidelberg, New York, pp. 81–88.
- Herrmann, J.P., Jansen, S., Temming, A., 1998. Consumption of fish and decapod crustaceans and their role in the trophic relations of the Sylt-Rømø bight, in: Gätje, C., Reise, K. (Eds.), *Ökosystem Wattenmeer-Austausch-Transport- Und Stoffumwandlungsprozesse*. Springer, Berlin-Heidelberg, pp. 437–462.
- Hinz, V., 1989. Monitoring the fish fauna in the Wadden Sea with special reference to different fishing methods and effects of wind and light on catches. *Helgol. Mar. Res.* 43, 447–459.
- Jager, Z., Bolle, L., Dänhardt, A., Diederichs, B., Neudecker, T., Scholle, J., Vorberg, R., 2009. Thematic Report No. 14, in: Marencic, H., Vlas de, J. (Eds.), *Wadden Sea Quality Status Report (QSR) 2009*. Trilateral Monitoring and Assessment Group (TMAG) Common Wadden Sea Secretariat, Wilhelmshaven, pp. 1–42.
- Jager, Z., Bolle, L., Dänhardt, A., Diederichs, B., Neudecker, T., Scholle, J., Vorberg, R., Vorberg, R., 2009. *Wadden Sea Ecosystem No. 25 Quality Status Report 2009 Thematic Report No. 4*.
- Jepsen, N., Deacon, M., Koed, A., 2012. Decline of the North Sea houting: protective measures for an endangered anadromous fish. *Endanger. Species Res.* 16, 77–84. doi:10.3354/esr00386
- Kanstinger, P., Peck, M.A., 2009. Co-occurrence of European sardine (*Sardina pilchardus*), anchovy (*Engraulis encrasicolus*) and sprat (*Sprattus sprattus*) larvae in southern North Sea habitats: abundance, distribution and biochemical-based condition. *Sci. Mar.* 73, 141–152. doi:10.3989/scimar.2009.73s1141
- Kellnreitner, F., Pockberger, M., Asmus, H., 2012. Seasonal variation of assemblage and feeding guild structure of fish species in a boreal tidal basin. *Estuar. Coast. Shelf Sci.* 108, 97–108. doi:10.1016/j.ecss.2011.02.020
- Kerby, T.K., Cheung, W.W.L., van Oosterhout, C., Engelhard, G.H., 2013. Entering uncharted waters: Long-term dynamics of two data limited fish species, turbot and brill, in the North Sea. *J. Sea Res.* 84, 87–95. doi:10.1016/j.seares.2013.07.005
- Kosaka, Y., Xie, S.-P., 2013. Recent global-warming hiatus tied to equatorial Pacific surface cooling. *Nature* 501, 403–7. doi:10.1038/nature12534

-
- MacKenzie, B.R., Köster, F.W., 2004. Fish Production and Climate: Sprat in the Baltic Sea. *Ecology* 85, 784–794.
- Martens, P., 2001. Effects of the severe winter 1995/96 on the biological oceanography of the Sylt-Rømø tidal basin. *Helgol. Mar. Res.* 55, 166–169. doi:10.1007/s101520100078
- Martens, P., Beusekom, van J.E.E., 2008. Zooplankton response to a warmer northern Wadden Sea. *Helgol. Mar. Res.* 62, 67–75. doi:10.1007/s10152-007-0097-0
- Nawratil, M., 2009. Seasonal change of trophic guilds of the fish fauna of the Sylt- Rømø bight (Wadden Sea, Germany). University of Vienna.
- Naylor, R., Hindar, K., Fleming, I., Goldberg, R., Williams, S., Volpe, J., Whoriskey, F., Eagle, J., Kelso, D., Mangel, M., 2005. Fugitive Salmon: assessing the risks of escaped fish from Net-Pen Aquaculture. *Bioscience* 55, 427. doi:10.1641/0006-3568(2005)055[0427:FSATRO]2.0.CO;2
- Nye, J.A., Baker, M.R., Bell, R., Kenny, A., Kilbourne, K.H., Friedland, K.D., Martino, E., Stachura, M.M., van Houtan, K.S., Wood, R., 2013. Ecosystem effects of the Atlantic Multidecadal Oscillation. *J. Mar. Syst.* dx.doi.org, 103–116. doi:10.1016/j.jmarsys.2013.02.006
- Nyitrai, D., Martinho, F., Dolbeth, M., Rito, J., Pardal, M.A., 2013. Effects of local and large-scale climate patterns on estuarine resident fishes: The example of *Pomatoschistus microps* and *Pomatoschistus minutus*. *Estuar. Coast. Shelf Sci.* 135, 260–268. doi:10.1016/j.ecss.2013.10.030
- Ottersen, G., Planque, B., Belgrano, A., Post, E., Reid, P., Stenseth, N., 2001. Ecological effects of the North Atlantic Oscillation. *Oecologia* 128, 1–14. doi:10.1007/s004420100655
- Peet, R.K., 1974. The measurement of species diversity. *Annu. Rev. Ecol. Syst.* 5, 285–307.
- Perry, A.L., Low, P.J., Ellis, J.R., Reynolds, J.D., 2005. Climate change and distribution shifts in marine fishes. *Science* (80-.). 308, 1912. doi:10.1126/science.1111322
- Philippart, C.J., Lindeboom, H., Meer, van der J., Veer, van der H., Witte, J., 1996. Long-term fluctuations in fish recruit abundance in the western Wadden Sea in relation to variation in the marine environment. *ICES J. Mar. Sci.* 53, 1120–1129.
- Pielou, E.C., 1966. Formula as a measure of specific diversity: Its use and misuse. *Am. Nat.* 100, 463–465.
- Polte, P., Asmus, H., 2006. Influence of seagrass beds (*Zostera noltii*) on the species composition of juvenile fishes temporarily visiting the intertidal zone of the Wadden Sea. *J. Sea Res.* 55, 244–252. doi:10.1016/j.seares.2005.11.004

-
- Polte, P., Buschbaum, C., 2008. Native pipefish *Entelurus aequoreus* are promoted by the introduced seaweed *Sargassum muticum* in the northern Wadden Sea, North Sea. *Aquat. Biol.* 3, 11–18. doi:10.3354/ab00071
- Polte, P., Schanz, A., Asmus, H., 2005. The contribution of seagrass beds (*Zostera noltii*) to the function of tidal flats as a juvenile habitat for dominant, mobile epibenthos in the Wadden Sea. *Mar. Biol.* 147, 813–822. doi:10.1007/s00227-005-1583-z
- Pörtner, H., Berdal, B., Blust, R., Brix, O., Colosimo, A., De Wachter, B., Giuliani, A., Johansen, T., Fischer, T., Knust, R., Lannig, G., Nævdal, G., Nedenes, A., Nyhammer, G., Sartoris, F.J., Serendero, I., Sirabella, P., Thorkildsen, S., Zakhartsev, M., 2001. Climate induced temperature effects on growth performance, fecundity and recruitment in marine fish: developing a hypothesis for cause and effect relationships in Atlantic cod (*Gadus morhua*) and common eelpout (*Zoarces viviparus*). *Cont. Shelf Res.* 21, 1975–1997.
- Pörtner, H.O., Knust, R., 2007. Climate change affects marine fishes through the oxygen limitation of thermal tolerance. *Science* (80-.). 95. doi:10.1126/science.1135471
- R Development Core Team, 2013, n.d. R: a language and environment for statistical computing. R Foundation for Statistical Computing, Vienna.
- Raab, K., Nagelkerke, L., Boerée, C., Rijnsdorp, A., Temming, A., Dickey-Collas, M., 2011. Anchovy *Engraulis encrasicolus* diet in the North and Baltic Seas. *J. Sea Res.* 65, 131–140. doi:10.1016/j.seares.2010.09.002
- Reid, P.C., Fatima, M. De, Svendsen, E., 2001. A regime shift in the North Sea circa 1988 linked to changes in the North Sea horse mackerel fishery. *Fish. Res.* 50, 163–171.
- Rogers, J.C., 1984. The association between the North Atlantic Oscillation and the Southern Oscillation in the Northern Hemisphere. *Mon. Weather Rev.* 112, 1999–2015.
- Shannon, C.E., 1948. A Mathematical Theory of Communication. *Bell Syst. Tech. J.* 27, 379–423.
- Simpson, E.H., 1949. Measurement of Diversity. *Nature* 163, 688.
- Sims, D.W., Mouth, V.J.W., Genner, M.J., Southward, A.J., Hawkins, S.J., 2004. Low-temperature-driven early spawning migration of a temperate marine fish. *J. Anim. Ecol.* 73, 333–341.
- Solow, A.R., 1993. A simple test for change in community structure. *J. Anim. Ecol.* 62, 191–193.
- Svendsen, E., Aglen, A., Iversen, S., Skagen, D., Smestad, O., 1991. Influence of climate on recruitment and migration of fish stocks in the North Sea. ICES, Pelagic Fish Comm. H:12, 32.

-
- TMAP, 2006. Report of the TMAP ad hoc working group fish, 25 August 2006 [http://www.wadensea-secretariat.or/workshops/TMAP-revision/Fish/TMAP-fish-report-v-5\(06.08.28\).doc](http://www.wadensea-secretariat.or/workshops/TMAP-revision/Fish/TMAP-fish-report-v-5(06.08.28).doc).
- Tulp, I., Bolle, L.J., Rijnsdorp, A.D., 2008. Signals from the shallows: In search of common patterns in long-term trends in Dutch estuarine and coastal fish. *J. Sea Res.* 60, 54–73. doi:10.1016/j.seares.2008.04.004
- Veer, van der H., Koot, J., Aarts, G., Dekker, R., Diderich, W., Freitas, V., Witte, J., 2011. Long-term trends in juvenile flatfish indicate a dramatic reduction in nursery function of the Balgzand intertidal, Dutch Wadden Sea. *Mar. Ecol. Prog. Ser.* 434, 143–154. doi:10.3354/meps09209
- Vorberg, R., Bolle, L., Jager, Z., Neudecker, T., 2005. Wadden Sea Ecosystem No. 19, in: Essink, K., Dettmann, C., Farke, H., Laursen, K., Lüerßen, G., Marencic, H., Wiersinga, W. (Eds.), *Wadden Sea Quality Status Report (QSR) 2004*. Trilateral Monitoring and Assessment Group, Common Wadden Sea Secretariat, Wilhelmshaven, pp. 219–236.
- Vorberg, R., Breckling, P., 1999. Atlas der Fische im Schleswig-Holsteinischen Wattenmeer. *Schriftenr. des Natl. Schleswig-Holsteinisches Wattenmeer* 10, 178.
- Walker, G.T., Bliss, E.W., 1932. World weather. V. *Mem. Roy. Meteor. Soc.* 4, 53–84.
- Wallace, J.M., Gutzler, D.S., 1981. Teleconnections in the geopotential height field during the Northern Hemisphere Winter. *Mon. Weather Rev.* 109, 784–812.
- Weijerman, M., Lindeboom, H., Zuur, A.F., 2005. Regime shifts in marine ecosystems of the North Sea and Wadden Sea. *Mar. Ecol. Prog. Ser.* 298, 21–39.
- Westernhagen von, H., 1993. Mögliche klimabedingte Beeinflussung der Nordsee-Ichthyofauna, in: Schellnhuber, H.J., Sterr, H. (Eds.), *Klimaänderung Und Küste*. Springer, Berlin, Heidelberg, pp. 212–222.
- Witte, J.Y., Zijlstra, J.J., 1978. The species of fish occurring in the Wadden Sea, in: Dankers, N., Wolff, W., Zijlstra, J. (Eds.), *Fishes and Fisheries of the Wadden Sea*. Balkema, AA, Rotterdam: 10-25., pp. 10–25.
- Wolff, W.J., 2013. Ecology of the Wadden Sea: Research in the past and challenges for the future. *J. Sea Res.* 82, 3–9. doi:10.1016/j.seares.2013.03.006
- Yang, J., 1982. The dominant fish fauna in the North Sea and its determination. *J. Fish Biol.* 20, 635–643.
- Zijlstra, J.J., 1972. On the importance of the Wadden Sea as a nursery area in relation to the conservation of the southern North Sea fishery resources, in: *Symp. Zool. Soc. Lond.* pp. 233–258.

CHAPTER II. AN ABUNDANT SMALL SIZED FISH AS KEYSTONE SPECIES? THE EFFECT OF *POMATOSCHITUS MICROPS* ON FOOD WEBS AND ITS TROPHIC ROLE IN TWO INTERTIDAL BENTHIC COMMUNITIES: A MODELING APPROACH

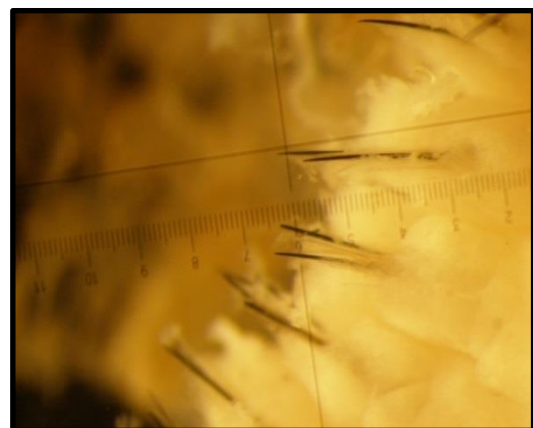
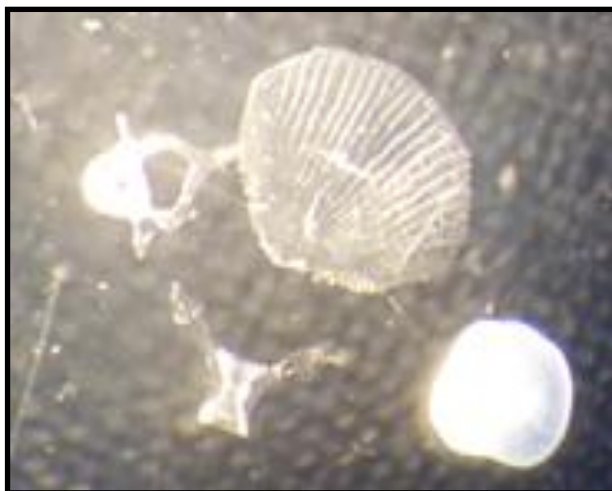

Pictures p. 85 Predator and leftovers of prey items found in stomachs. Top: fish *Pomatoschistus microps* (common goby); Middle left to right: carapace leftovers of *Crangon crangon* (brown shrimp), body parts of polychaete (bristle worm); Bottom left to right: vertebrae, scale and otolith of digested fish, detailed picture of acicula and chaeta of polychaete.

Source and copyright: Florian Kellnreitner, Moritz Pockberger

CHAPTER II. AN ABUNDANT SMALL SIZED FISH AS KEYSTONE SPECIES? THE EFFECT OF *POMATOSCHITUS MICROPS* ON FOOD WEBS AND ITS TROPHIC ROLE IN TWO INTERTIDAL BENTHIC COMMUNITIES: A MODELING APPROACH

Moritz Pockberger^{1, 2*}, Florian Kellnreitner^{1, 2}, Harald Ahnelt², Ragnhild Asmus¹, Harald Asmus¹

¹ Alfred Wegener Institute for Polar and Marine Research, Wadden Sea Station Sylt, Hafenstrasse 43, D-25992 List, Germany

² University of Vienna, Department of Theoretical Biology, Althanstrasse 19, A-1090 Vienna, Austria

* corresponding author: moritz.pockberger@awi.de

Abstract

Ecological network analysis (ENA) was used to study the effects of *P. microps* on energy transport through the food web, its impact on other compartments and its possible role as a keystone species in the trophic webs of an *Arenicola* tidal flat ecosystem and a sparse *Zostera noltii* bed ecosystem. Three ENA models were constructed: (a) model 1 contains data of the original food web from prior research, (b) an updated model 2 which includes biomass and diet data of *P. microps* from recent sampling, and (c) model 3 simulating a food web without *P. microps*. A comparison of energy transport between the different models revealed that more energy is transported in the presence of *P. microps* (model 1 and 2) than in its absence (model 3). Furthermore an increased carbon transport up the food chain could be shown in the presence of *P. microps*. Calculations of the index of keystones (KSi) revealed the high overall impact (measured as ϵ_i) of this fish species on food webs. In model 1, *P. microps* was ranked at position 18 in the *Arenicola* flat (KSi - 0.46, ϵ_i 0.27) and at position 4 in the sparse *Z. noltii* bed (KSi - 0.08, ϵ_i 0.9). Calculations in model 2 ranked *P. microps* first for keystones and ϵ_i in both communities the *Arenicola* flat (KSi 0.26, ϵ_i 1) and the sparse *Z. noltii* bed (KSi 0.30, ϵ_i 1). Taken together, our results give insight into the role of *P. microps* when

considering a whole food web and reveal direct and indirect trophic interactions of this small-sized fish species.

Key words

Pomatoschistus microps, Food web, Ecological network analysis, keystone, Seagrass, Wadden Sea, ECOPATH with ECOSIM, NETWRK 4.2a

1. Introduction

The common goby *Pomatoschistus microps* occurs in intertidal near shore areas, estuaries, lagoons, and brackish waters along the Atlantic coast from Norway to Morocco, in the North Sea including the Wadden Sea, in the Baltic Sea, and in the western part of the Mediterranean Sea (Miller, 2004, 1975; Vorberg and Breckling, 1999). It is a short-lived species (up to two years) and reaches a maximal total length of 64 mm (Ahnelt, 1991; Miller, 2004, 1986). As an omnivorous, opportunistic fish species (e.g. Polte et al., 2005), it feeds on as many as sixty different prey species including meiofauna, small crustaceans, polychaetes, bivalvia, insects and even small teleosts (Zander and Hartwig, 1982; Pihl, 1985; Norte-Campos and Temming, 1994; Leitão et al., 2006; Kellnreitner, 2012). Small-sized fish species such as *P. microps* are an important prey for larger predators and thus exert a bottom up control for higher trophic levels (Moore and Moore, 1976; Behrends, 1985; Ntiba and Harding, 1993; Hall et al., 1998; Kubetzki and Garthe, 2003; Dänhardt et al., 2010). Although small sized, common gobies are themselves predators and by their often high abundances can exert top down control on population growth of their prey (Maes et al., 2003; Pihl and Rosenberg, 1982; Zander and Hartwig, 1982). Because of their middle trophic position within the food web, they can have an impact on population size of species in lower and higher trophic levels and thus create a “wasp-waist” flow control (Coll and Libralato, 2012; Cury,

2000) when they are the dominant component on that particular trophic level. Additionally, small-sized fish species are important competitors for other species feeding on the same resource (Magnhagen and Wiederholm, 1982; Pihl, 1985; Norte-Campos and Temming, 1994; Norte-Campos, 1995). Therefore, if abundant, they are potentially important components of ecosystems and may fulfill the role of a keystone species (Coll and Libralato, 2012).

The concept of keystone species was formulated by Paine (1969) and later adapted by Power et al. (1996) who defined a keystone species as having a large impact on its community, compared to its relative low abundance and biomass. Davic (2003) proposed an alternative definition: “Any species identified *a priori* as biomass-dominant within its occupied functional group should be recognised as a potential keystone species”. Coll and Libralato (2012) suggested a further definition of “keystones” that considered abundant species and their high overall impact on a system. Although the common goby is not commercially exploited, it may play an important role in food webs and in energy flow within and between ecosystems due to its high abundance (Miller, 2004, 1986, 1975; Polte et al., 2005) and broad diet spectrum (Ehrenberg et al., 2005; Evans, 1984; Herrmann et al., 1998). While feeding activity and diet of *P. microps* have been intensively studied, the analysis of empirical data by ecological network analysis (ENA) to investigate the effects of a small-sized fish species presence/absence considering a whole food web has not yet been done.

We hypothesise that more energy is transported up the food chain in the presence of *P. microps* than in its absence, as this species feeds intensively on lower trophic levels and serves as an energy source for higher trophic levels. We tested this for two different benthic communities, an *Arenicola* sandflat (representing the largest community in the study area) and a sparse seagrass bed (forming the largest continuous intertidal plant canopies in the

Sylt-Rømø Bight (SRB) within the German North Sea. Given the high abundance and the broad diet spectrum of *P. microps*, we expect to find a high overall impact of this species in the investigated tidal areas, and accordingly, a high index of keystones (KSi).

Specifically, our study aims to investigate the influence of the common goby on energy flow and trophic interactions using empirical data analysed by the routines of ENA. A second aim is to calculate the impact of *P. microps* on other taxa within the food web. Finally, the keystones of this abundant and small-sized species in intertidal food webs is investigated and discussed.

2. Materials & Methods

2.1. Study site

The SRB (54° 52' - 55° 10'N, 8° 20' - 8° 40'E) is a part of the Wadden Sea, which extends along the coast of the southeastern North Sea reaching from the Netherlands to Denmark. The bight itself is situated between the islands of Sylt (Germany) and Rømø (Denmark) and comprises an area of 404 km², including 135 km² of tidal flats (Asmus and Asmus, 2000). The tidal range inside the bight is up to 2 m and salinity ranges between 24 and 32 (Martens and Beusekom, 2008). Two causeways connecting the islands with the mainland inhibit the movement of water around the islands and direct exchange with adjacent tidal basins. Between the islands there is only one tidal inlet of 2 km width and 40 m depth (Bayerl and Köster, 1998). A detailed description of the SRB is given in Gätje and Reise (1998). For a detailed description of the *Arenicola* flat and the sparse *Z. noltii* bed used in this study see (Baird et al., 2007).

2.2. Sampling procedures

Pomatoschistus microps was sampled monthly on a randomly chosen location in an *Arenicola* flat and a sparse *Z. noltii* bed using a beach seine, from August until December 2006 and September 2008 until May 2009. The net was 12 m long and 2.50 m high, with a mesh size of 6 mm in the wings and 4 mm in the cod end. To obtain biomass and size data, all individuals were counted, weighted (to the nearest 0.001g) and measured (total length to the nearest 0.1 mm), bigger catches were subsampled. For gut content analyses, total length (TL) of randomly subsampled fish was measured and specimens were separated into 10 mm size classes. In total, contents of 180 whole digestive tracts of *P. microps* (21.7 to 58.7 mm TL) were analysed. Prey taxa were identified to the lowest possible taxonomic unit.

2.3. Data processing

Food web models constructed by Baird et al. (2007) for *Arenicola* flat and sparse *Z. noltii* bed were compared with those constructed for this study which included recently measured biomass and consumption of *P. microps*. Food web models were constructed with 56 living and 3 non-living compartments. Models were based on biomass, imports, exports, respiration and the flow of carbon ($\text{mg C m}^{-2} \text{ day}^{-1}$) between the compartments using ENA (NETWRK 4.2a). To standardise our data so that it could be compared to that of Baird et al. (2007), it was necessary to determine the gut contents of *P. microps* in dry and ash weight to the nearest 0.001 g per prey item. Gut contents were dried for 5 days at 50°C and subsequently combusted at 500°C for 5 hours. Ash free dry weight (AFDW) was calculated and converted into carbon units (Heerkloss and Vietinghoff, 1981; Herrmann et al., 1998). Carbon contents were obtained from the literature for certain prey taxa e.g. copepods that were not species-specific (Hickel, 1975), harpacticoid copepods (Hickel, 1975), cypris larvae

(Lucas et al., 1979), Foraminifera and Ostracoda (Widbom, 1984). Mean individual weight of every prey component was calculated. Consumption was estimated after (Winberg, 1956). Respiration rates (Eq. 1) were computed for different size classes of *P. microps* and different temperatures using coefficients after (Fonds and Veldhuis, 1973).

$$R = e^{a \cdot T} * k * W^b \quad (1)$$

Where R = respiration, temperature dependent coefficient $a = 0.1$ (Ege and Krogh, 1914), T = temperature in °C, k and b are temperature dependent coefficients given by (Fonds and Veldhuis, 1973) and W = the wet weight in g of individuals.

Production (Winberg, 1956; Norte-Campos, 1995) was estimated by calculating the increase of weight per day (Eq. 2)

$$\Delta B = [10^{d^{-1}} * (\log W_{t2} - \log W_{t1})] * 100 \quad (2)$$

Where ΔB gives the daily increase of weight in percent, d gives the time interval in days, (W_{t2} the weight after 1 day - W_{t1} starting weight). Increase in weight was estimated by converting daily growth rate of 0.25 mm (Norte-Campos, 1995) to weight units on the basis of current empirical length-weight relationships (Eq. 3).

$$W = 1.2751 * 10^{-6} * L^{3.5037} \quad (3)$$

Where L gives the total length in mm.

Consumption rates were calculated in $\text{mg C m}^{-2} \text{ d}^{-1}$ (Heerkloss and Vietinghoff, 1981) taking into account different size classes and abundances of every sampling month (Eq. 4).

$$C = 1 * A^{-1} (\Delta B + R) \quad (4)$$

where C = consumption, A = the absorption coefficient of 0.8 (Herrmann et al., 1998; Winberg, 1956).

To calculate the consumption of each ingested prey item the relative proportion of the particular prey item on the total consumption was estimated. Finally, the monthly consumption rates of each ingested prey species considering different size classes were summed up and the arithmetic mean was calculated for the total sampling period. Consumption rates of *P. microps* per month are given in Supplement 1.

2.4. Network analysis

Lindeman spine

A Lindeman spine is a concatenated form of a food web, transforming a complex network of trophic transfers into a linear food chain with discrete trophic levels. It shows the imports, exports, respiration, amount of energy passed to the next level, and the returns to the detrital pool of each trophic level. Furthermore, the efficiency of energy transferred in a system is illustrated (Baird et al., 2004; Wulff et al., 1989) Trophic efficiency is defined as the difference between input and output of a trophic level in percent (Wulff et al., 1989). Here the Lindeman spine elucidates the possible influence of *P. microps* on trophic interactions and energy transport in the food web of the tidal flat. To construct these simplified food chains the following three models were calculated for an *Arenicola* flat and a sparse *Z. noltii* bed:

-
- I. Model 1 contained the original data of the food web constructed by Baird et al. (2007).
 - II. In model 2, the biomass and energy budget of *P. microps* was changed to recent values derived from the 2006 – 2009 field sampling program. Due to the more comprehensive analysis of diet and consumption of *P. microps* a few additional compartments were included in the two subsystems. These compartments were zooplankton, *Nereis diversicolor*, *Gammarus spec.*, small crustaceans and *C. crangon* for both communities. Further small polychaetes in the *Arenicola* flat and *Carcinus maenas* in the sparse *Z. noltii* bed. Biomass, consumption, respiration, production and egestion of these additional compartments were taken from networks of other subsystems of the SRB (Baird et al., 2007) and treated as imports. Input data to the networks and to the Lindeman spines are given in Supplement 2.
 - III. Model 3 represents a food web without *P. microps*. This was achieved by removing biomass and trophic interactions of *P. microps* from model 2. It was constructed to illustrate the effect of the absence of *P. microps* on energy transport in the food web. Furthermore it reveals the effect of additional compartments, added in model 2, on energy transport.

Effective trophic position

The effective trophic position (ETP) is a weighted average of trophic steps of a living compartment to the primary producers or non-living compartments (Wulff et al., 1989). The ETP for *P. microps* in model 1 and 2 was calculated using the program NETWRK 4.2a.

Mixed trophic impact

The mixed trophic impact analysis described by (Ulanowicz and Puccia, 1990) gives the impact of biomass change of one compartment on the biomass of other compartments. For example the net impact (q_{ij}) of compartment i on compartment j is calculated (Eq. 5) (Ulanowicz and Puccia, 1990):

$$q_{ij} = g_{ij} - f_{ij} \quad (5)$$

Where g_{ij} = the fraction of compartment j 's diet comprised by compartment i , f_{ij} the fraction of j 's total production that is consumed by compartment i .

The net impact is estimated for the direct and indirect interactions between functional compartments in a food web and displayed in an impact matrix (Ulanowicz and Puccia, 1990). The effect of one compartment on all other compartments in a given food web and the overall effect (ϵ_i), can be calculated from this matrix (Gasalla et al., 2010). Values of the impact matrix, calculated in model 1 and model 2 were used to construct figures which illustrate the positive and negative effects of *P. microps* impacting other compartments and vice versa. For calculations, the routines of the program Ecopath with Ecosim version 6 (EwE) (Christensen et al., 2008) were used.

Keystones Index

To estimate the keystones of *P. microps* in model 1 and model 2, the KSi proposed by Libralato et al. (2006) was calculated using the program EwE (Eq. 6).

$$KSi = \log [\epsilon_i * (1-p_i)] \quad (6)$$

Where ε_i = overall effect of compartment i in the food web calculated by the mixed trophic impact analysis, p_i = the contribution of the biomass of compartment i to the total biomass of the food web.

High values of keystones are calculated for compartments with a low biomass proportion but a high ε_i in a food web. These compartments are ranked according to ε_i , (a value of 1 being highest) closer to 1 and with highest values of KSi (Gasalla et al., 2010; Libralato et al., 2006). All calculations and food web models were calculated mass-balanced.

3. Results

3.1. Trophic structure

Whereas model 1 revealed that mainly meiobenthos and different polychaetes were consumed, our analyses of digestive tract contents used to calculate model 2 showed a broad spectrum of prey items from various compartments (Table 1).

Table 1. Compartment names in alphabetical order (bold characters used for network analysis and their properties, standard characters used for model 1 and model 2 in *Arenicola* flat and sparse *Zostera noltii* (*Z. noltii*) bed. Values indicate consumption of compartments by *Pomatoschistus microps* in mg carbon m⁻² day⁻¹. + indicates prey item found, - indicates prey item not found in the diet of *P. microps*.

Compartment name properties	Model 1 <i>Arenicola</i> flat	Model 2 <i>Arenicola</i> flat	Model 1 sparse <i>Z. noltii</i> bed	Model 2 sparse <i>Z. noltii</i> bed
<i>Arenicola marina</i>	-	1.87	-	0.66
Bivalvia n.d.	-	0.22	-	-
Capitellidae n.d.	-	-	0.31	-
<i>Carcinus maenas</i>	-	0.78	-	0.29
<i>Crangon crangon</i>	-	3.52	-	2.38
<i>Gammarus locusta</i>	0.03	-	-	-
<i>Gammarus spec.</i>	-	0.76	-	0.56
Meiobenthos	0.15	0.62	2.32	1.17
Copepoda harpacticoid	-	+	-	+
Copepoda n.d.	-	+	-	+
Foraminifera	-	+	-	+
Ostracoda	-	+	-	+
<i>Nephtys sp.</i>	-	1.20	-	-
Nereidae n.d.	-	7.48	-	-
<i>Hediste diversicolor</i>	+	+	+	-
<i>Nereis sp.</i>	-	+	-	-
Oligochaeta	-	-	0.31	-

<i>Pygospio elegans</i>	0.04	-	-	-
<i>Scoloplos armiger</i>	0.12	-	0.15	-
Small polychaetes	0.06	2.82	-	0.52
<i>Eteone longa</i>	+	-	+	-
<i>Eteone picta</i>	-	+	-	+
<i>Malacoceros</i> sp.	+	-	+	-
Pectinariidae n.d.	-	+	-	+
Polycheata n.d.	-	+	-	+
<i>Scolelepis foliosa</i>	+	-	+	-
<i>Sphaerosyllis hystrix</i>	-	+	-	+
<i>Spio filicornis</i>	+	-	+	-
Small crustacea	-	10.31	-	12.09
Amphipoda n.d.	-	+	-	+
Cumaceasum n.d.	-	+	-	+
Decapoda n.d.	-	+	-	+
Hyalidae n.d.	-	+	-	+
Isopoda n.d.	-	+	-	+
<i>Leptomysis arenosa</i>	-	+	-	+
<i>Microprotus maculatus</i>	-	+	-	+
Mysidacea n.d.	-	+	-	+
Nebalidae n.d.	-	+	-	+
<i>Paramysis arenosa</i>	-	+	-	+
<i>Praunus</i> sp.	-	+	-	+
Zooplankton	-	0.59	-	1.09
Cypris larvae	-	+	-	+
Polychaeta larvae	-	+	-	+

Model 1 indicated major feeding activities on one level, whilst model 2 showed a more balanced feeding activity on various trophic levels. In model 1, the feeding activity of *P. microps* was calculated to be 81% at trophic level 3 for the *Arenicola* flat and 87.8% at trophic level 3 for the sparse *Z. noltii* bed. Feeding occurred at trophic level 4 up to 18.4% in the *Arenicola* flat and 12.2% in the sparse *Z. noltii* bed. At higher trophic levels, feeding activity of *P. microps* was below 1%. The average trophic level of *P. microps* in model 1 was calculated at 3.20 in the *Arenicola* flat and 3.12 in the sparse *Z. noltii* bed (Table 2).

In model 2 for the *Arenicola* flat, feeding activity at trophic level 3 was 56.5%, followed by levels 4 with 39.3% and 5 with 4%. For the sparse *Z. noltii* bed, calculations gave 67% feeding at trophic level 3, a further 30.1% at level 4 and 2.7% at level 5. Overall, this led to a higher average trophic level of *P. microps* in model 2 for the *Arenicola* flat (3.48) and for the sparse *Z. noltii* bed (3.36) (Table 2).

Table 2. Values indicate the feeding activity in % of *Pomatoschistus microps* in different trophic levels of the food web and the effective trophic position (ETP) calculated as the weighted average of feeding activity.

Trophic level	Model 1	Model 2	Model 1	Model 2
	<i>Arenicola</i> flat Feeding activity(%)	<i>Arenicola</i> flat Feeding activity(%)	sparse <i>Z. noltii</i> bed Feeding activity(%)	sparse <i>Z. noltii</i> bed Feeding activity(%)
1	-	-	-	-
2	-	-	-	-
3	81.00	56.50	87.80	67.00
4	18.40	39.30	12.20	30.10
5	0.55	4.06	-	2.77
6	>0.01	0.14	-	0.09
7	-	>0.01	-	>0.01
ETP	3.20	3.48	3.12	3.36

3.2. Energy transport and impact on food webs

Our Lindeman spines show that trophic efficiencies and energy transport through the food chain are higher when *P. microps* is present in the food web. Model 1 showed that energy is transported up to the 6th and the 5th for the *Arenicola* flat (Fig. 1) and the sparse *Z. noltii* bed (Fig. 2), respectively. Beyond level 3, trophic efficiencies do not exceed 1%. Lindeman spines of model 2 show an increased energy transport compared to models 1 and 3. In model 2, energy is transported up to trophic levels 7 in the *Arenicola* flat and 8 in the sparse *Z. noltii* bed. Values of trophic efficiencies below 1% were only found between the highest trophic levels in the sparse *Z. noltii* bed. Lindeman spines constructed for model 3 (in which *P. microps* were artificially removed) gave higher values for energy transport and trophic efficiencies than model 1, but lower values than model 2.

The mixed trophic impact analysis revealed the direct and indirect impacts of *P. microps* on other compartments and vice versa for model 1 (relatively low abundance of *P. microps*) and model 2 (relatively high abundance of *P. microps*).

P. microps as an impacting compartment:

Analyses of model 1 gave lower impact values of *P. microps* on fewer compartments compared to model 2 (Fig. 3). Impact values calculated in model 1 for an *Arenicola* flat ranged between -0.18 and 0.06, and between -0.49 and 0.04 for a sparse *Z. noltii* bed (Fig. 3). Impact values for model 2 were between -0.79 and 0.53 and -0.79 and 0.56 for an *Arenicola* flat and a sparse *Z. noltii* bed, respectively (Fig. 3). In the *Arenicola* flat no negative impact stronger than -0.20 could be detected in model 1, while for model 2, nine such distinct effects could be recorded (Fig. 3). These effects were mainly related to species directly consumed by *P. microps*, such as *C. maenas*, *C. crangon*, Zooplankton, *N. diversicolor*, *Gammarus spec.*, *Arenicola marina* and small polychaetes. Indirect negative effects were due to interspecific (*Merlangius merlangus*) and intraspecific competition.

In the *Z. noltii* bed, only six compartments were impacted negatively, exceeding an impact value of -0.20 in model 1. However, in model 2, ten negatively impacted compartments could be detected. In both models Capitellidae, Oligochaeta and *Scoloplos armiger* were directly and negatively impacted by *P. microps* due to predation. In model 1, meiobenthos also contributed to this group, and in model 2 *C. crangon*, zooplankton, *Gammarus spec.*, *Nereis diversicolor*, small crustaceans and *Arenicola marina* contributed additionally to this group.

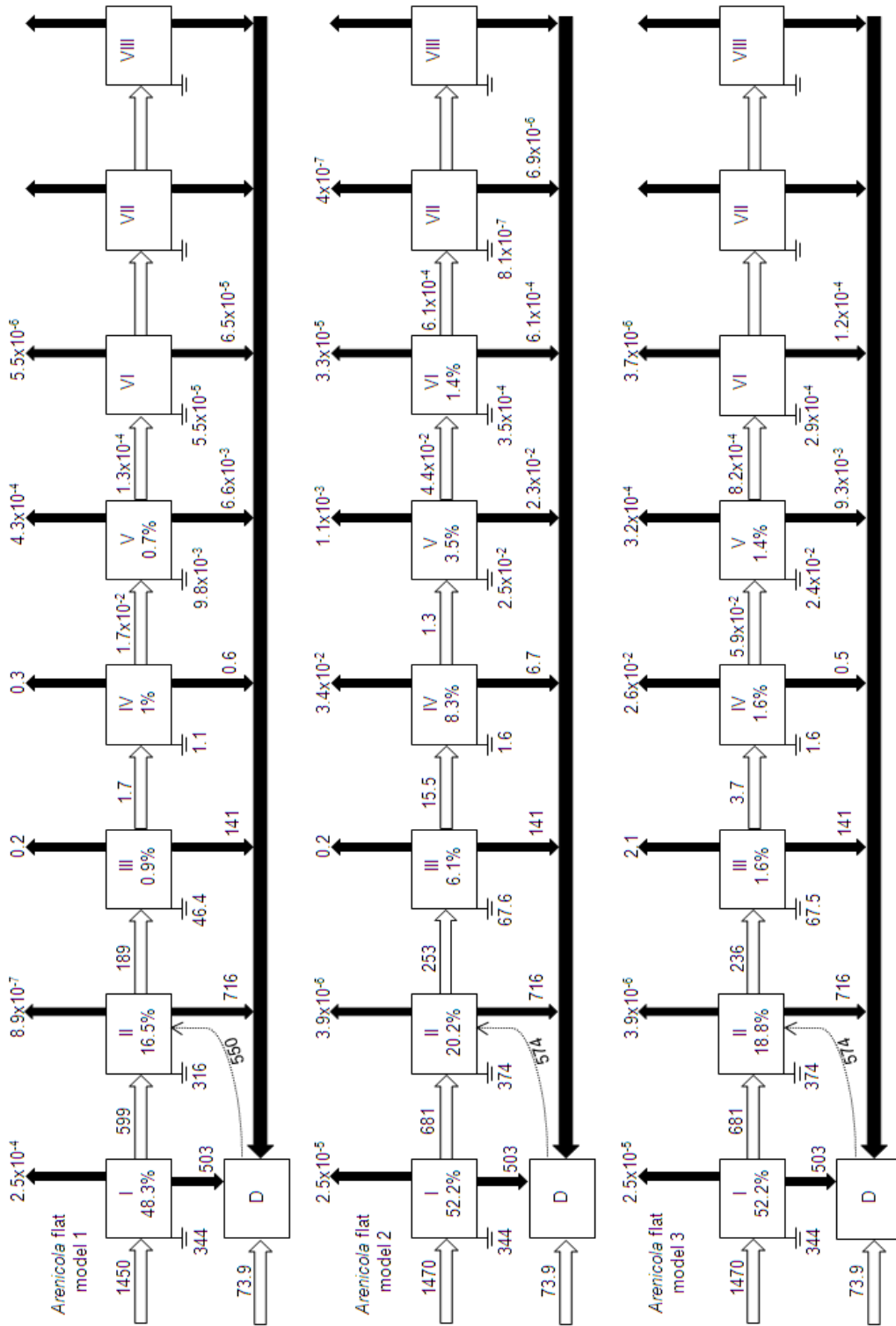

Fig. 1. Lindeman spines for Arenicola flat of model 1: contains data of the food web constructed by Baird et al. (2007). Model 2: biomass and diet of *Pomatoschistus microps* is exchanged according to field samplings and gut content analysis. Model 3: biomass of *P. microps* and trophic interactions between *P. microps* and other compartments are removed, representing a food web without *P. microps*

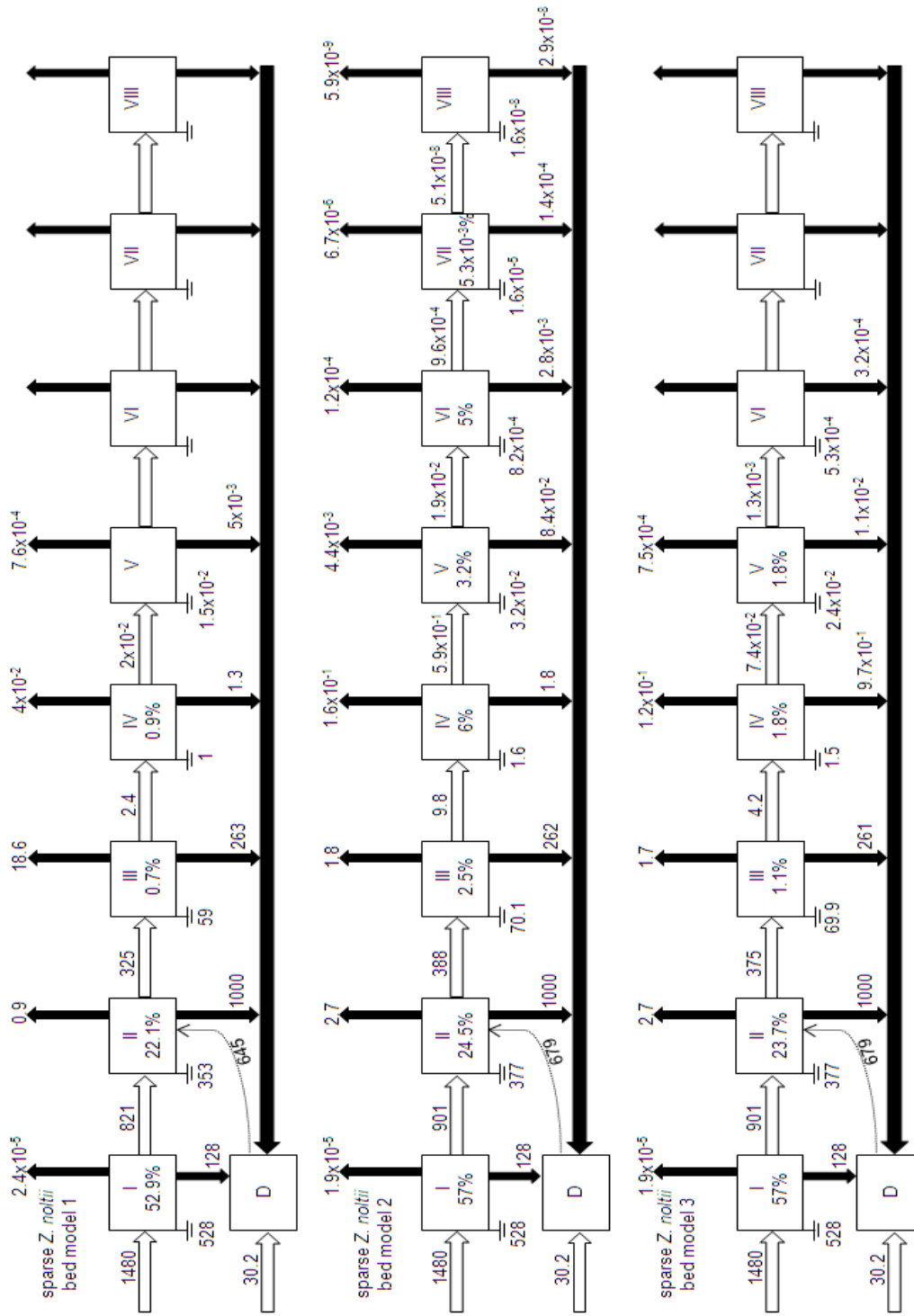

Fig. 2. Lindeman spines for sparse *Zostera noltii* (*Z. noltii*) bed of model 1: contains data of the food web constructed by Baird et al. (2007). Model 2: biomass and diet of *Pomatoschistus microps* is exchanged according to field samplings and gut content analysis. Model 3: biomass of *P. microps* and trophic interactions between *P. microps* and other compartments are removed, representing a food web without *P. microps*.

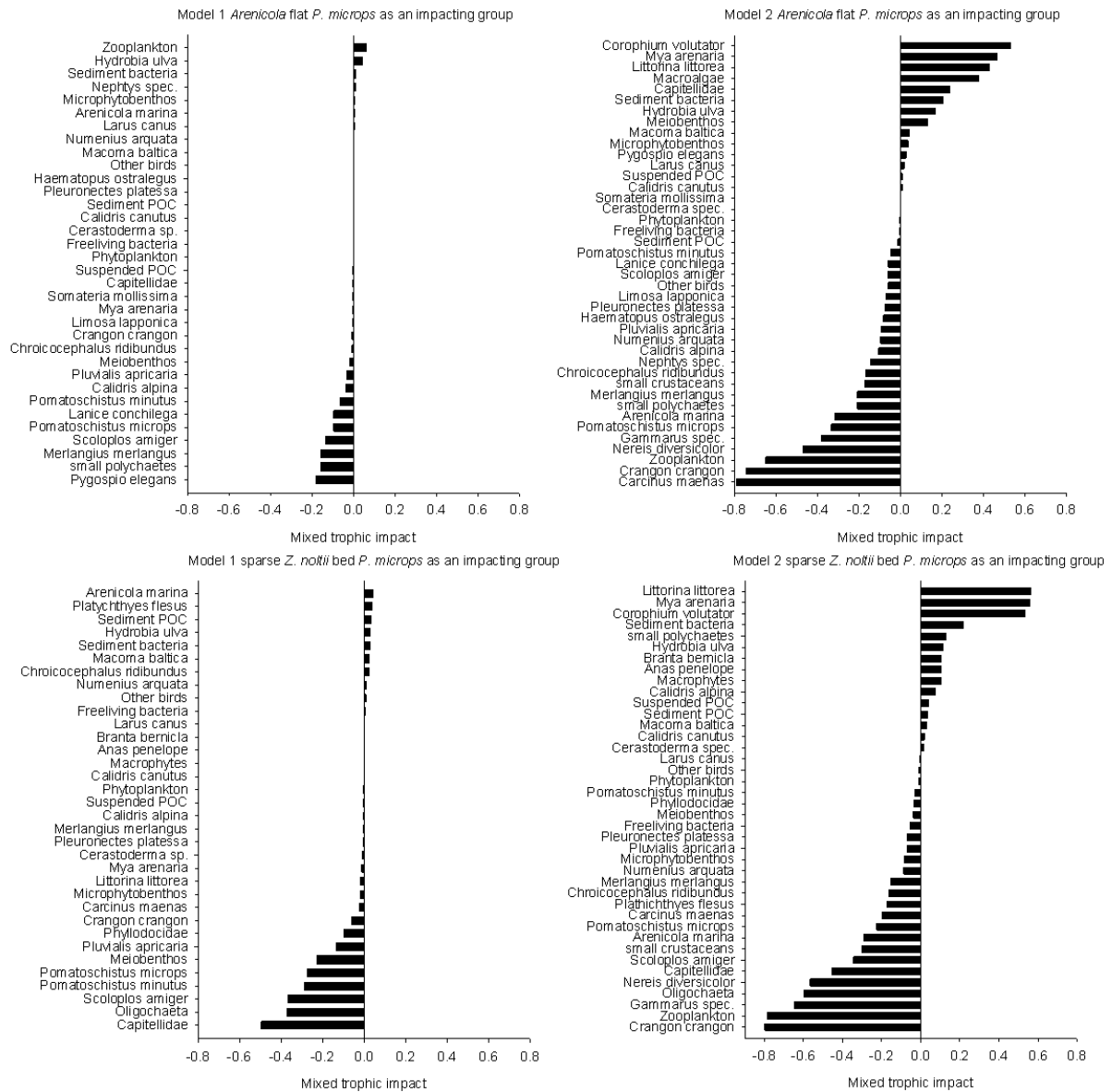

Fig 3. Mixed trophic impact of *Pomatoschistus microps* as an impacting compartment illustrated for model 1 and model 2 in *Arenicola* flat and sparse *Zostera noltii* (*Z. noltii*) bed.

P. microps as an impacted compartment:

In both models 1 and 2 *P. microps* seems to be positively influenced via direct and indirect effects. In the *Arenicola* flat, prey compartments such as *Scoloplos armiger* and meiobenthos exerted direct effects stronger than 0.20 on *P. microps* in model 1. In model 2, small crustaceans and other prey components like small polychaetes and *Crangon crangon* influenced *P. microps* positively (Fig. 4). These prey groups were also observed in gut content analyses.

In the seagrass bed, meiobenthos (directly used as a food resource) and sediment POC (indirectly) influenced *P. microps* positively in model 1, while in model 2 small crustaceans had the strongest positive influence. *Merlangius merlangus* revealed high values of direct negative impact (-0.44) on *P. microps* in model 1 and in model 2 (-0.61), underlining its role as a direct predator on *P. microps* in the seagrass bed. *Carcinus maenas* also was an important predator on *P. microps* (-0.35 in model 1 and -0.34 in model 2) (Fig. 4). Other strong negative impacts were due to intraspecific competition and to indirect effects exerted by the prosobranch *Hydrobia ulvae*.

3.3. Keystones

Keystones indices for *P. microps* were lower in model 1 than in model 2. In model 1, *P. microps* is ranked at position 18 in the *Arenicola* flat (KSi -0.46, ϵ_i 0.27) (Table 3) and at position 4 in the sparse *Z. noltii* bed (KSi -0.08, ϵ_i 0.9) (Table 4). Calculations in model 2 ranked *P. microps* first regarding keystones and ϵ_i , in *Arenicola* flat (KSi 0.26, ϵ_i 1) (Table 3) and sparse *Z. noltii* bed (KSi 0.30, ϵ_i 1) (Table 4) indicating *P. microps* as a keystone species with the highest relative impact on the food web of all compartments.

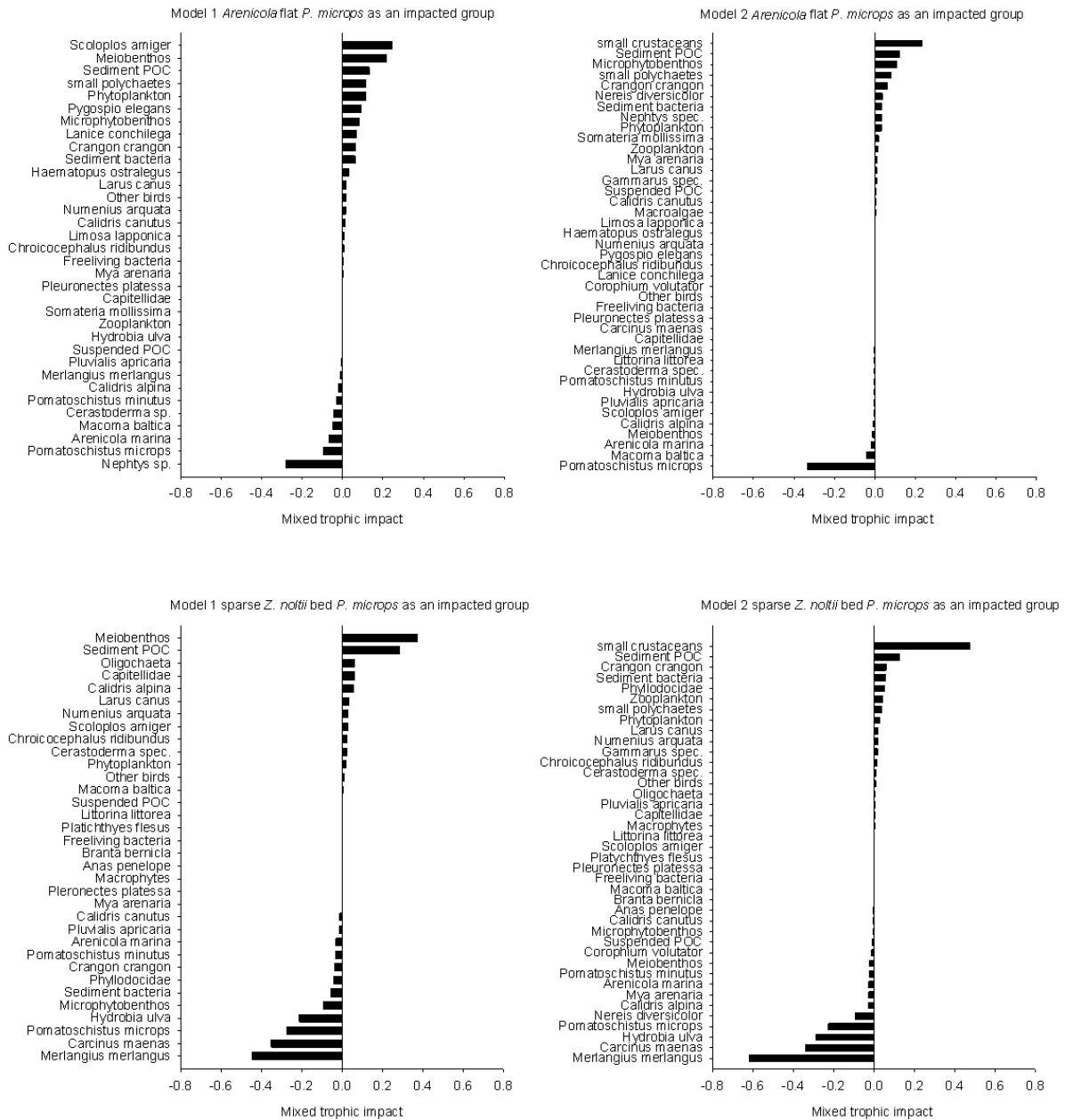

Fig 4. Mixed trophic impact of *Pomatoschistus microps* as an impacted compartment illustrated for model 1 and model 2 in *Arenicola* flat and sparse *Zostera noltii* (*Z. noltii*) bed.

Table 3. Compartments of the *Arenicola* flat food web ranked according to index of keystones (KSi) and overall effect (ϵ_i) in model 1 and model 2.

Model 1 <i>Arenicola</i> flat				Model 2 <i>Arenicola</i> flat			
Rank	Compartment name	KSi	ϵ_i	Rank	Compartment name	KSi	ϵ_i
1	Phytoplankton	0.11	1.00	1	<i>Pomatoschistus microps</i>	0.26	1.00
2	<i>Nephtys</i> sp.	>0.1	0.83	2	Phytoplankton	0.11	0.72
3	Small polychaetes	>0.1	0.69	3	Microphytobenthos	>0.1	0.60
4	<i>Pomatoschistus minutus</i>	-0.05	0.68	4	<i>Nephtys</i> sp.	>0.1	0.61
5	Other birds	-0.06	0.66	5	Small polychaetes	>0.1	0.54
6	<i>Somateria mollissima</i>	-0.12	0.58	6	<i>Nereis diversicolor</i>	>0.1	0.54
7	<i>Macoma baltica</i>	-0.17	0.56	7	<i>Gammarus</i> spec.	-0.08	0.47
8	<i>Crangon crangon</i>	-0.19	0.50	8	<i>Somateria mollissima</i>	-0.14	0.40
9	Microphytobenthos	-0.21	0.48	9	<i>Macoma baltica</i>	-0.16	0.42
10	<i>Arenicola marina</i>	-0.22	0.56	10	<i>Arenicola marina</i>	-0.17	0.44
11	Meiobenthos	-0.22	0.47	11	<i>Cerastoderma</i> sp.	-0.20	0.65
12	<i>Calidris alpina</i>	-0.23	0.44	12	<i>Calidris alpina</i>	-0.25	0.31
13	<i>Cerastoderma</i> sp.	-0.25	0.92	13	Small crustaceans	-0.28	0.31
14	Sediment bacteria	-0.32	0.38	14	Sediment bacteria	-0.29	0.29
15	<i>Scoloplos amiger</i>	-0.35	0.36	15	Meiobenthos	-0.29	0.29
16	<i>Pluvialis apricaria</i>	-0.42	0.29	16	Macroalgae	-0.33	0.26
17	<i>Haematopus ostralegus</i>	-0.43	0.29	17	<i>Crangon crangon</i>	-0.40	0.22
18	<i>Pomatoschistus microps</i>	-0.46	0.27	18	<i>Pluvialis apricaria</i>	-0.42	0.21
19	<i>Larus canus</i>	-0.68	0.16	19	<i>Scoloplos amiger</i>	-0.44	0.21
20	<i>Limosa lapponica</i>	-0.71	0.15	20	<i>Mya arenaria</i>	-0.54	0.16
21	<i>Chroicocephalus ridibundus</i>	-0.76	0.13	21	<i>Haematopus ostralegus</i>	-0.68	0.12
22	<i>Pygospio elegans</i>	-0.82	0.12	22	<i>Larus canus</i>	-0.68	0.12
23	<i>Calidris canutus</i>	-0.84	0.11	23	<i>Carcinus maenas</i>	-0.74	0.10
24	<i>Lanice conchilega</i>	-0.89	0.10	24	<i>Calidris canutus</i>	-0.85	0.08
25	<i>Numenius arquata</i>	-0.89	0.10	25	<i>Limosa lapponica</i>	-0.92	0.07
26	<i>Hydrobia ulva</i>	-1.00	0.08	26	<i>Pomatoschistus minutus</i>	-0.92	0.07
27	Zooplankton	-1.02	0.07	27	<i>Chroicocephalus ridibundus</i>	-0.94	0.06
28	<i>Mya arenaria</i>	-1.04	0.07	28	Zooplankton	-0.95	0.06
29	<i>Merlangius merlangus</i>	-1.09	0.06	29	<i>Lanice conchilega</i>	-0.97	0.06
30	Freeliving bacteria	-1.83	>0.1	30	<i>Corophium volutator</i>	-0.99	0.06
31	Capitellidae	-2.28	>0.1	31	<i>Hydrobia ulva</i>	-0.99	0.06
32	<i>Pleuronectes platessa</i>	-3.38	>0.1	32	Other birds	-1.00	0.06
				33	<i>Littorina littorea</i>	-1.03	0.05
				34	<i>Pygospio elegans</i>	-1.03	0.05
				35	<i>Numenius arquata</i>	-1.14	>0.1
				36	Freeliving bacteria	-1.86	>0.1
				37	<i>Merlangius merlangus</i>	-2.23	>0.1
				38	Capitellidae	-2.32	>0.1
				39	<i>Pleuronectes platessa</i>	-3.61	>0.1

Table 4. Compartments of the sparse *Zostera noltii* (*Z. noltii*) bed food web ranked according to index of keystones (KSi) and overall effect (ϵ_i) in model 1 and model 2.

Model 1				Model 2			
Rank	sparse <i>Z. noltii</i> bed Compartment name	KSi	ϵ_i	Rank	sparse <i>Z. noltii</i> bed Compartment name	KSi	ϵ_i
1	Microphytobenthos	>0.1	1.00	1	<i>Pomatoschistus microps</i>	0.30	1.00
2	<i>Merlangius merlangus</i>	>0.1	0.99	2	<i>Merlangius merlangus</i>	0.27	0.93
3	<i>Carcinus maenas</i>	-0.05	0.98	3	<i>Carcinus maenas</i>	0.14	0.68
4	<i>Pomatoschistus microps</i>	-0.08	0.90	4	Small crustaceans	0.06	0.60
5	Other birds	-0.09	0.89	5	Phytoplankton	>0.1	0.55
6	<i>Cerastoderma</i> sp.	-0.09	0.99	6	<i>Nereis diversicolor</i>	>0.1	0.55
7	Phytoplankton	-0.10	0.87	7	Microphytobenthos	>0.1	0.48
8	Meiobenthos	-0.11	0.86	8	<i>Hydrobia ulva</i>	-0.07	0.59
9	<i>Calidris alpina</i>	-0.11	0.84	9	<i>Gammarus</i> spec.	-0.08	0.42
10	<i>Arenicola marina</i>	-0.17	0.90	10	<i>Cerastoderma</i> sp.	-0.09	0.44
11	<i>Crangon crangon</i>	-0.20	0.68	11	<i>Calidris alpina</i>	-0.12	0.38
12	<i>Anas penelope</i>	-0.22	0.66	12	<i>Arenicola marina</i>	-0.14	0.43
13	<i>Hydrobia ulva</i>	-0.23	0.96	13	Macrophytes	-0.19	0.42
14	Macrophytes	-0.28	0.77	14	Meiobenthos	-0.23	0.30
15	Sediment bacteria	-0.32	0.53	15	<i>Anas penelope</i>	-0.29	0.26
16	<i>Calidris canutus</i>	-0.40	0.43	16	<i>Crangon crangon</i>	-0.32	0.24
17	<i>Macoma baltica</i>	-0.41	0.43	17	<i>Calidris canutus</i>	-0.36	0.22
18	<i>Pluvialis apricaria</i>	-0.53	0.32	18	Sediment bacteria	-0.36	0.22
19	Phyllodocidae	-0.59	0.28	19	<i>Macoma baltica</i>	-0.39	0.21
20	<i>Numenius arquata</i>	-0.66	0.24	20	<i>Pluvialis apricaria</i>	-0.50	0.16
21	<i>Chroicocephalus ridibundus</i>	-0.68	0.23	21	<i>Mya arenaria</i>	-0.51	0.16
22	Capitellidae	-0.68	0.23	22	Phyllodocidae	-0.51	0.15
23	<i>Larus canus</i>	-0.71	0.21	23	Other birds	-0.54	0.14
24	<i>Scoloplos amiger</i>	-0.72	0.21	24	<i>Larus canus</i>	-0.54	0.14
25	Oligochaeta	-0.82	0.17	25	small polychaetes	-0.63	0.12
26	<i>Branta bernicla</i>	-0.99	0.11	26	<i>Numenius arquata</i>	-0.68	0.10
27	<i>Mya arenaria</i>	-1.03	0.10	27	Capitellidae	-0.70	0.10
28	<i>Pomatoschistus minutus</i>	-1.11	0.08	28	<i>Scoloplos amiger</i>	-0.72	0.10
29	<i>Platichthys flesus</i>	-1.62	>0.1	29	<i>Chroicocephalus ridibundus</i>	-0.73	0.09
30	<i>Littorina littorea</i>	-1.86	>0.1	30	<i>Corophium volutator</i>	-0.88	0.07
31	Freeliving bacteria	-2.04	>0.1	31	Zooplankton	-0.95	0.06
32	<i>Pleuronectes platessa</i>	-3.16	>0.1	32	Oligochaeta	-0.96	0.06
				33	<i>Pomatoschistus minutus</i>	-0.97	0.05
				34	<i>Littorina littorea</i>	-1.03	>0.1
				35	<i>Branta bernicla</i>	-1.06	>0.1
				36	<i>Platichthys flesus</i>	-1.62	>0.1
				37	Freeliving bacteria	-1.97	>0.1
				38	<i>Pleuronectes platessa</i>	-3.17	>0.1

4. Discussion

4.1. Trophic structure

The addition of diet composition to our network analyses for *P. microps* revealed new trophic interactions and allowed a reassessment of its trophic position. The updated trophic

level of the common goby lies between levels 3 and 4, due to its ingestion of zooplankton, small crustaceans and small polychaetes. This result is in accordance with other studies on gut contents of *P. microps* (e.g. Zander and Hartwig, 1982; Evans, 1984; Pihl, 1985; Doornbos and Twisk, 1987; Leitão et al., 2006). Differences in feeding activity and consumption levels between this study and earlier investigations within the SRB (Norte-Campos and Temming 1994; Herrmann et al., 1998b; Baird et al., 2004; Kellnreitner et al., 2012) are likely to the current focus on intertidal communities, the *Arenicola* flat and the seagrass bed i.e. only digestive tracts of fish from these habitats were analysed.

4.2. Energy transport and impact on food webs

Alterations to the food web depending on our different models are illustrated by the Lindeman spines. Specifically, the import of additional compartments ingested by *P. microps* into model 2 resulted in higher energy transport and higher trophic efficiencies compared to model 1. The import of these additional compartments from other subsystems represents the passive or active migration of certain compartments between different subsystems. Species in intertidal areas are rarely restricted to one subsystem as they are influenced by the tidal cycle and seasonal changes or are swirled up and drifted from the sediment by strong currents and wave action resulting in lateral energy transfer between habitats (Armonies, 1994, 1989; Baird et al., 2007; Boddeke, 1976; Hampel and Cattrijsse, 2004; Hunter and Naylor, 1993). Nevertheless in the presence of *P. microps* (model 2), more carbon is transported in the food chain resulting in the highest values of trophic efficiencies and energy. High values for energy transport in the presence of *P. microps* are based on its high abundances and intensive feeding on various prey compartments, causing high turnover rates by small benthic fish in intertidal areas (Pihl, 1985; Zander and Hartwig, 1982).

Mixed trophic impact analysis was used to investigate the impact of *P. microps* on other compartments in the food web. This analysis points out direct and especially indirect impacts, which are not readily apparent from empirical data sets on diet composition alone (Ulanowicz and Puccia, 1990). Our results of mixed trophic impact analysis indicate little influence of *P. microps* on higher trophic levels via direct bottom up effects. Here, our results show that *P. microps* effects only a few predator compartments positively. Although *P. microps* is described as an important food and energy resource to other species (Behrends, 1985; Doornbos and Twisk, 1987; Healey, 1972; Pihl and Rosenberg, 1982), only few species feeding on *P. microps* are reported for the SRB (Kellnreitner et al., 2012; Scheiffarth and Nehls, 1997). The lack of positive impacts on predator species in the SRB may be based on the high availability of *C. crangon* as an alternate prey to the same predators. The strongest negative impact on *P. microps* was exerted by the predators *M. merlangus* and *C. maenas* in the seagrass bed. *Merlangius merlangus* is well known as a predator of *P. microps* (Hamerlynck and Hostens, 1994; Herrmann et al., 1998). However, *P. microps* is rarely found in gut contents of *C. maenas* (Ropes, 1968), probably due to its feeding technique of shredding the fish to small pieces before ingestion.

High positive impacts by prey compartments of *P. microps* (e.g. small crustaceans and small polychaetes) reveal direct bottom up effects in our studies food web. Meiobenthos is ingested directly, and indirect bottom up effects derive from sediment bacteria and microphytobenthos that serve as energy resources of compartments ingested by *P. microps*. Interestingly, the negative impacts of *A. marina*, *Nephtys* spec. and *H. ulvae*, on *P. microps* were found to be quite strong. These components are rarely found in digestive tracts of *P. microps* and might cause indirect negative effects via competition for food with prey species of *P. microps*. Our Lindeman spines confirm increasing energy transport in a food web in the

presence of *P. microps*, which was earlier assumed to be prey-predator interactions between single species (Kellnreitner et al., 2012; Scheiffarth and Nehls, 1997). Mixed trophic impact analysis revealed that some energy is passed to higher trophic levels via direct ingestion. However, the main impacts on *P. microps* are through indirect effects, such as intraspecific competition for food. For example, according to Christensen et al. (2008), a compartment can effect itself negatively due to competition for resources. The high intraspecific competition found in our study might be based on the relatively low predation impact on *P. microps* in the SRB.

We derived our results by analysing the studied food web with the ENA method. However, Baird et al. (2009) identify limitations of such a food web model. First the model should represent an energetic steady state condition, which is rarely possible in many studies due to incomplete empirical data for estimations of energy budgets. Second species mainly of lower trophic levels (e.g. bacteria, phytoplankton, microphytobenthos) are assembled into functional compartments due to difficulties of taxonomically identification and measuring energetics of single species. Yet, in spite of the above mentioned limitations, ENA results were derived from highly articulated networks of the SRB ecosystem based on reliable empirical data (Baird et al., 2009).

Calculations of food web models represent interactions between species or compartments, which can be uncovered using ENA considering all dominant compartments of a food web, revealing the strength of direct and especially indirect interactions on a large scale (Heymans et al., 2007; Libralato et al., 2006). Also, certain system indices calculated by ENA can be used to compare ecosystems of different size and geographic location (Christian et al., 2005; Monaco and Ulanowicz, 1997). These indices are also used to assess the status or health of a system (Mageau et al., 1995). A purely experimental approach is mostly restricted to few

species of a food web and thus interactions between species are reduced to those that are selected for the special experiment (Bender et al., 1984; Wootton et al., 1996). An experiment on artificial communities might reveal direct and indirect interactions, but the conclusions on the system level might not be relevant, due to the exclusion of species (Wootton, 1994). Following these arguments the ENA approach provides a useful tool to give insights of direct and indirect interactions of *P. microps* with other compartments in intertidal subsystems and provides a promising technique to integrate empirical and experimental investigations.

4.3. Keystones

The results of our investigation show that, *P. microps* is an important keystone species with a high overall effect on other compartments in *Arenicola* flat and sparse *Z. noltii* bed habitats. Various investigations have focused on the consumption and impact of epibenthic macrofauna on communities. For instance, Reise (1979), Gee et al. (1985) carried out cage experiments, ex- and including common gobies, with both studies observing no significant alteration of prey compartments through ingestion of *P. microps* in enclosed areas. Gee et al. (1985) suggest problems employing cage experiments as a potential explanation for this result: *P. microps* showed a different diet composition than individuals sampled from the outside of cages, due to the exclusion of possible prey items. Also, food competitors of *P. microps*, for example small *C. maenas* and *C. crangon* cannot be excluded from the cages. Finally the tidal feeding rhythm of individuals might have been disturbed due to enclosure in tidal areas. Ehrenberg et al. (2005) estimate consumption of gobies to represent 15-30% of the total benthos production and up to 50-100% of macrofaunal production (excluding bivalvia) in Baltic subtidal systems. High consumption rates are also found in other areas

(Pihl, 1985; Zander and Hartwig, 1982) supporting the high overall effect calculated in this investigation.

Can *P. microps* be defined as a keystone species for the investigated intertidal areas? Keystone species in a food web is not clearly predictable, although compartments of lower trophic levels appear to be important for energy transport in shallow coastal ecosystems (Libralato et al., 2006). Due to its high abundance and accordingly to high biomass the keystone status of *P. microps* seems contradictory to the original definition of a keystone species proposed by Paine (1969) and Power et al. (1996). Coll and Libralato (2012) point out high keystone indices for abundant small pelagic fish due to their high overall impact, suggesting potential problems in the weighting of biomass proportion in the index of keystone species of Libralato et al. (2006), but nevertheless state that the index remains a useful tool to estimate the overall effect. Two types of keystone species might be distinguished using the overall effect (Coll and Libralato, 2012): key compartments with high overall effect but low biomass (Paine 1969, Power et al. 1996) and compartments with high overall effect due to their high biomass (Coll and Libralato, 2012; Piraino et al., 2002). Our results suggest that *P. microps* might be defined as a key species in both investigated communities based on our results for keystone species (KSi values) and its high overall effect due to high biomass. This conclusion should, however, be regarded with care as the definition of a keystone species has become broad (Davic, 2003), and experiments removing *P. microps* from a system on a large scale are missing and seem hard to realise. Nevertheless, our results reveal the high overall impact of the common goby in the food web of the Wadden Sea, resulting in a high-energy uptake from lower trophic levels and an increased transport up the food chain.

5. Conclusion

This ENA investigation shows that energy transport to higher trophic levels is distinctly enhanced in the presence of a dense population of *P. microps*. The mixed trophic impact analysis reveals complex trophic interactions, particularly, a large impact of *P. microps* on lower trophic levels and vice versa. Especially, a dense population of *P. microps* exerts distinct intraspecific competition on itself. Finally, our calculations suggest that *P. microps* is a keystone species in shallow water habitats due to its high biomass and broad diet, resulting in high consumption and hence a high overall impact. Taken together, these results may help to evaluate the importance of *P. microps* and other small-sized omnivore species in food web models and coastal management plans.

Acknowledgments:

The first two authors were partly financed by the Short Research Stays Abroad program (KWA) by the Research Services and International Relations (FSIB) of the University of Vienna. We are grateful to Alfred Resch, Reimer Magens and Paul Walter for technical advice and their experience in designing sampling gear that made sampling procedures much easier. We wish to thank Dan Baird for advice in network analysis and Lisa Shama for improving the manuscript.

References Chapter II

- Ahnelt, H., 1991. Some rare fishes from the Western Mediterranean Sea. *Ann. des Naturhistorischen Museums Wien* 92B, 49–59.
- Armonies, W., 1989. Meiofaunal emergence from intertidal sediment measured in the field: significant contribution to nocturnal planktonic biomass in shallow waters. *Helgol. Mar. Res.* 43, 29–43.
- Armonies, W., 1994. Drifting meio- and macrobenthic invertebrates on tidal flats in Königshafen: a review. *Helgol. Mar. Res.* 320, 299–320.
- Asmus, H., Asmus, R., 2000. Material exchange and food web of seagrass beds in the Sylt-Rømø bight: how significant are community changes at the ecosystem level? *Helgol. Mar. Res.* 54, 137–150.
- Baird, D., Asmus, H., Asmus, R., 2004. Energy flow of a boreal intertidal ecosystem, the Sylt-Rømø bight. *Mar. Ecol. Prog. Ser.* 279, 45–61. doi:10.3354/meps279045
- Baird, D., Asmus, H., Asmus, R., 2007. Trophic dynamics of eight intertidal communities of the Sylt-Rømø bight ecosystem, northern Wadden Sea. *Mar. Ecol. Prog. Ser.* 351, 25–41. doi:10.3354/meps07137
- Baird, D., Fath, B.D., Ulanowicz, R.E., Asmus, H., Asmus, R., 2009. On the consequences of aggregation and balancing of networks on system properties derived from ecological network analysis. *Ecol. Modell.* 220, 3465–3471. doi:10.1016/j.ecolmodel.2009.09.008
- Bayerl, R., Köster, K., 1998. Morphodynamik des Lister Tidebeckens, in: Gätje, C., Reise, K. (Eds.), *Ökosystem Wattenmeer - Austausch-, Transport- Und Stoffumwandlungsprozesse*. Springer, Berlin, Heidelberg, New York, pp. 25–29.
- Behrends, G., 1985. Zur Nahrungswahl von Seehunden (*Phoca vitulina* L.) im Wattenmeer Schleswig-Holsteins. *Zeitschrift für Jagdwissenschaften* 31, 3–14.
- Bender, E.A., Case, T.J., Gilpin, M.E., 1984. Perturbation experiments in community ecology: theory and practice. *Ecology* 65, 1–13.
- Boddeke, R., 1976. The seasonal migration of the brown shrimp *Crangon crangon*. *J. Sea* 10, 103–130.
- Christensen, V., Walters, C.J., Pauly, D., Forrest, R., 2008. *Ecopath with Ecosim version 6 User Guide*. Lensfest Ocean Futures Project 2008.
- Christian, R.R., Baird, D., Luczkovich, J., C, J.J., Scharler, U.M., Ulanowicz, R.E., 2005. Role of network analysis in comparative ecosystem ecology of estuaries, in: Belgrano, A., Scharler, U.M., Dunne, J., Ulanowicz, R.E. (Eds.), *Aquatic Food Webs and Ecosystem Approach*. Oxford University Press, Oxford, pp. 25–40.

-
- Coll, M., Libralato, S., 2012. Contributions of food web modelling to the ecosystem approach to marine resource management in the Mediterranean Sea. *Fish Fish.* 13, 60–88. doi:10.1111/j.1467-2979.2011.00420.x
- Cury, P., 2000. Small pelagics in upwelling systems: patterns of interaction and structural changes in “wasp-waist” ecosystems. *ICES J. Mar. Sci.* 57, 603–618. doi:10.1006/jmsc.2000.0712
- Dänhardt, A., Fresemann, T., Becker, P.H., 2010. To eat or to feed? Prey utilization of common terns *Sterna hirundo* in the Wadden Sea. *J. Ornithol.* 152, 347–357. doi:10.1007/s10336-010-0590-0
- Davic, R.D., 2003. Linking keystone species and functional groups: a new operational definition of the keystone species concept. *Conserv. Ecol.* 7, response 11.
- Doornbos, G., Twisk, F., 1987. Density, growth and annual food consumption of gobiid fish in the saline lake Grevelingen, the Netherlands. *J. Sea Res.* 21, 45–74.
- Ege, R., Krogh, A., 1914. On the relation between the temperature and the respiratory exchange in fishes. *Int. Rev. Hydrobiol.* 1, 48–55.
- Ehrenberg, S., Hansson, S., Elmgren, R., 2005. Sublittoral abundance and food consumption of Baltic gobies. *J. Fish Biol.* 67, 1083–1093. doi:10.1111/j.1095-8649.2005.00811.x
- Evans, S., 1984. Energy budgets and predation impact of dominant epibenthic carnivores on a shallow soft bottom community at the Swedish West Coast. *Estuar. Coast. Shelf Sci.* 18, 651–672.
- Fonds, M., Veldhuis, C., 1973. The oxygen consumption of four *Pomatoschistus* species (Pisces, Gobiidae) in relation to water temperature. *J. Sea Res.* 7, 376–386.
- Gasalla, M.A., Rodrigues, A.R., Postuma, F.A., 2010. The trophic role of the squid *Loligo plei* as a keystone species in the South Brazil Bight ecosystem.
- Gätje, C., Reise, K., 1998. *Ökosystem Wattenmeer - Austausch-, Transport- und Stoffumwandlungsprozesse.* Springer, Berlin, Heidelberg, New York.
- Gee, J.M., Warwick, R.M., Davey, J.T., George, C.L., 1985. Field experiments on the role of epibenthic predators in determining prey densities in an estuarine mudflat. *Estuar. Coast. Shelf Sci.* 21, 429–448. doi:10.1016/0272-7714(85)90022-8
- Hall, A.J., Watkins, J., Hammond, P.S., 1998. Seasonal variation in the diet of harbour seals in the south-western North Sea. *Mar. Ecol. Prog. Ser.* 110, 269–281.
- Hamerlynck, O., Hostens, K., 1994. Changes in the fish fauna of the Oosterschelde estuary - a ten-year time series. *Hydrobiologia* 282/283, 497–507.

-
- Hampel, H., Cattrijsse, A., 2004. Temporal variation in feeding rhythms in a tidal marsh population of the common goby *Pomatoschistus microps* (Kroyer, 1838). *Aquat. Sci.* 66, 315–326. doi:10.1007/s00027-004-0682-0
- Healey, M.C., 1972. On the population ecology of the common goby in the Ythan estuary. *J. Nat. Hist.* 6, 133–145.
- Heerkloss, R., Vietinghoff, U., 1981. Biomasseäquivalente planktischer und benthischer Organismen in den Darß-Zingster Boddengewässern. *Wissenschaftliche Zeitschrift der Univ. Rostock, Math. R.* 31–36.
- Herrmann, J.P., Jansen, S., Temming, A., 1998. Consumption of fish and decapod crustaceans and their role in the trophic relations of the Sylt-Rømø bight, in: Gätje, C., Reise, K. (Eds.), *Ökosystem Wattenmeer-Austausch-Transport- Und Stoffumwandlungsprozesse*. Springer, Berlin-Heidelberg, pp. 437–462.
- Heymans, J.J., Guénette, S., Christensen, V., 2007. Evaluating Network Analysis indicators of ecosystem status in the gulf of Alaska. *Ecosystems* 10, 488–502. doi:10.1007/s10021-007-9034-y
- Hickel, W., 1975. The mesozooplankton in the wadden sea of Sylt (North Sea) 262, 254–262.
- Hunter, E., Naylor, E., 1993. Intertidal migration by the shore crab *Carcinus maenas*. *Mar. Ecol. Prog. Ser.* 101, 131–138. doi:10.3354/meps101131
- Kellnreitner, F., 2012. The trophic structure of a Wadden Sea fish community and its feeding interactions with alien species. Christian-Albrechts-University, Kiel.
- Kellnreitner, F., Pockberger, M., Asmus, H., 2012. Seasonal variation of assemblage and feeding guild structure of fish species in a boreal tidal basin. *Estuar. Coast. Shelf Sci.* 108, 97–108. doi:10.1016/j.ecss.2011.02.020
- Kubetzki, U., Garthe, S., 2003. Distribution, diet and habitat selection by four sympatrically breeding gull species in the south-eastern North Sea. *Mar. Biol.* 143, 199–207. doi:10.1007/s00227-003-1036-5
- Leitão, R., Martinho, F., Neto, J.M., Cabral, H., Marques, J.C., Pardal, M.A., 2006. Feeding ecology, population structure and distribution of *Pomatoschistus microps* (Krøyer, 1838) and *Pomatoschistus minutus* (Pallas, 1770) in a temperate estuary, Portugal. *Estuar. Coast. Shelf Sci.* 66, 231–239. doi:10.1016/j.ecss.2005.08.012
- Libralato, S., Christensen, V., Pauly, D., 2006. A method for identifying keystone species in food web models. *Ecol. Modell.* 195, 153–171. doi:10.1016/j.ecolmodel.2005.11.029
- Lucas, M.I., Walker, G., Holland, D.L., Crisp, D.J., 1979. An energy budget for the free-swimming and metamorphosing larvae of *Balanus balanoides* (Crustacea: Cirripedia). *Mar. Biol.* 55, 221–229. doi:10.1007/BF00396822

-
- Maes, J., Brabandere de, L., Ollevier, F., Mees, J., 2003. The diet and consumption of dominant fish species in the upper Scheldt estuary, Belgium. *J. Mar. Biol. Assoc. UK* 83, 603–612.
- Mageau, M.T., Costanza, R., Ulanowicz, R.E., 1995. The development and initial testing of a quantitative assessment of ecosystem health. *Ecosyst. Heal.* 4, 201–213.
- Magnhagen, C., Wiederholm, A., 1982. Food selectivity versus prey availability: a study using the marine fish *Pomatoschistus microps*. *Oecologia* 55, 311–315.
- Martens, P., Beusekom, van J.E.E., 2008. Zooplankton response to a warmer northern Wadden Sea. *Helgol. Mar. Res.* 62, 67–75. doi:10.1007/s10152-007-0097-0
- Miller, P.J., 1975. Age structure and life span in the common goby, *Pomatoschistus microps*. *J. Zool.* 177, 425–448.
- Miller, P.J., 1986. Gobiidae, in: Wittehead, P., Bauchat, M., Hureau, J., Nielsen, J., Tortonese, E. (Eds.), *Fishes of the North-Eastern Atlantic and the Mediterranean*. UNESCO, Paris, pp. 1019–1085.
- Miller, P.J., 2004. *Pomatoschistus microps*, in: Miller, P.J. (Ed.), *The Freshwater fishes of Europe*. AULA Verlag, Wiesbaden, pp. 293–300.
- Monaco, M.E., Ulanowicz, R.E., 1997. Comparative ecosystem trophic structure of three US . mid-Atlantic estuaries. *Mar. Ecol. Prog. Ser.* 161, 239–254.
- Moore, J., Moore I.A., 1976. The basis of food selection in flounders, *Platichthys flesus* (L.), in the Severn Estuary. *J. Fish Biol.* 9, 139–156.
- Norte-Campos del, A.G.C., 1995. Ecological studies on the coexistence of the brown shrimp *Crangon crangon* L and the gobies *Pomatoschistus microps* Krøyer and *P. minutus* Pallas in shallow areas of the German Wadden Sea. University of Hamburg.
- Norte-Campos del, A.G.C., Temming, A., 1994. Daily activity, feeding and rations in gobies and brown shrimp in the northern Wadden Sea. *Mar. Ecol. Prog. Ser.* 115, 41–53. doi:10.3354/meps115041
- Ntiba, M.J., Harding, D., 1993. The food and the feeding habits of the long rough dab, *Hippoglossoides platessoides* (Fabricius 1780) in the North Sea. *J. Sea Res.* 31, 189–199.
- Paine, R., 1969. A note on trophic complexity and community stability. *Am. Nat.* 103, 91–93.
- Pihl, L., 1985. Food selection and consumption of mobile epibenthic fauna in shallow marine areas. *Mar. Ecol. Prog. Ser.* 22, 169–179. doi:10.3354/meps022169
- Pihl, L., Rosenberg, R., 1982. Production, abundance and biomass of mobile epibenthic marine fauna in shallow waters, western Sweden. *J. Exp. Mar. Bio. Ecol.* 51, 273–301.

-
- Piraino, S., Fanelli, G., Boero, F., 2002. Variability of species' roles in marine communities: change of paradigms for conservation priorities. *Mar. Biol.* 140, 1067–1074. doi:10.1007/s00227-001-0769-2
- Polte, P., Schanz, A., Asmus, H., 2005. The contribution of seagrass beds (*Zostera noltii*) to the function of tidal flats as a juvenile habitat for dominant, mobile epibenthos in the Wadden Sea. *Mar. Biol.* 147, 813–822. doi:10.1007/s00227-005-1583-z
- Power, E., Tilman, D., Estes, J., Menge, B., Bond, W., Mills, L., Daily, G., Castilla, J., Lubchenco, J., Paine, R., 1996. Challenges in the quest for keystones. *Biol. Sci.* 46, 607–620.
- Reise, K., 1979. Moderate predation on meiofauna by the macrobenthos of the Wadden Sea. *Helgol. Mar. Res.* 32, 453–465.
- Ropes, J.W., 1968. The feeding habits of the green crab, *Carcinus maenas* (L.). *Fish. Bull.* 67, 183–203.
- Scheiffarth, G., Nehls, G., 1997. Consumption of benthic fauna by carnivorous birds in the Wadden Sea. *Helgol. Mar. Res.* 387, 373–387.
- Ulanowicz, R.E., Puccia, C., 1990. Mixed trophic impacts in ecosystems. *Coenoses* 5, 7–16.
- Vorberg, R., Breckling, P., 1999. Atlas der Fische im Schleswig-Holsteinischen Wattenmeer. Schriftenr. des Natl. Schleswig-Holsteinisches Wattenmeer 10, 178.
- Widbom, B., 1984. Determination of average individual dry weights and ash-free dry weights in different sieve fractions of marine meiofauna. *Mar. Biol.* 108, 101–108.
- Winberg, G.G., 1956. Rate of metabolism and food requirements of fishes. *J Fish Res Board Can Transl Ser* 202.
- Wootton, T.J., 1994. Predicting direct and indirect effects: an integrated approach using experiments and path analysis. *Ecology* 75, 151–165.
- Wootton, T.J., Parker, M.S., Power, M.E., 1996. Effects of disturbance on river food webs. *Science* (80-). 273, 1558–1561.
- Wulff, F., Field, J.G., Mann, K.H., 1989. Coastal and Estuarine Studies, in: Wulff, F., Field, J.G., Mann, K.H. (Eds.), *Coastal and Estuarine Studies* 32. Springer-Verlag, Heidelberg.
- Zander, D., Hartwig, E., 1982. On the biology of small-seized fish from North and Baltic Sea areas. IV. Investigations on an eulittoral mud flat at Sylt island. *Helgol. Mar. Res.* 35, 47–63.

**CHAPTER III. INVESTIGATION OF FISH SPECIES OCCURRENCE AND COMPOSITION
INTRODUCED ALGAL FORESTS (*SARGASSUM MUTICUM*): PROVIDING A NEW HABITAT FOR
NATIVE FISH?**



Pictures p. 121 Sampling gear and fish caught. Top: Trawl net arranged before the haul; Middle: measuring of *Spinachia spinachia* (sea stickleback); Bottom: trawled *Clupea harengus* (hering) and *Ammodytes tobianus* (sand lance).

Source and copyright: Christian Höfs, Moritz Pockberger

**CHAPTER III. INVESTIGATION OF FISH SPECIES OCCURRENCE AND COMPOSITION
INTRODUCED ALGAL FORESTS (*SARGASSUM MUTICUM*): PROVIDING A NEW HABITAT FOR
NATIVE FISH?**

Moritz Pockberger*, Florian Kellnreitner, Ragnhild Asmus, Harald Asmus

Alfred Wegener Institute, Helmholtz Centre for Polar and Marine Research, Wadden Sea Station Sylt, Hafenstrasse 43, D-25992 List, Germany

*corresponding author: moritz.pockberger@awi.de

Abstract

The introduced oyster *Crassostrea gigas* is one of the most abundant habitat forming invertebrates along European coasts. Oysters established vast reefs providing facilitating settlement of additional nonindigenous species, such as the Japanese wireweed *Sargassum muticum*. The algae grow in dense forests providing possible new habitats for native and introduced species. Little is known on the impact of these algal forests on native fish communities. Forests might act as substitute for lost seagrass beds and provide suitable habitats for threatened species. We hypothesise that dense algal canopies influence occurrence and abundance of fish. Sampling of fish species was conducted in July and August 2010 in a *S. muticum* forest and on sandy areas, employing various methods. In total 29 fish species were sampled. Three species (*Anguilla anguilla*, *Pomatoschistus microps* and *Spinachia spinachia*) were found exclusively in *S. muticum*. Results indicate high abundances of *P. flesus* in algal forest, mean catch per unit effort $0.5 \pm 0.4 \text{ ind net}^{-1} \text{ h}^{-1}$ respectively $81.0 \pm 75.9 \text{ g net}^{-1} \text{ h}^{-1}$. The fish species inside *S. muticum* differed significantly to the species composition sampled at sandy areas. Results indicate that areas covered by *S. muticum* are attractive for certain native species and may enable the reestablishment of lost and threatened species.

Key words

Sargassum muticum; *Crassostrea gigas*; Wadden Sea; introduced species; submerged aquatic vegetation; bioengineering, *Spinachia spinachia*

1. Introduction

Extensive tidal flats of the Wadden Sea are dominated by soft sediments and complex benthic structures are mostly biogenic formed by habitat generating species, such as epibenthic mussels, oysters and aquatic vegetation (Polte et al., 2005; Reise, 2005). These complex habitats are formed by bioengineers, and provide important nursery areas and foraging grounds for various species (Polte and Asmus, 2006). The historic loss of subtidal seagrass meadows formerly formed by *Zostera marina* was a loss of structural complexity in the Wadden Sea and might result in a decrease of species abundance and biodiversity (Polte and Buschbaum, 2008; Wolff, 2000). The Pacific oyster, *Crassostrea gigas*, and the Japanese wireweed, *Sargassum muticum*, are engineer species providing habitats by their high individual abundance and forming of biogenic structures (Britton-Simmons, 2004; Leguerrier et al., 2004; Reise, 2005). The Pacific oyster overgrew beds of the blue mussel *Mytilus edulis*, becoming one of the most abundant invertebrates in inter- and shallow subtidal areas of the Wadden Sea (Büttger et al., 2011). After the introduction of *C. gigas* in Europe the establishment of *S. muticum*, which settles on hard substrata, was predicted by Druehl (1973). Today *C. gigas* and *S. muticum* occur in many different inter- and subtidal areas along the European Wadden Sea coast (Buschbaum et al., 2012; Critchley et al., 1990a). The brown algae was first described along coasts of the Netherlands at lake Grevelingen (Critchley et al., 1990b) and found 1993 in northern parts of the Wadden Sea at the island of Sylt (Schories et

al., 1997). In northern areas *S. muticum* grows from early spring until fall and then thalli are detached and are drifting away (Polte and Buschbaum, 2008; Schories et al., 1997).

In the main vegetation period, July and August, individual thalli of Japanese wireweed reach a length up to 2 m and densities are estimated up to 7 thalli 10 m^{-2} (Polte and Buschbaum, 2008; Schories et al., 1997). Investigations focusing on *S. muticum* abundance in Wadden Sea areas examine competition with native algal species and the influence on abundance and occurrence of meio- and invertebrated macrofauna (Buschbaum et al., 2006; Lang and Buschbaum, 2010; Stæhr et al., 2000). *Sargassum muticum* colonising areas with low macroalgal cover provide new habitats for epifauna, which again attract fish preying on these small invertebrates. This results in an increased secondary production (Viejo, 1999). In Wadden Sea areas, Polte and Buschbaum (2008) assumed that *S. muticum* forests in the shallow subtidal areas might provide important habitats for fish species which formerly inhabited lost subtidal *Z. marina* meadows. In their transplantation experiment *S. muticum* thalli were transferred to bare sand flats and the colonisation by two native endangered species *Entelurus aequoratus*, the snake pipefish, and *Spinachia spinachia*, the sea stickleback, was observed.

Although the invasion ecology of *S. muticum* has been intensely studied, few data are available concerning a response of the native fish community on the forming of a new habitat. Based on results of studies presented above we hypothesised that *S. muticum* forests influence abundance and occurrence of fish.

The aim of the study was to answer the following questions:

Which fish species are found associated with *S. muticum* during the algae's main vegetation period? Does the species composition and abundance of fish species differ compared to subtidal sandy areas? Is *S. muticum* inhabited by endangered fish species, which depend on

subtidal plant canopies? Finally due to the reason that various sampling methods were employed during this investigation and the installation and field work proved to be very time consuming different aspects of deployed net types will be discussed.

2. Materials & Methods

2.1. Study site

This study was conducted in the Sylt-Rømø bight (SRB) (54° 52' - 55° 10'N, 8° 20' - 8° 40'E), which is situated between the islands of Sylt (Germany) and Rømø (Denmark) and is a part of the Wadden Sea, which extends along the coast of the south-eastern North Sea reaching from the Netherlands to Denmark. The bight comprises an area of 404 km², including 135 km² of tidal flats (Asmus and Asmus, 2000). Two causeways connecting the islands with the mainland inhibit the movement of water around the islands and direct exchange with adjacent tidal basins. Between the islands there is only one tidal inlet of 2 km width and 40 m depth (Bayerl and Köster, 1998) (Fig. 1a). The tidal range inside the bight is up to 2 m (Martens and Beusekom, 2008). A detailed description of the SRB is given in Gätje and Reise (1998). Investigations were conducted in July and August 2010 in a *S. muticum* forest, situated in the SRB, with a density of 10-15 thalli per m² (Fleckenstein, 2011; Buschbaum, pers. comm.) (Fig. 1b). During the sampling period mean monthly water temperatures ranged from 19°C to 21°C in the SRB and salinity varied from 31 to 30. Investigated areas were situated in the subtidal zone. Mean water depth ranged between 0.5 m at low tide to 2.5 m at high tide in *S. muticum* forest.

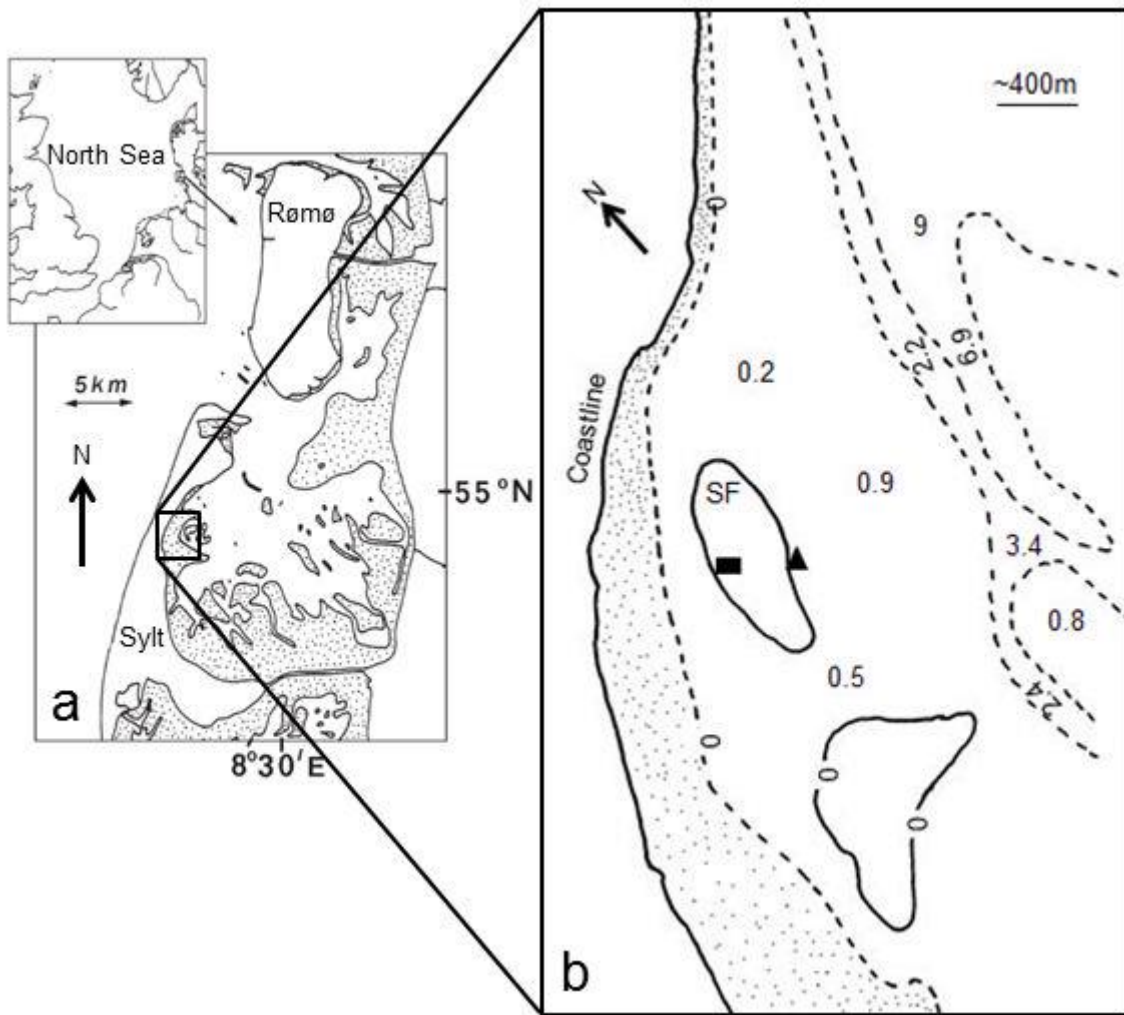

Fig. 1a. Position of the islands Sylt and Rømø in the North Sea and tidal areas of the Sylt - Rømø bight; stippled areas indicated intertidal flats, redrawn after (Asmus and Asmus, 2000).
 Fig. 1b. Drawing of sampling sites. Stippled areas indicate intertidal flats, broken lines give contour lines, numbers indicate depths in meter (Chart Datum mean lower low water after BSH N.F.S-Edition 29/2000). SF = *S. muticum* forest. Trammel net sampling station marked by black triangles, block net sampling station by black rectangle.

2.2. Sampling and laboratory analyses of fish

Two trammel nets (length 25 m, height 3 m mesh size 40 mm) (Fig. 2a) were set in a *S. muticum* forest on four consecutive days. The nets were set for six hours at the incoming tide and hauled at the beginning ebb tide.

To sample small, not easily visible fish species, which could not be assessed with trammel nets, 12 fyke nets (Fig. 2b) were randomly set in *S. muticum* forest at the beginning of high tide and controlled at the end of low tide. As bait leftovers of *Carcinus maenas* and *Mytilus edulis*, sampled for other investigations, as well as glow sticks, were used. Nets were installed 100 mm above the sediment attached to iron rods.

To investigate the abundance of fish, independent of their size, in *S. muticum* forests a device to shoo fish, the “Fish Sweeper”, (Fig. 2c) and a block net sampling approach (Fig. 2d) were developed and set up in August. First four parallel walls of plastic grid and netting, as block nets, (mesh size 5 mm, length 10 m, height 2 m) were installed, each wall in 5 m distance to the following. Then the area was left to settle for 24 hours. At sampling, at the beginning of low tide, the four block net walls were connected by plastic grid, thus enclosing three sections each with an area of 50 m². Before sampling was conducted in the first section, on one side the plastic grid was carefully removed and simultaneously replaced by a purse seine in a way which prevented fish from escaping the section. After the purse seine was installed *S. muticum* thalli were carefully removed after inspecting them for possibly entangled fish. Then the section was swept using the “Fish Sweeper”. Fish trapped in the purse seine were removed, killed and preserved in 5% buffered formalin solution for further analyses. Then the following two sections were swept.

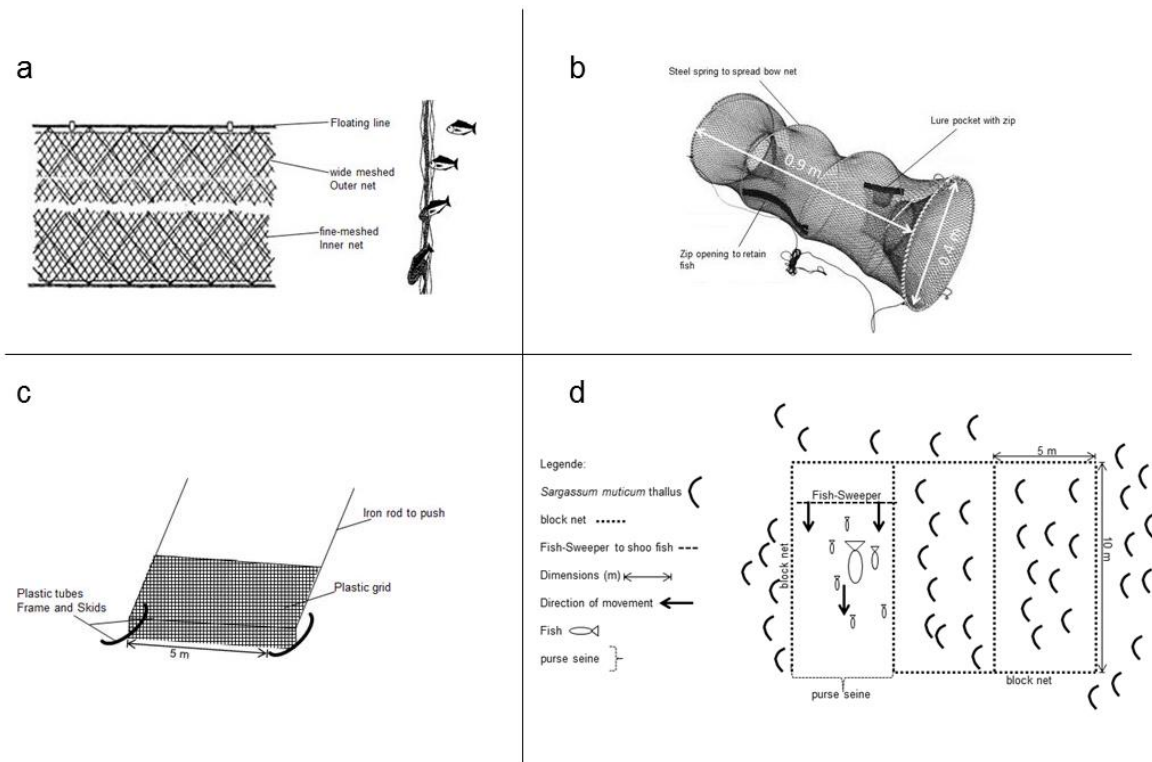

Fig. 2a. Components and function of a trammel net. Fish bounces the inner net, by turning it is trapped in a pocket, redrawn after (Lloyd and Mounsey, 1998) and (Nédélec and Prado, 1999). Fig. 2b. Components and adjustment of a fyke net. Fish swim into the opening and are trapped, redrawn after ENGEL-NETZE GmbH and Co. KG. Fig. 2c. "Fish-Sweeper" used in *S. muticum* forest. The device is pushed, gliding over the sediment, plastic grid sweeps the sediment and through the water column and shoos fish (mesh size 5 mm). Fig. 2d. Sampling strategy in *S. muticum* forest. Before sampling four block net walls of plastic grid (height 2 m, length 10 m, mesh size 5 mm) were erected in a distance of 5 m to the adjacent wall. On sampling date areas were enclosed using the same material. Areas were sampled one after the other in the following procedure: I. On one side of the enclosed area the block net was removed and a purse seine was installed. On the opposite the "Fish-Sweeper" was positioned. II. *S. muticum* thalli were removed from enclosed area. III. Fish-Sweeper was pushed in the direction of the purse seine, as soon as the total length of area was swept, the seine net was closed and trapped individuals collected.

In the laboratory total length (TL) of individuals, sampled by trammel and fyke nets, was measured to the nearest mm, and the wet weight (WW), to 0.1 g, was weighted. Individuals sampled in the block net approach were measured to the nearest mm, TL and WW was weighted to 0.01 g for further analyses.

To get an overview which fish species were present during the time of investigation, data of the long-term monthly fish survey of the Wadden Sea Station Sylt, which was conducted contemporary to the above described samplings, were pooled and included in this

investigation. The survey was conducted covering different sandy areas situated in subtidal zone inside and outside the bight. For sampling a mini bottom trawl (length 17 m, width 7 m, height 3 m, mesh size wings: 32 mm, mid part: 16 mm, cod end: 6 mm) which can also be used as fyde trawl, for pelagic fishing, was employed (Fig. 2e).

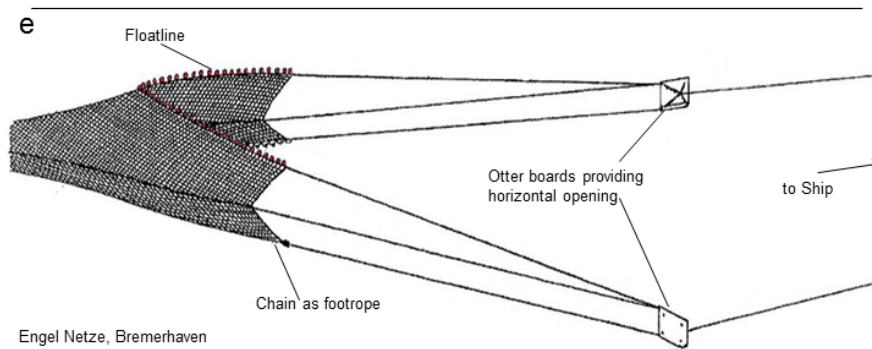

Fig. 2e. Arrangement of a trawl net, which is towed through the water after ENGEL-NETZE GmbH.

Fish were identified to species level and TL was measured to the closest 5 mm. The WW (g) was calculated employing current length-weight relationships of fish sampled during the long-term survey (Eq. 1). For species with only few sampled individuals (*Belone belone*, *Callionymus lyra*) constants to calculate WW, sampled at the nearest geographic location, were taken from www.fishbase.org (accessed 11 Aug 2014).

$$WW = a * l^b \quad (1)$$

Where l = length in cm, a and b depict constants for every species.

2.3. Data analyses

Data was sampled in the main vegetation period of *S. muticum*, which lasts from the beginning of July until end of August in the SRB. To overview data of fish sampled by trammel-, fyke, block nets and during the long-term survey mean individual TL, mean

individual WW, standard deviations (SD), the size range and the total WW of sampled species were calculated.

To compare fish densities sampled using different sampling approaches in *S. muticum* and other subtidal areas in the SRB catch per unit effort (CPUE) per hour using the WW and the numbers of individuals were calculated for every species (Galal et al., 2002) (Eq.2). The mean CPUE for every method over all sampling days was calculated. To present results comparable to other investigations additionally the abundance, WW and SD of species were calculated for the block net approach and data of the long-term fish survey. Abundance and WW data of each species were extrapolated and standardised to individuals 1000 m⁻².

$$\text{CPUE} = W * (T * N)^{-1} \quad (2)$$

Where W = wet weight of all sampled individuals in g or the number of sampled individuals, T = number of hours fishing gear was in the water excluding set and haul time, N = number of nets.

2.4. Statistical treatment

To calculate for statistical differences between sandy areas and *S. muticum* forests the CPUE's (ind net⁻¹ h⁻¹) were used. The routines of PRIMER v6 were employed to calculate a one way analyses of similarities (ANOSIM) and the similarity percentage (SIMPER) (Clarke and Gorley, 2006). ANOSIM, number of permutations 999, was calculated giving the measures R and p. Values of R range from +1 to -1 and indicate the separation of the samples between the groups, +1 shows good separation, 0 no separation (Clarke, 1993). The significance level is indicated by the p-value, significance was assumed if the p-value was less than 0.05. When statistical differences between the sandy areas and *S. muticum* forest were

found, a SIMPER routine was employed to calculate the average dissimilarity and apportion the percentage contributions of fish species to the dissimilarity. Values of average dissimilarity range from 0 to 100 percent, 100 indicating complete dissimilarity.

3. Results

Overall 29 fish species were sampled using different sampling methods during this investigation (Table 1). In samplings conducted with trawl net on sandy areas 26 species were found (Table 1). In *S. muticum* forests nine species were caught. Three species, *Anguilla anguilla*, *Pomatoschistus microps* and *Spinachia spinachia* were sampled only in *S. muticum* forests. Analysing trawl data, sampled at sandy areas, highest CPUE's and abundances were observed for *Clupea harengus* (15956.8 ± 45370.7), *Trachurus trachurus* (127.4 ± 454.4) and *Ammodytes tobianus* (114.6 ± 491.0) (Table 1). Numbers of CPUE's ($\text{ind net}^{-1} \text{ h}^{-1}$) are given in parentheses.

In *S. muticum* forests using trammel nets 23 individuals of *Platichthys flesus* (0.5 ± 0.4) were caught (Table 1). Employing fyke nets three fish species *P. microps* ($<0.1 \pm 0.2$), *S. spinachia* ($<0.1 \pm 0.04$) and *Zoarces viviparus* ($<0.1 \pm 0.2$) were sampled (Table 1). In the block net approach nine fish species were counted (Table 1). Highest CPUE's were calculated for *P. microps* (265.3 ± 96.1), followed by *Z. viviparus* (42.7 ± 4.6) and *Syngnathus rostellatus* (12.0 ± 0.0) (Table 1).

While at sandy areas pelagic orientated species, such as *C. harengus*, *T. trachurus* and *A. tobianus* were found in high abundances and numbers, comparison of presented CPUE's showed that benthic oriented species dominated in *S. muticum* forests (Table 1). Only one pelagic foraging species, *C. harengus* (2.7 ± 4.6), was found to be present in the algal forest

(Table 1). The subtidal plant canopy seemed to be attractive for *P. flesus* as in total more than 4000 g were sampled compared to about 3 g in sandy areas (Table 1).

Also statistical calculations showed differences between sandy areas and *S. muticum* forest. Results of ANOSIM revealed a degree of separation between the different groups ($R = 0.271$) which is statistical significant ($p\text{-value} = 0.001$) (Table 2). In order to explore which species contribute to the separation between the two groups the SIMPER routine was applied. This routine showed dissimilarity between areas covered by *S. muticum* and open sandy areas of 99.71% (Table 2). Following the results of analyses seven species contributed to the observed dissimilarity, whereas highest percentages were calculated for *C. harengus* (31.72%) and *Syngnathus rostellatus* (30.27%) (Table 2).

<i>Belone belone</i>	1	<0.1±0.1	0.2±0.8	4.2±21.3	310	310.0	0.2±0.8	27.2	27.2
<i>Callionymus lyra</i>	2	<0.1±0.1	0.3±1.6	0.9±4.4	155-160	157.5±1.8	<0.1±0.2	2.8±0.0	5.6
<i>Ciliata mustela</i>	1	<0.1±0.1	0.2±0.8	1.5±7.4	110	110.0	<0.1±0.3	9.4	9.4
<i>Clupea harengus</i>	103719	615.4±1749.9	15956.8±45370.7	24566.3±70450.4	40-95	63.2±8.2	947.5±2717.2	1.9±0.6	159680.8
<i>Engraulis encrasicolus</i>	1	<0.1±0.1	0.2±0.8	<0.1±0.3	45	45.0	<0.1±0.1	0.3	0.3
<i>Gadus morhua</i>	6	<0.1±0.1	0.9±2.6	5.4±16.5	70-100	87.5±8.9	0.2±0.6	5.5±0.9	35.3
<i>Gasterosteus aculeatus</i>	4	<0.1±0.1	0.6±1.9	0.3±0.9	35-45	40.0±5.9	<0.1±0.1	0.5±0.1	2.0
<i>Hyperoplus lanceolatus</i>	8	0.1±0.1	1.2±3.5	24.9±84.8	110-250	192.5±6.2	1.0±3.3	20.0±13.7	161.6
<i>Lampetra fluviatilis</i>	7	<0.1±0.2	1.1±4.7	12.0±54.0	175-200	191.4±12.5	0.5±2.1	10.3±1.1	77.8
<i>Merlangius merlangus</i>	72	0.4±1.3	11.1±35.4	69.7±178.7	60-130	89.7±3.3	2.7±6.9	8.5±3.3	452.8
<i>Mullus surmuletus</i>	1	<0.1±0.1	0.2±0.8	0.3±1.3	60	60.0	<0.1±0.1	1.7	1.7
<i>Myoxocephalus scorpius</i>	36	0.2±0.8	5.5±19.6	50.9±169.7	35-160	64.3±5.5	2.0±6.5	12.6±15.2	330.8
<i>Osmerus eperlanus</i>	2	<0.1±0.1	0.3±1.1	9.7±34.4	165-170	167.5±1.8	0.4±1.3	31.6±1.6	63.3
<i>Pholis gunnellus</i>	25	0.2±0.4	3.9±9.6	26.5±62.7	105-160	125.6±7.6	1.0±2.4	7.8±2.9	172.3
<i>Platichthys flesus</i>	1	<0.1±0.1	0.2±0.8	0.4±2.1	70	70.0	<0.1±0.1	2.7	2.7
<i>Pleuronectes platessa</i>	129	0.8±2.7	19.9±69.3	40.2±118.9	50-90	60.7±6.5	1.6±4.6	3.3±1.6	261.2
<i>Pomatoschistus lozanoi</i>	1	<0.1±0.1	0.2±0.8	0.2±1.2	60	60.0	<0.1±0.1	1.5	1.5
<i>Pomatoschistus microps</i>	-	-	-	-	-	-	-	-	-
<i>Pomatoschistus minutus</i>	444	2.6±12.4	68.3±321.5	154.0±715.8	30-90	65.5±9.2	5.9±27.6	2.5±1.0	1000.7
<i>Solea solea</i>	3	<0.1±0.1	1.1±3.3	25.4±111.3	90-210	143.3±20.4	1.0±4.3	55.1±61.4	165.3
<i>Spinachia spinachia</i>	-	-	-	-	-	-	-	-	-
<i>Sprattus sprattus</i>	14	<0.1±0.3	2.2±7.9	10.06±37.2	75-115	87.1±11.6	0.4±1.4	5.5±3.0	65.4
<i>Syngnathus rostellatus</i>	102	0.6±0.6	15.7±16.3	11.3±12.1	50-160	118.0±5.4	0.4±0.5	0.7±0.4	73.6
<i>Trachurus trachurus</i>	828	4.9±17.5	127.4±454.4	95.0±364.3	15-60	41.8±6.1	3.7±14.1	0.7±0.3	616.9
<i>Triglidae sp.</i>	2	<0.1±0.1	0.3±1.1	2.0±7.3	80-90	85.0±8.3	0.1±0.3	6.5±1.6	13.1
<i>Zoarces viviparus</i>	60	0.4±1.0	9.2±26.8	84.8±213.2	80-250	114.9±8.1	3.3±8.2	14.6±12.2	551.2

Table 2. Results of analyses of similarities (ANOSIM), R and p – values, and of similarity percentage (SIMPER) calculations comparing habitats. Values of SIMPER are given in percent and show dissimilarity between *S. muticum* forests and sandy areas considering the occurrence of fish, below species are listed according to their contribution to observed dissimilarity.

EMPLOYED TEST	RESULTS
ANOSIM	R = 0.271, P = 0.001
SIMPER	
Overall Average Dissimilarity	99.71
Species contribution to Dissimilarity	
<i>Clupea harengus</i>	31.72
<i>Syngnathes rostellatus</i>	30.27
<i>Ammodytes tobianus</i>	8.12
<i>Trachurus trachurus</i>	7.06
<i>Pomatoschistus microps</i>	4.84
<i>Pomatoschistus minutus</i>	4.51
<i>Platichthys flesus</i>	4.41

4. Discussion

Three species were exclusively found in *S. muticum* forest during this investigation. Following Jacoby and Gollock (2014) *A. anguilla* is a critically endangered species, *P. microps* is not endangered as the species status is “least concern” and *S. spinachia* was not evaluated, but listed as vulnerable by Berg et al. (1996). In the course of the year 2010 in total 6 individuals of *S. spinachia* were sampled during the long-term fish survey covering several stations in the SRB (Pockberger & Kellnreitner, unpublished data). All individuals were sampled before (March) or after (September/October) the main vegetation period of *S. muticum*. This might indicate that individuals are more sedentary in algal forests while thalli form dense subtidal canopies and disperse when *Sargassum* thalli are small or detached in fall. Kruuk et al. (1988) and Potts et al. (1988) report that *S. spinachia* inhabits areas covered

by subtidal plants, preferring sheltered habitats. In the course of the year 2011, 51 individuals were sampled during the monthly fish survey in the SRB (Pockberger & Kellnreitner, unpublished data). In contrast to Polte and Buschbaum (2008) no individuals of *E. aequorus* were found, but the occurrence and increasing number of *S. spinachia* two years after their investigation seems to proof the assumption that *S. muticum* forests provide an alternative to lost subtidal *Z. marina* habitats and that a stable population of *S. spinachia* might establish. *Spinachia spinachia* is also described as a highly resilient fish species due to a population doubling time less than 15 months (Froese and Pauly, 2010).

No individuals of *A. anguilla* were sampled in the long term fish survey in 2010, although this species was present in other surveys and monitorings in the Wadden Sea and North Sea (Jager et al., 2009). In the SRB (Zander and Hartwig, 1982) found high numbers of migrating individuals of *A. anguilla*. Few individuals remain over a longer period in Wadden Sea areas, as they were found to be abundant beyond migration season in structured areas, e.g. mussel beds (Herrmann et al., 1998; Vorberg and Breckling, 1999). Dense *S. muticum* forests might provide a suitable sheltered habitat along the migration routes of this catadromous species and a temporary foraging ground for resident individuals.

The absence of *P. microps* in samples of the long term fish survey might be explained by the range of the employed trawl net. *Pomatoschistus microps* prefer the very shallow parts of the intertidal sand flats as well as sheltered areas such as intertidal seagrass beds in the SRB, but these areas are outside the operation distance of the research vessel with its bottom trawl. Previous investigations, particularly those using beach seines (Herrmann et al., 1998; Kellnreitner et al., 2012; Vorberg and Breckling, 1999; Zander and Hartwig, 1982), describe *P. microps* in high numbers and as one of the most abundant species in the Wadden Sea and

the SRB. This is in accordance with here presented abundances sampled in *S. muticum* forests, where *P. microps* was found to be the most abundant species.

4.1. Species abundance and composition

For the Wadden Sea up to 137 marine fish species are recorded (Jager et al., 2009). Herrmann et al. (1998) describe 50 species over a four year period occurring in the SRB, while up to 47 species were counted during the long-term survey over a period of 5 years (Chapter I, this investigation). Over the course of one year, 27 species were counted (Kellnreitner et al., 2012). During this investigation, in 2010, 29 fish species were sampled, which seems to present regularly occurring species in the SRB. Although (Viejo, 1999) described increased epifauna in *S. muticum* forests, compared to other areas, providing higher prey abundances for fish, only 9 species were caught.

The higher number of fish species in trawl catches might be due to larger sampling area compared to areas sampled in the *S. muticum* forest. Although trawls covered large areas, certain fish species were found exclusively in *Sargassum*.

Strong et al. (2006) described impacts on abiotic parameters, such as light, temperature and water movement, due to the high density of thalli in *S. muticum* forests. Changed abiotic parameters inside the dense algal canopies may be unfavorable for the majority of fish species and might cause avoidance.

Platichthys flesus was caught regularly, which might hint that *S. muticum* and closely adjacent areas depict attractive habitats for this species. In total 24 individuals of *P. flesus* were sampled in *S. muticum* forest during this investigation (23 individuals using trammel nets, 1 individual in the block net approach) (Table 1). Data of the monthly fish survey in the

SRB report a total of 8 individuals for the entire year 2010 (Pockberger & Kellnreitner, unpublished data). Bolle et al. (2009) provide long term averages of various fish surveys, using different methods, in Wadden Sea areas ranging from 0.3 to 3 ind 1000 m⁻² and 2 to 1400 ind 10⁻⁶ m⁻³. Veer et al. (2011) describe a loss in the nursery function of inter- and shallow subtidal areas for flatfish at Balgzand (Netherlands) and a significant decline of *P. flesus* in Dutch Wadden Sea areas, which are probably based on changes in offshore areas. Results indicate an articulate preference of *P. flesus* in the sampling period for *S. muticum*, as only 2 individuals were sampled using trammel nets in July 2010 on *C. gigas* reefs and none on bare sand flat (Pockberger & Kellnreitner, unpublished data). The high numbers of *P. flesus* sampled during this investigation in *S. muticum* forests, might be caused by abundant prey items. However, high prey abundance would also attract other fish species, found in the SRB. Fonds et al. (1992) investigated the metabolism of *P. flesus* and conclude that high respiratory capacity enables this species to forage in shallow coastal waters with high summer temperatures, unfavourable for other Wadden Sea fish species.

Although the investigation period is too short to identify long term trends results indicate possible positive effects for certain native and endangered fish species.

4.2. Discussion of sampling methods

A trawl net proved useful to sample species of various sizes in the water column and at unvegetated areas. Fast swimming species (e.g. *Belone belone*) might be underestimated due to the restriction of towing speed of 2 knots, albeit they were caught. Due to density of investigated *S. muticum* forests and the length and weight of thalli, the usage of a trawl net seemed not advisable. A trawl net is towed over a certain area collecting everything which does not slip through the net. The heavy weight of accumulated *Sargassum* thalli makes it

difficult to tow a sampling device through a dense canopy of large algae. This sampling method may also lead to complete destruction of the habitat. Connolly (1994) mentions fish escaped under a beach seine, used in dense meadows of seagrass, because the footrope of the net is held up by the plants and does not sweep the sediment. Benthic fish species might also escape by swimming under the footrope if the net is towed over coarse and uneven structures (Parsley et al., 1989), such as oyster reefs. The application of heavy chains on a trawl net might have solved the lift of the footrope (Fig. 2), but as mentioned above this might have caused a major impact on the algal forest.

Trammel nets proved useful to estimate the number of large fish for this investigation. Although trammel nets are highly effective, the method is not suitable for small sized fish species (Thomas et al., 2003). Due to the entanglement of thalli which lead to disarrangement and destruction of sampling gear, nets could not be set directly inside the *S. muticum* forest. Gear was set as close as possible to the outer boundary of the plant canopy. The method turned out to be very time consuming, since drifting algae and large numbers of entangled *Carcinus maenas* (green shore crab) had to be removed carefully, before nets could be repaired and adjusted for the next sampling. Species preying by visual clues might have seen the trammel net and avoided it, but *P. flesus* is described as a visual day feeder (Holmes and Gibson, 1983) and was caught in high numbers in the *S. muticum* forest compared to sand flats.

Fyke nets are suitable gear to collect fish in densely vegetated areas (Hubert et al., 2012), but they are size selective, may overestimate mobile fish species and catchability depends on bait materials used during sampling (Rozas and Minello, 1997). Nets were installed above the sediment to prevent *C. maenas* from entering, which seemed futile as up to 16

individuals were found trapped. This may be a reason for the low number of fish collected, though no fish carcass was found. Albeit individual numbers of fish in fyke nets were low, this method adds information to the species composition of small seized fish present in a *S. muticum* forest.

Block net approaches and the removal of plant material out of the enclosed area before sampling fish are reliable, but time consuming and personnel intensive methods to investigate fish abundance in dense plant canopies (Lambou, 1959; Barnett and Schneider, 1974; Rozas and Minello, 1997). Morton (1990) states that installation of block net sampling might influence fish abundance in sampled areas. By installing side walls 24 hours before sampling and restrict activities as much as possible, disturbances were kept to a minimum. Although sampling procedures started as soon as water was shallow enough, approximately 1 hour before low tide, to provide as much time as possible in the field, each enclosed section could be sampled only once. Therefore catch efficiency cannot be calculated. Rozas and Minello (1997) comparing different enclosure samplers gave high catch efficiencies above 70% for these methods. Although each employed type of sampling device might have limitations, the combination of different techniques and methods enables the sampling of fish species regardless of their size throughout the water column. The here presented results allow a first assessment of the occurrence and abundance of fish species in a newly formed habitat.

5. Conclusions

This investigation gives a first insight which fish species are found in and around new habitats formed by *S. muticum*. Results indicate an influence on fish abundance and occurrence, as certain species were caught exclusively in the vegetated area, indicating that

subtidal plant canopies may enable a reestablishment of native endangered species. The stability and interannual variability of endangered species populations will be revealed in long-term surveys.

Out of 29 species present in the whole investigated area, 9 species were found abundant in algal forest. Following investigations may show if the comparable low species number can be based on unfavorable abiotic conditions. Comparing individual abundances sampled during this survey to other monitoring programs in the Wadden Sea, *S. muticum* forests seem to depict attractive for certain fish species, such as *P. flesus*.

Acknowledgments

We thank Reimer Magens and Christian Buschbaum, their experience facilitated the construction of sampling gear used in *S. muticum* forests. We are grateful to Birgit Hussel, Petra Kadel, Anna Broich, Niels Reinecke, Tim Katzenberger and the participants of the Sylt course 2010, organised by Prof. Dr. Harald Ahnelt (University of Vienna), they were a great help sampling fish and never lost their good humor. We want to thank the crew of the RV MYA, Alfred Resch and Kai von Bohlen. At last we thank Patrick Polte who improved the manuscript through highly constructive criticisms.

References Chapter III

- Asmus, H., Asmus, R., 2000. Material exchange and food web of seagrass beds in the Sylt-Rømø bight: how significant are community changes at the ecosystem level? *Helgol. Mar. Res.* 54, 137–150.
- Barnett, B.S., Schneider, R.W., 1974. Fish populations in dense submerse plant communities. *Hyacinth Control J.* 12–14.
- Bayerl, R., Köster, K., 1998. Morphodynamik des Lister Tidebeckens, in: Gätje, C., Reise, K. (Eds.), *Ökosystem Wattenmeer - Austausch-, Transport- Und Stoffumwandlungsprozesse*. Springer, Berlin, Heidelberg, New York, pp. 25–29.
- Berg, S., Krog, C., Muus, B., Nielsen, J., Fricke, R., Berghahn, R., Neudecker, T., Wolff, W., 1996. IX. Red List of Lampreys and marine fishes of the Wadden Sea. *Helgol. Mar. Res.* 50, 101–105.
- Bolle, L.J., Neudecker, T., Vorberg, R., Damm, U., Diederichs, B., Jager, Z., Scholle, J., Daenhardt, A., Lüerßen, G., Marencic, H., 2009. Trends in Wadden Sea fish fauna Part I : Trilateral Cooperation.
- Britton-Simmons, K., 2004. Direct and indirect effects of the introduced alga *Sargassum muticum* on benthic, subtidal communities of Washington State, USA. *Mar. Ecol. Prog. Ser.* 277, 61–78.
- Buschbaum, C., Chapman, A.S., Saier, B., 2006. How an introduced seaweed can affect epibiota diversity in different coastal systems. *Mar. Biol.* 148, 143–161. doi:10.1007/s00227-005-0128-9
- Buschbaum, C., Lackschewitz, D., Reise, K., 2012. Nonnative macrobenthos in the Wadden Sea ecosystem. *Ocean Coast. Manag.* 68, 89–101. doi:10.1016/j.ocecoaman.2011.12.011
- Büttger, H., Nehls, G., Witte, S., 2011. High mortality of Pacific oysters in a cold winter in the North-Frisian Wadden Sea. *Helgol. Mar. Res.* 65, 525–532. doi:10.1007/s10152-011-0272-1
- Clarke, K., 1993. Non-parametric multivariate analyses of changes in community structure. *Aust. J. Ecol.* 18, 117–143.
- Clarke, K., Gorley, R., 2006. *PRIMER v6: User Manual/Tutorial*. PRIMER-E, Plymouth.
- Connolly, R.M., 1994. Removal of seagrass canopy: effects on small fish and their prey. *J. Exp. Mar. Bio. Ecol.* 184, 99–110. doi:10.1016/0022-0981(94)90168-6
- Critchley, A.T., Farnham, W.F., Yoshida, T., Norton, T.A., 1990a. A bibliography of the invasive alga *Sargassum muticum* (Yendo) Fensholt (Fucales; Sargassaceae). *Bot. Mar.* 33, 551–562. doi:10.1515/botm.1990.33.6.551

-
- Critchley, A.T., Visscher, P.R.M., Nienhuis, P.H., 1990b. Canopy characteristics of the brown alga *Sargassum muticum* (Fucales, Phaeophyta) in lake Grevelingen, southwest Netherlands. *Hydrobiologia* 204-205, 211–217. doi:10.1007/BF00040236
- Druehl, L.D., 1973. Marine Transplantations. *Science* (80-). 179, 12.
- Fleckenstein, N., 2011. The role of the immigrant *Caprella mutica* in coastal ecosystems of the German Bight. Carl von Ossietzky Universität, Oldenburg.
- Fonds, M., Cronie, R., Vethaak, A.D., Puyl, R., 1992. Metabolism, food consumption and growth of plaice (*Pleuronectes platessa*) and flounder (*Platichthys flesus*) in relation to fish size and temperature. *Netherlands J. Sea Res.* 29, 127–143.
- Froese, R., Pauly, D., 2010. FishBase. <http://www.fishbase.org> (accessed 18 Aug 2014).
- Galal, N., Ormond, R., Hassan, O., 2002. Effect of a network of no-take reserves in increasing catch per unit effort and stocks of exploited reef fish at Nabq, South Sinai, Egypt. *Mar. Freshw. Res.* 53, 199–205.
- Gätje, C., Reise, K., 1998. Ökosystem Wattenmeer - Austausch-, Transport- und Stoffumwandlungsprozesse. Springer, Berlin, Heidelberg, New York.
- Herrmann, J.P., Jansen, S., Temming, A., 1998. Fish and decapod crustaceans in the Sylt-Rømø bight, in: Gätje, C., Reise, K. (Eds.), Ökosystem Wattenmeer - Austausch-, Transport- Und Stoffumwandlungsprozesse. Springer, Berlin, Heidelberg, New York, pp. 81–88.
- Holmes, B.R.A., Gibson, R.N., 1983. A comparison of predatory behaviour in flatfish. *Anim. Behav.* 1244–1255.
- Hubert, W.A., Pope, K.L., Dettmers, J.M., 2012. Passive Capture Techniques. Nebraska Coop. Fish Wildl. Res. Unit Paper 111, 1–256.
- Jacoby, D., Gollock, M., 2014. *Anguilla anguilla* [WWW Document]. IUCN Red List Threat. Species. Version 2014.2.
- Jager, Z., Bolle, L., Dänhardt, A., Diederichs, B., Neudecker, T., Scholle, J., Vorberg, R., 2009. Thematic Report No. 14, in: Marencic, H., Vlas de, J. (Eds.), Wadden Sea Quality Status Report (QSR) 2009. Trilateral Monitoring and Assessment Group (TMAG) Common Wadden Sea Secretariat, Wilhelmshaven, pp. 1–42.
- Kellnreitner, F., Pockberger, M., Asmus, H., 2012. Seasonal variation of assemblage and feeding guild structure of fish species in a boreal tidal basin. *Estuar. Coast. Shelf Sci.* 108, 97–108. doi:10.1016/j.ecss.2011.02.020
- Kruuk, H., Nolet, B., French, D., 1988. Fluctuations in numbers and activity of inshore demersal fishes in Shetland. *J. Mar. Biol. Assoc. United Kingdom* 68, 601–617.

-
- Lambou, V.W., 1959. Block-off net for taking fish-population samples. *Progress. Fish-Culturist* 21, 143–144.
- Lang, A.C., Buschbaum, C., 2010. Facilitative effects of introduced Pacific oysters on native macroalgae are limited by a secondary invader, the seaweed *Sargassum muticum*. *J. Sea Res.* 63, 119–128. doi:10.1016/j.seares.2009.11.002
- Leguerrier, D., Niquil, N., Petiau, A., Bodoy, A., 2004. Modeling the impact of oyster culture on a mudflat food web in Marennes-Oléron Bay (France). *Mar. Ecol. Prog. Ser.* 273, 147–162. doi:10.3354/meps273147
- Lloyd, J.A., Mounsey, R.P., 1998. The potential of the trammel net as an alternative method for sampling fish on deep water reefs. *Fish. Res.* 39, 67–74.
- Martens, P., Beusekom, van J.E.E., 2008. Zooplankton response to a warmer northern Wadden Sea. *Helgol. Mar. Res.* 62, 67–75. doi:10.1007/s10152-007-0097-0
- Morton, R.M., 1990. Marine Biology in a subtropical Australian mangrove area. *Mar. Biol.* 105, 385–394.
- Nédélec, C., Prado, J., 1999. Definition and classification of fishing gear categories. *FAO Fish. Tech. Pap.* 222, 1–87.
- Parsley, M.J., Palmer, D.E., Burkhardt, R.W., 1989. Variation in capture efficiency of a beach seine for small fishes. *North Am. J. Fish. Manag.* 9, 239–244.
- Polte, P., Asmus, H., 2006. Influence of seagrass beds (*Zostera noltii*) on the species composition of juvenile fishes temporarily visiting the intertidal zone of the Wadden Sea. *J. Sea Res.* 55, 244–252. doi:10.1016/j.seares.2005.11.004
- Polte, P., Buschbaum, C., 2008. Native pipefish *Entelurus aequoreus* are promoted by the introduced seaweed *Sargassum muticum* in the northern Wadden Sea, North Sea. *Aquat. Biol.* 3, 11–18. doi:10.3354/ab00071
- Polte, P., Schanz, A., Asmus, H., 2005. The contribution of seagrass beds (*Zostera noltii*) to the function of tidal flats as a juvenile habitat for dominant, mobile epibenthos in the Wadden Sea. *Mar. Biol.* 147, 813–822. doi:10.1007/s00227-005-1583-z
- Potts, G.W., Keenleyside, M.H.A., Edwards, J.M., 1988. The effect of silt on the parental behaviour of the sea stickleback, *Spinachia spinachia*. *J. Mar. Biol. Assoc. United Kingdom* 68, 277–285.
- Reise, K., 2005. Coast of change: habitat loss and transformations in the Wadden Sea. *Helgol. Mar. Res.* 59, 9–21. doi:10.1007/s10152-004-0202-6
- Rozas, L.P., Minello, T.J., 1997. Estimating densities of small fishes and decapod crustaceans in shallow estuarine habitats : a review of sampling design with focus on gear selection. *Estuaries* 20, 199–213.

-
- Schories, D., Albrecht, A., Lotze, H., 1997. Historical changes and inventory of macroalgae from Königshafen bay in the northern Wadden Sea. *Helgol. Mar. Res.* 341, 321–341.
- Stæhr, P.A., Pedersen, M.F., Thomsen, M.S., Wernberg, T., Krause-Jensen, D., 2000. Invasion of *Sargassum muticum* in Limfjorden (Denmark) and its possible impact on the indigenous macroalgal community. *Mar. Ecol. Prog. Ser.* 207, 79–88.
- Strong, J., Dring, M., Maggs, C., 2006. Colonisation and modification of soft substratum habitats by the invasive macroalga *Sargassum muticum*. *Mar. Ecol. Prog. Ser.* 321, 87–97. doi:10.3354/meps321087
- Thomas, S.N., Edwin, L., George, V.C., 2003. Catching efficiency of gill nets and trammel nets for penaeid prawns. *Fish. Res.* 60, 141–150. doi:10.1016/S0165-7836(02)00057-7
- Veer, van der H., Koot, J., Aarts, G., Dekker, R., Diderich, W., Freitas, V., Witte, J., 2011. Long-term trends in juvenile flatfish indicate a dramatic reduction in nursery function of the Balgzand intertidal, Dutch Wadden Sea. *Mar. Ecol. Prog. Ser.* 434, 143–154. doi:10.3354/meps09209
- Viejo, R.M., 1999. Mobile epifauna inhabiting the invasive *Sargassum muticum* and two local seaweeds in northern Spain. *Aquat. Bot.* 64, 131–149. doi:10.1016/S0304-3770(99)00011-X
- Vorberg, R., Breckling, P., 1999. Atlas der Fische im Schleswig-Holsteinischen Wattenmeer. Schriftenr. des Natl. Schleswig-Holsteinisches Wattenmeer 10, 178.
- Wolff, W.J., 2000. The south-eastern North Sea: losses of vertebrate fauna during the past 2000 years. *Biol. Conserv.* 95.
- Zander, D., Hartwig, E., 1982. On the biology of small-seized fish from North and Baltic Sea areas. IV. Investigations on an eulittoral mud flat at Sylt island. *Helgol. Mar. Res.* 35, 47–63.

CHAPTER IV. INTERNAL PROCESSES OF A HABITAT FORMING SPECIES: WHAT IS HIDDEN BEHIND DENSE FORESTS OF *SARGASSUM MUTICUM*?



Pictures p. 149 Invasive species in the Wadden Sea. Top: thallus of *Sargassum muticum* (Japanese wireweed) aside *Crassostrea gigas* (Pacific oyster); Bottom: *Caprella mutica* (Japanese skeleton shrimp)

Source and copyright: Christian Buschbaum

CHAPTER IV. INTERNAL PROCESSES OF A HABITAT FORMING SPECIES: WHAT IS HIDDEN BEHIND DENSE FORESTS OF *SARGASSUM MUTICUM*?

Moritz Pockberger^{*}, Florian Kellnreitner, Niels Reinecke, Ragnhild Asmus, Harald Asmus

Alfred Wegener Institute, Helmholtz Centre for Polar and Marine Research, Wadden Sea Station Sylt, Hafenstrasse 43, D-25992 List, Germany

* corresponding author: moritz.pockberger@awi.de

Abstract

The brown algae *Sargassum muticum* is a successful invader, forming dense algal forests. These new habitats are suitable for other invaders such as the highly abundant amphipod *Caprella mutica*. For both species impacts and effects on native species are described, but little is known about internal processes of the dense *Sargassum* canopies and the effect of *C. mutica* on trophic interactions. In the present investigation routines of Ecological Network Analyses (ENA) were employed to calculate transport and cycling of material, as well as trophic interactions. Direct and indirect trophic interactions between the invasive *C. mutica* and native species were revealed. Out of samplings conducted inside the *S. muticum* forest a food web comprising 33 components was constructed. Indices to describe the system, such as the relative ascendancy (0.44) and relative redundancy (0.23), were calculated evaluating the system as organised with complex structures, but only few parallel pathways. According to average path length, material passed through 2.21 components before leaving the habitat, which came along with short cycles of energy as 97.28% were cycled by 2 or 3 components. Consider the impacts of *C. mutica* more positive than negative effects on native species could be observed. In conclusion the system might provide a suitable new habitat for native species, due to a rich habitat structure and plentiful energy resources.

Key words

Sargassum muticum, *Caprella mutica*, Ecological Network Analyses, Netwrk 4.2, invasive species, bioengineer

1. Introduction

Ecological Network Analysis (ENA) is a useful package of methods to depict ongoing developments and changes in ecosystems, especially food webs, and help to analyse possible consequences of transformations (Coll and Libralato, 2012), e.g. changing trophic interactions due to the loss or immigration of species. The analysis of a food web illustrates the interactions between the various components and allocates the size and direction of direct and indirect energy flows (Heymans et al., 2007; Libralato et al., 2006). In the present investigation ENA is applied to calculate the energy flows inside a newly established algal habitat formed by a bioengineer species.

The algae *Sargassum muticum* (Japanese wireweed) originates from Japan (Yendo, 1907) and spread in Europe after the introduction of *Crassostrea gigas* (Pacific oyster). The Pacific oyster forms vast reefs, providing hard substratum for the algae (Druehl, 1973). *Sargassum muticum* is now found along European coasts. The thalli start to grow in spring, forming dense forests with thalli lengths up to 2 m in summer and they are detached from and drifting away in fall, leaving only a small disc shaped holdfast during winter (Buschbaum et al., 2012; Critchley et al., 1990a, 1990b; Fleckenstein, 2011; Reichert and Buchholz, 2006; Schories et al., 1997).

The impacts of these dense subtidal plant canopies on different taxa and ecosystem components have been intensively studied (Britton-Simmons, 2004; Buschbaum et al., 2006; Lang and Buschbaum, 2010; Polte and Buschbaum, 2008; Rueness, 1989; Sanchez and Fernandez, 2005; Stæhr et al., 2000; Tweedley et al., 2008; Viejo, 1999). Positive and

negative effects of *S. muticum* on native species have been identified. Not only biotic components may be impacted by the algae forest, abiotic parameters such as insolation into deeper water layers, temperature, current velocity and water circulation are affected by the density of thalli (Strong et al., 2006).

Bouma et al. (2009) stated that habitat forming species might provide new structured areas for a variety of organisms. Jones et al. (1997) concluded that the main effects of bioengineers can lead to increased species abundance. Bulleri et al. (2010) described alteration of species communities after the introduction of algae. The occurrence of bioengineers may not only alter habitat structures but also affect trophic interactions and the organisation of the food web (Reise, 2002). Experiments to investigate the impact of *S. muticum* on ecosystem level were conducted by Salvaterra et al. (2013), describing transformations of food webs and effects on ecosystem processes, such as primary production.

In the Wadden Sea, *S. muticum* forests provide habitats for other highly abundant invasive species as *Caprella mutica* (Buschbaum and Gutow, 2005). The amphipod *C. mutica* originates from the Siberian coast of the Japanese Sea and grows up to 35 mm, spending the entire lifecycle attached to substrate (Willis et al., 2004). Due to the larger body size than native amphipods, high abundances and sedentary lifestyle, *C. mutica* might be an easily accessible energy source for predators, but also a competitor for native species (Shucksmith et al., 2009). Baird et al. (2012) investigated the effect of abundant invasive species (*C. gigas* and the barnacle *Austrominus modestus*) inside an ecosystem, showing that high abundant species have a significant effect on ecosystem functions and energy transport. The authors concluded that the presence of *C. gigas* and *A. modestus* does not necessarily have a

negative impact, but if species abundances decrease suddenly the system becomes less organised, prone towards disturbances and instable.

In the present investigation, routines of ENA are employed to analyse network structures inside a *S. muticum* forest. The absence of holistic information on internal processes, such as energy transport, cycling of material, trophic interactions, organisation and structures of energy flows in this newly formed habitat lead to the formulation of the following goals:

1. to present an overview of standing stocks of various components participating in the energy flow and material transport inside the habitat.
2. to calculate system parameters and network indices, which reveal the structure and organisation of energy pathways.
3. to disclose the transport of energy through the food web, from primary producers to higher trophic levels.
4. to investigate interdependencies between an invasive abundant species (*C. mutica*) and native species, considering possible positive and negative direct and indirect relationships and impacts.

2. Materials & Methods

2.1. Study site

This study was conducted in the Sylt-Rømø bight (54° 52` - 55° 10`N, 8° 20` - 8° 40`E), which is situated between the islands of Sylt (Germany) and Rømø (Denmark) (Fig. 1a). The bight is a part of the Wadden Sea, which extends along the coast of the south-eastern North Sea reaching from the Netherlands to Denmark. The bight comprises an area of 404 km², including 135 km² of tidal flats (Asmus and Asmus, 2000). Two causeways connecting the islands with the mainland inhibit the movement of water around the islands and direct

exchange with adjacent tidal basins. Between the islands there is only one tidal inlet of 2 km width and 40 m depth (Bayerl and Köster, 1998). The tidal range is up to 2 m (Martens and Beusekom, 2008). A detailed description of the Sylt-Rømø bight and characteristics is given in Gätje and Reise (1998). During sampling mean water temperature was $17.7 \pm 2.0^\circ\text{C}$ and salinity 30.6 ± 0.4 . Study sites were situated in the shallow subtidal zone. Mean water depth ranged between 0.5 m at low tide to 2.5 m at high tide in *S. muticum* forests.

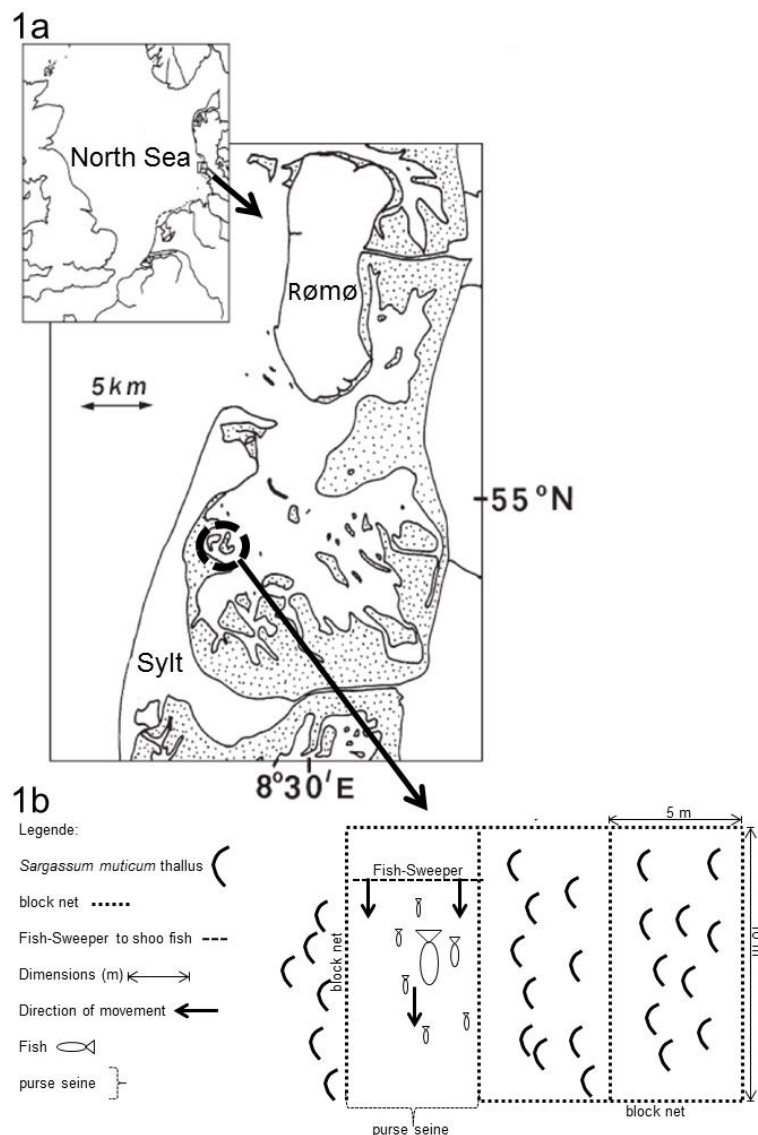

Fig.1a. Location of the sampling area (stippled circled area), between the islands of Sylt and Rømø in the North Sea, redrawn after (Asmus and Asmus, 2000). Fig 1b. Overview of the sampling method used to catch fish in *S. muticum* forest.

2.2. Sampling and laboratory analyses of fish

To investigate the abundance and feeding habits of fish, independent of their size, a block net sampling approach (Fig. 1b) was developed and set up in a *S. muticum* forest. Trapped fish were killed and preserved in 5% buffered formalin solution for further analyses.

In the laboratory, total length (TL) of individuals was measured to the nearest mm and wet weight (WW) was weighted to 0.01 g. Prey items found in digestive tracts were counted and defined to the highest taxonomical separation possible.

2.3. Sampling and laboratory analyses of meio- and macrofauna

To investigate the abundance of meio- and macrofauna in total 12 core samples were taken in *S. muticum* forest. Six meiofauna samples were taken using a sampler with a diameter of 20 mm, six macrofauna samples were collected using a sampler of 100 mm diameter. Samples were preserved in 5% buffered formalin solution. Additionally six randomly chosen *S. muticum* thalli were collected and transferred to the laboratory.

In the laboratory *S. muticum* thalli were rinsed with freshwater until all attached organisms were washed down. Samples were sieved (500 μm) and subsequently preserved again in 5% buffered formalin solution. Organisms were split into subsamples, identified and counted. Sediment samples were sieved through 250 μm and 1000 μm mesh nets, identified and counted. Organisms were dried to constant weight at 60 °C (DW) and incinerated at 500 °C to obtain ash free dry weight (AFDW). *Sargassum* thalli were dried at 60°C.

2.4. Data collection and calculation of parameters

To perform an ENA, the biomass, respiration, consumption, production, egestion and the diet composition of the different organisms of the food web are necessary. Abundance,

biomass and diet composition were sampled as described above. Data on abundance of *Sargassum* thalli were available from Fleckenstein (2011). Total biomass of *S. muticum* was calculated using the mean DW of thalli converted to mg carbon per m² (mg C m⁻²) employing the DW:C ratio by Wernberg et al. (2000). Gross primary production (GPP), net primary production (NPP) and respiration were estimated according to published results and ratios (Binzer et al., 2006; Pedersen et al., 2005). Necessary parameters for phytoplankton were obtained from the long term survey of the Wadden Sea station Sylt.

Biomass of sampled taxa was converted to mg C m⁻² using DW:C and AFDW:C ratios and further individual AFDW and C weights (Costantini and Rossi, 1995; Heerkloss and Vietinghoff, 1981; Herrmann et al., 1998; Kube, 1996; Reise et al., 1994).

Respiration, consumption, production and egestion (mg C m⁻² d⁻¹) of meio- and macrofauna were calculated according to Baird et al. (2007, 2004). When additional information was necessary the following literature was used: for *C. gigas* (Barillé et al., 1997; Bernard, 1974; Diederich et al., 2005; Jean and Thouzeau, 1995; Leguerrier et al., 2004, 2003), for *Caprella linearis* and *C. mutica* Vassilenko (1991). When no data was available, such as for *Apherusa* spp., *Jassa* spp., *Palaemon* sp., parameters of the nearest relative genus were employed (Baird et al., 2007, 2004). Data for *Carcinus maenas* was obtained from Palubitzki (2013). To complement information of dietary composition Kang et al. (1999); Decottignies et al. (2007); Baird et al. (2007), (2012); Boos (2009); Guerra-García and Figueroa (2009); Sturaro et al. (2010); Guerra-García et al. (2014) were consulted. Prey components such as microphytobenthos, free living and sediment bacteria, zooplankton, dissolved organic carbon (DOC), suspended and sediment particulate organic carbon (POC) were considered in addition. Necessary parameters of these components were taken from networks of adjacent subsystems in the Sylt-Rømø bight (Baird et al., 2007) and treated as imports.

The production of freeliving bacteria, phyto- and zooplankton, which was not consumed by other components of the food web, and egestion was supposed to turn into suspended POC. Excess production and egestion of other components was assumed to become sediment POC (Baird et al., 2007, 1998).

Parameters for fish species (*Anguilla anguilla*, *Spinachia spinachia*, *Syngnathus rostellatus*, *Zoarces viviparus*), not considered in previous studies, were calculated as followed:

A. First the daily growth for every individual of each fish species was calculated using growth parameters (Pauly, 1978; Leo and Gatto, 1995; Wiêcaszek, 1998) published on Fishbase following the von Bertalanffy growth equation (Eq. 1) (Sparre and Venema, 1998).

$$(\Delta L * \Delta t^{-1}) = K * (L_{\infty} - L(t)) \quad (1)$$

Eq. 1 gives the growth of an individual in cm year⁻¹ ($\Delta L * \Delta t^{-1}$), K presents the curvature parameter defining how fast a fish species approaches L_{∞} which is the asymptotic length or "the mean length of very old (strictly: infinitely old) individuals" (Sparre and Venema, 1998), $L(t)$ presents the length of the individual at a certain age.

B. In a second step the daily weight increase or production for each individual (Eq. 2) (Winberg, 1956; Norte-Campos, 1995), using Length-Weight relationships (Eq. 3), was estimated. For *A. anguilla* and *S. spinachia*, which were not abundant enough in the Sylt-Rømø bight, in 2010, to calculate a Length-Weight relationship, growth constants published on Fishbase (Froese and Pauly, 2010) were used (Bauchot and Bauchot, 1978; Simon, 2007).

$$\Delta B = [10^{d^{-1}} * (\log W_{t2} - \log W_{t1})] * 100 \quad (2)$$

Eq. 2 gives the daily increase ΔB of weight in percent, d gives the time interval in days, (W_{t2} the weight after 1 day - W_{t1} starting weight).

$$W = a * L^b \quad (3)$$

Eq. 3 gives the Length-Weight relationship, W represents weight in g, a and b are growth constants for each fish species, L represents the length in mm.

C. The third step implies the calculation of consumption rates. First the oxygen consumption for every individual was calculated and converted in g carbon per day employing published values on Fishbase (Altman and Dittmer, 1967; Bounhiol, 1905; Thurston and Gehrke, 1993; Winberg, 1956). Consumption rates were calculated following Herrmann et al. (1998) taking into account the abundances of different size classes of individuals (Eq. 4).

$$C = 1 * A^{-1} (\Delta B + R) \quad (4)$$

Eq. 4 gives the consumption C , A = the absorption coefficient of 0.8 (Herrmann et al., 1998; Winberg, 1956).

The consumption of the different prey components was calculated using the total consumption of a fish species multiplied by the percentage of each prey component found in analysed stomachs. Because all caught specimens of *A. anguilla*, *P. flesus* and *P. platessa* had empty stomachs, information of feeding preference and diet composition was obtained from previous diet analyses in the Sylt-Rømø bight (Kellnreitner et al. 2012) and from other literature (Costa et al., 1992).

2.5. ENA calculations and Lindeman spine

As mentioned above the present food web is based on the biomass, imports, exports, respiration and the flow of carbon ($\text{mg C m}^{-2} \text{ day}^{-1}$) between the components and constituted using ENA. Parameters such as biomass, consumption, production, respiration and egestion were mass balanced, the network was analysed at a non-steady state. To

calculate the amount of C exchanged between the abiotic and biotic components included in the food web, the software NETWRK 4.2c (Ulanowicz and Kay, 1991; Ulanowicz et al., 2005) was applied.

2.6. System attributes, network indices and cycling distribution

To characterise the system, indices giving information on important system attributes were calculated. A summary of the names, acronyms, meaning and interpretation of these indices according to relative literature is presented in Table 1. The distribution and circulation of energy among the different levels of a food web can be revealed using the routine "CYCLES" of NETWRK 4.2c (Ulanowicz et al., 2005). Indices characterising the cycling of material and energy are presented and explained in Table 1.

Lindeman spine

The Lindeman spine is a simplified presentation of a food web, converting a complex network with multiple pathways of trophic interactions into a linear food chain with discrete trophic levels. The parameters imports, exports, respiration, amount of energy passed to the next levels and the returns to the detrital pool of each trophic level are shown. The Lindeman spine gives a quantification of the efficiency and the amount of energy transferred in a system (Baird et al., 2004; Wulff et al., 1989). The definition of trophic efficiency can be explained as the percentage ratio between input and output of a trophic level (Wulff et al., 1989).

Table 1. Names, acronyms, meanings and interpretation of system attributes, network indices and indices of material cycling. No formulas are given for indices calculated by NETWORK 4.2c, these can be found in the relative literature.

System attributes	Computation (Unit)	Meaning	Interpretation	Literature
Number of components	-	Gives the number of living and dead system components.	More components indicate a more detailed network.	-
Trophic efficiency (TE)	geometric mean of TE of trophic levels (%)	Efficiency of energy transfer between trophic levels.	High values indicate higher efficiencies, more energy passes to higher trophic levels.	Baird et al. (2007)
Herbivory	$\text{mg C m}^{-2} \text{ d}^{-1}$	Measure for the dependency of live plant material.	Gives source and amount of energy transferred from the first (plant part) to the second trophic level.	Baird et al. (2007)
Detritivory	$\text{mg C m}^{-2} \text{ d}^{-1}$	Measure for the dependency of dead plant material.	Gives source and amount of energy transferred from the first (detrital part) to the second trophic level.	Baird et al. (2007)
Detritivory:Herbivory ratio	$\frac{\sum \text{Detritivory}}{\sum \text{Herbivory}}^{-1}$	Ratio of detritivory to herbivory.	Indicates the proportion of herbivore and detritivore components in a system.	Baird et al. (1998)
Development Capacity (DC)	$\text{mg C m}^{-2} \text{ d}^{-1}$	Upper bond of Ascendency.	Measure the networks potential to develop.	Baird et al. (1998)
Internal Development Capacity (DCi)	$\text{mg C m}^{-2} \text{ d}^{-1}$	Upper bond of internal Ascendency.	Measure the networks potential to develop considering only internal energy flows.	Baird et al. (1998)
Total System Throughput (TSTP)	$\text{mg C m}^{-2} \text{ d}^{-1}$	Sum of all flows.	Measure for the activity and size of a system.	Odum and Barrett (1971), Baird et al. (1998)
Flow Diversity or normalised Development Capacity (norm DC)	$(\text{DC} \times \text{TSTP}^{-1})$	Measure for the interactions in a system.	Similar to species richness, interactions increase in mature systems. High values for organised, developed systems;	Mann et al. (1989), Baird et al. (1998)
Average path length (APL)	$((\text{APL} = \text{TSTP} - Z) \times Z^{-1})$	Average number of components a unit	More components are passed in systems with high flow diversity and cycling.	Christensen (1995), Baird et al. (1998)
Average residence time (ART)	$\frac{\sum (\text{Biomass} \times \sum (\text{Exports} + \text{Respirations}))}{\text{Respirations}}$ (days)	Average time a unit of energy stays in the system.	Higher values indicate mature and more developed systems.	Christensen (1995)
Ascendency (A)	$\text{mg C m}^{-2} \text{ d}^{-1}$	Gives the size and organisation of a system.	Ascendency increases as a system matures and develops;	Ulanowicz (1986), Kay et al. (1989), Baird et al. (1998)
Relative Ascendency (rel A)	$(A \times \text{DC}^{-1})$ (%)	System organisation and efficiency of flows.	Higher values indicate higher resistance against disturbances.	Ulanowicz (1986), Mann et al. (1989), Baird et al. (1998)
Average mutual information or normal Ascendency (norm A)	$(A \times \text{TSTP}^{-1})$	Indicates development status of a system divided by TSTP to uncouple the effect of TSTP.	Increased AMI values in organised developed systems with high specialisation. Lower values indicate less productivity.	Baird and Ulanowicz (1989), Ulanowicz (2004)

Internal Ascendancy (Ai)	$\text{mg C m}^{-2} \text{d}^{-1}$	As Ascendancy, but considering internal flow of energy.	Ulanowicz (1986), Mann et al. (1989), Baird et al. (1998)
Relative internal Ascendancy (rel Ai)	$(\text{Ai} \times \text{DCi}^{-1}) (\%)$	System organisation and efficiency of internal flows.	Ulanowicz (1986), Mann et al. (1989), Baird et al. (1998)
Average internal mutual information or normalised internal Ascendancy (norm Ai)	$(\text{Ai} \times \text{TSTP}^{-1})$	Measures internal organisation, evenness of energy flows, interactions between components.	Ulanowicz (1986)
Redundancy (R)	$\text{mg C m}^{-2} \text{d}^{-1}$	Measures parallel pathways for energy transfer.	Ulanowicz and Norden (1990)
relative Redundancy (rel R)	$(\text{R} \times \text{DCi}^{-1}) (\%)$	Measures systems resilience towards disturbances.	Wulff et al. (1989), Christian et al. (2005)
normalised Redundancy	$(\text{R} \times \text{TSTP}^{-1})$	Difference between realised structure and upper bond, but divided by TSTP to uncouple the effect of TSTP.	Rutledge et al. (1976), Christensen (1995)
Internal Redundancy (Ri)	$\text{mg C m}^{-2} \text{d}^{-1}$	Measures the amount of energy bound in internal parallel pathways.	Rutledge et al. (1976), Baird et al. (1998)
Normalised internal Redundancy (norm Ri)	$(\text{Ri} \times \text{TSTP}^{-1})$	Difference between realised structure and upper bond, considering only internal flows, divided by TSTP to uncouple the effect of TSTP.	Rutledge et al. (1976), Baird and Ulanowicz (1989), Christensen (1995)
Dissipative Overhead (OD)	$\text{mg C m}^{-2} \text{d}^{-1}$	Measure for free or unbound energy in a system due to Respiration.	Kay et al. (1989), Ulanowicz and Norden (1990)
Overhead on Exports (OE)	$\text{mg C m}^{-2} \text{d}^{-1}$	Measure for free or unbound energy in a system due to Exports.	Kay et al. (1989), Ulanowicz and Norden (1990);
Overhead on Imports (OI)	$\text{mg C m}^{-2} \text{d}^{-1}$	Measure for free or unbound energy in a system due to Imports.	Kay et al. (1989), Ulanowicz and Norden (1990)
Normalised Overhead Φ	$\Sigma(\text{OD} + \text{OE} + \text{OI}) \times \text{TSTP}^{-1}$	Energy which is not bound in organised pathways. Contrary to Ascendancy.	Ulanowicz (2000)
System Overhead	$(\text{DC}-\text{A}) \text{ mg C m}^{-2} \text{d}^{-2}$	Measures total energy free or unbound in a system	(Baird et al., 2004; Bodini and Bondavalli, 2002)

Foodweb Connectance	-	Number of connections between two living components	Higher values indicate more interactions and complex systems.	Ulanowicz (1997), Baird et al. (1998)
Intercompartmental Connectance	-	Number of connections between two components excluding external flows	Higher values indicate more interactions and complex systems.	Ulanowicz (1997), Baird et al. (1998)
Overall Connectance	-	Number of connections between two components including external flows	Higher values indicate more interactions and complex systems.	Ulanowicz (1997), Baird et al. (1998)
Cycling indices				
Number of cycles	-	Circulation of energy beginning and ending in the same component, gives information on the structure of the system	High values indicate more complex systems	Baird et al. (1998), (2004), Baird (2012b)
Finn Cycling Index (FCI)	(%)	Percentage of TST that is recycled	Higher values indicate more mature and less stressed a system	Odum (1969), Finn (1976)

Effects of Caprella mutica

To estimate the possible influence of *C. mutica* on other components of the food web, the routine "IMPACTS" of NETWRK 4.2c (Ulanowicz and Puccia, 1990; Ulanowicz et al., 2005) were applied. This analysis shows the impact of one component on others and allows the evaluation of trophic interactions. The advantage of this routine is that direct as well as indirect interactions between the components of a food web are revealed (Ulanowicz and Puccia, 1990).

3. Results

3.1. Network assembly

In total 33 components were considered in the ENA of a *S. muticum* forest. Measured and calculated parameters used for the analyses give information on the standing stock, energy demand and uptake for autotrophs, heterotrophs and detritus (Table 2).

The input data to calculate the network, including biomass, imports, exports, respiration and trophic interactions in $\text{mg C m}^{-2} \text{d}^{-1}$ of each component, employed to perform further calculations and analyses are available in the format SCOR, suggested by the Committee for Oceanographic Research, in the Appendix, Supplement 3.

Dietary analyses revealed only a small amount ($68.05 \text{ mg C m}^{-2} \text{d}^{-1}$) of the NPP ($1101.60 \text{ mg C m}^{-2} \text{d}^{-1}$) of *S. muticum* (Table 2) was consumed by herbivore or grazing components, excess production ($1033.55 \text{ mg C m}^{-2} \text{d}^{-1}$) was considered to be exported out of the system.

The effective trophic levels for each food web component could be calculated because all trophic interactions of the considered components within the *Sargassum* forest were examined. The effective TL represents the sum of proportions of the diet consumed in different levels. Autotrophs, primary producers and non-living material are assigned to level

1. For the present food web effective TL of the majority of components was found to be below 3 (Table 2). Calculations assigned fish species, except *Pomatoschistus microps* (2.99) above level 3, with highest values for *Myoxocephalus scorpius* (3.26) and *Anguilla anguilla* (3.82) (Table 2). Values in brackets give effective TL.

Table 2. Numbers, names, effective trophic levels (TL), biomasses (mg C m⁻²), gross primary production (GPP), net primary production (NPP), consumption (C), production (P), respiration (R) and egestion (E) (mg C m⁻² d⁻¹) of autotrophs, heterotrophs and non-living components of the network analyses.

Comp no	Autotrophs	effective TL	Biomass	GPP	NPP	Respiration	
1	Phytoplankton	1.00	1093.00	376.43	323.20	53.23	
2	Mikrophytobenthos	1.00	2587.85	1287.26	606.46	680.80	
3	<i>Sargassum muticum</i>	1.00	511650.00	1530.00	1101.60	428.40	
	Heterotrophs		Biomass	C	P	R	E
4	freeliving bacteria	2.00	9.80	152.20	76.10	70.50	5.60
5	sediment bacteria	2.00	625.00	381.50	121.50	192.60	67.40
6	Zooplankton	2.00	11.20	4.60	1.50	0.40	2.70
7	Meiobenthos	2.00	6845.45	981.64	150.60	570.91	260.13
8	<i>Crassostrea gigas</i>	2.04	94500.00	452.87	95.79	335.02	22.05
9	<i>Cerastoderma</i> sp.	2.33	16890.83	420.81	84.16	26.38	310.27
10	<i>Mya</i> sp.	2.01	15397.29	168.29	33.65	78.29	56.35
11	<i>Lanice</i> sp.	2.01	1.31	0.03	6.80x10 ⁻³	0.01	0.01
12	Nereidae	2.56	1.97	0.09	5.64x10 ⁻³	0.02	0.06
13	<i>Apherusa</i> spp.	2.02	1478.96	60.48	8.25	39.02	13.21
14	<i>Corophium</i> spp.	2.12	1756.07	50.00	7.29	34.38	8.33
15	<i>Gammarus</i> spp.	2.06	205.79	8.42	1.15	5.43	1.84
16	<i>Caprella linearis</i>	2.08	343.36	7.02	0.96	4.53	1.53
17	<i>Caprella mutica</i>	2.08	355.08	7.26	0.99	4.68	1.59
18	<i>Jassa</i> spp.	2.00	103.62	2.75	0.41	1.77	0.56
19	<i>Idotea</i> spp.	2.25	137.65	3.65	0.55	2.35	0.74
20	<i>Palemon</i> sp.	3.12	1.70	0.10	0.02	0.06	0.02
21	<i>Crangon crangon</i>	3.12	3919.12	234.12	43.03	148.06	43.03
22	<i>Carcinus maenas</i>	3.12	9.49	0.23	0.04	0.06	0.13
23	<i>Pomatoschistus microps</i>	2.99	28.15	6.29	0.31	0.63	5.35
24	<i>Spinachia spinachia</i>	3.06	0.65	0.14	0.01	6.60x10 ⁻⁶	0.13
25	<i>Syngnathus rostellatus</i>	3.05	0.13	0.03	7.48x10 ⁻⁴	1.26x10 ⁻⁶	0.02
26	<i>Pleuronectes platessa</i>	3.05	3.97	0.19	0.03	0.04	0.12
27	<i>Platichthys flesus</i>	3.11	4.00	6.00	2.00	2.00	2.00
28	<i>Zoarces viviparus</i>	3.02	2.27	0.82	0.03	0.09	0.71
29	<i>Myoxocephalus scorpius</i>	3.26	3.01	0.09	0.02	0.05	0.03
30	<i>Anguilla anguilla</i>	3.82	40.74	1.82	0.05	0.97	0.81
	Detritus/non-living						
31	DOC	1.00	-	-	-	-	-
32	suspended POC	1.00	-	-	-	-	-

33	sediment POC	1.00	201.66	-	-	-	-
----	--------------	------	--------	---	---	---	---

3.2. System attributes, network indices and cycling distribution

Calculated system attributes estimated the trophic efficiency, a measure how efficient energy is transported within the system, at 1.57% (Table 3). Additional results might hint to a system in which energy transport to higher trophic levels depends on non-living material or detritus, as the detrivory to herbivory ratio is 1.58 to 1 (Table 3).

Network indices evaluate the amount of energy passing through the system and several measures how energy transport and pathways are organised inside the system. In the following passage important indices are described and calculated values are given in brackets. All calculated indices are presented in Table 3.

The total system throughput ($11500 \text{ mg C m}^{-2} \text{ d}^{-1}$), gives a measure for the size of the system. The ascendancy ($23848 \text{ mg C m}^{-2} \text{ d}^{-1}$) and redundancy ($12301 \text{ mg C m}^{-2} \text{ d}^{-1}$) provide values for the amount of energy transported in complex structures and parallel pathways (Table 3). The development capacity ($54603 \text{ mg C m}^{-2} \text{ d}^{-1}$) can be regarded as the upper limit of system growth (Table 3). Employing these four “basic” indices, derivatives such as relative ascendancy (0.44 or 44%) and relative redundancy (0.23 or 23%) can be calculated (Table 3) (For the relation between indices Table 1 may be considered). These derivatives indicate that 44% of the energy in the *S. muticum* forest is bound in structured energy flows and 23% in multiple pathways. As ascendancy and redundancy are strongly influenced by the amount of total system throughput the average mutual information (1.06) and normalised redundancy (1.07) (Table 3) are calculated. Calculated values indicate that the system can be considered as being organised with complex structures, but only a small portion of energy is transported via parallel pathways (Table 3).

The system overhead (18454.71 mg C m⁻² d⁻¹) and normalised overhead (1.60) (Table 3) give the amount of energy which is not organised, or in other words, “used” by components in the *Sargassum* forest. The overhead provides a buffer against disturbances, as this amount of energy may be ingested and transported within the food web, when common energy resources and pathways, bound in organised structures, are disturbed.

The average path length (2.21), the flow diversity (4.75) and the average residence time (168) illustrate trophic structures, the evenness of energy flows and the numbers of trophic interactions (Table 3). These indices point out that in *Sargassum* forests energy coming into the system passes at least through two components before leaving the system. Higher values of path length are considered to accompany higher values of flow diversity indicating more interactions and an even distribution of energy flow in the system. The average residence time gives a measure for the retentive capacity, as the number of days is calculated for a unit of energy, such as carbon, to persist inside the *S. muticum* canopy. If carbon persists for a period of time inside a system it may be recycled while passing through the food web. The Finn cycling index (11.24%) depicts a measure how much energy of the total system throughput is recycled (Table 3). The cycling distribution (Table 4) shows that carbon can be cycled through up to 10 components, but the majority of energy (97.28%) is processed by 2 or 3 components. The major amount (58.05%) cycled through two components implies meiobenthos and sediment POC, followed by sediment bacteria and sediment POC (29.82%), further meiobenthos and *Crangon crangon* (8.97%).

Table 3. System attributes, network indices and indices of material cycling in *S. muticum* forest.

Name	Value
System attributes	
Number of components	33
System trophic efficiency	1.57
Herbivory	981
Detrivory	1549.60
Detrivory:Herbivory ratio	1.58:1
Network Indices	
Development Capacity	54603.00
internal Development Capacity	24481.00
Total System Throughput	11500.00
Flow Diversity	4.75
Average path length	2.21
Average residence time	168
Ascendency	23848.00
Relative Ascendency	0.44
Avarege mutual information	1.06
Internal Ascendency	12180
Relative internal Ascendency	0.52
Avarege internal mutual information	1.11
Redundancy	12301.00
relative Redundancy	0.23
normalised Redundancy	1.07
Internal Redundancy	12301
Normalised internal Redundancy	1.07
Dissipative Overhead	10907.00
Overhead on Exports	584.91
Overhead on Imports	6962.80
Normalised Overhead	1.60
System Overhead	18454.71
Foodweb Connectance	2.07
Intercompertmental Connectance	2.24
Overall Connectance	1.80
Cycling indices	
Number of cycles	2813
Finn Cycling Index	11.24

Table 4. Number of components or the path length of cycled energy, the amount ($\text{mg C m}^{-2} \text{d}^{-1}$) and the proportion (%) of cycled material are given.

Path length	Cycled material	Portion in %
1	0.00	0.00
2	1080	83.25
3	182	14.03
4	30.10	2.32
5	4.52	0.35
6	0.67	0.05
7	4.36×10^{-3}	3.36×10^{-4}
8	2.82×10^{-5}	2.17×10^{-6}
9	9.69×10^{-8}	7.47×10^{-9}
10	3.22×10^{-13}	2.48×10^{-14}
Total	2810	100

3.3. Lindeman Spine

The transport of energy through different trophic levels is revealed by the Lindeman spine (Fig. 2). Although the majority of the energy, imported into the system, is used by the first three trophic levels, in total energy is transferred up to trophic level eight. Around 53% of the whole energy imported into the system was used by the first trophic level. As thalli of *S. muticum* are drifting away at the end of the vegetation period, high exports from the first trophic level can be observed. Major imports into the second trophic level originate from detritus. In trophic level two respiration is responsible for the major part of exports, which seem to cause low trophic efficiencies and low energy transport to higher levels.

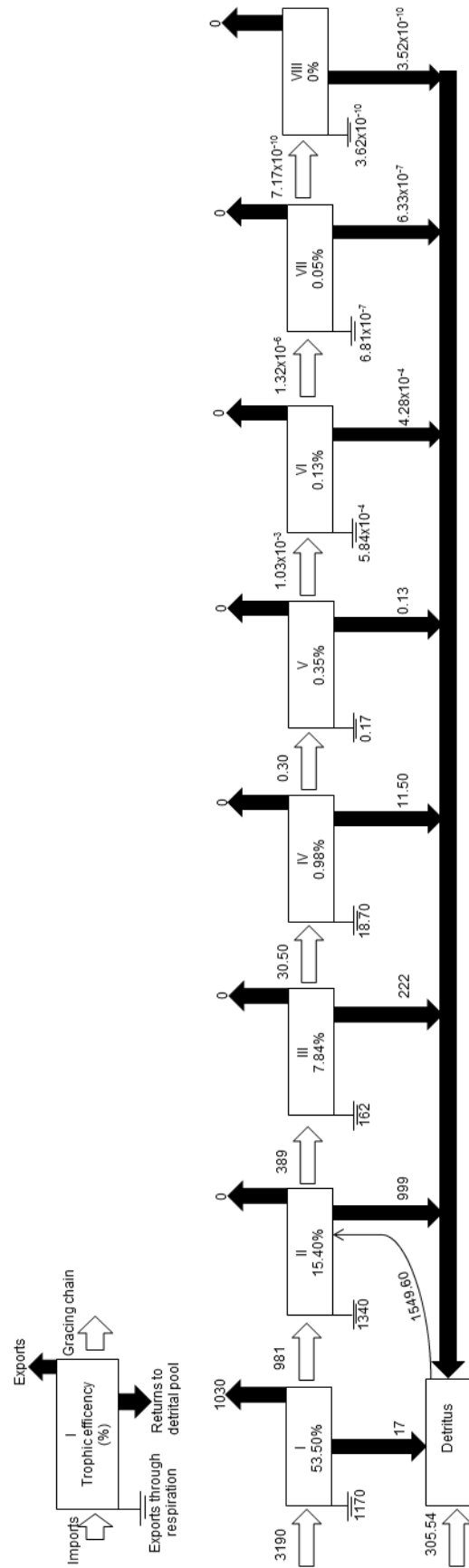

Fig. 2. Lindeman spines for *S. muticum* forest. Roman numbers indicate trophic level, arrow from Detritus to second trophic level shows detritivory. Values, except trophic efficiency, in mg C m⁻² d⁻¹.

3.4. Effects of *Caprella mutica* as impacting component

Caprella mutica ranked third comparing the biomass of the amphipods (355.08 mg C m⁻²) (Table 2). *C. mutica* was frequently found in the diet of fish. Impact analyses reveal that *C. mutica* has a positive effect on native fish species (e.g. *Myoxocephalus scorpius*, *Syngnathus rostellatus*, *Spinachia spinachia*) (Fig. 3a). Negative impacts of *C. mutica* are smaller, compared to positive impacts, and seem to affect mainly competitors for food (*Jassa* spp., *C. mutica*, *Caprella linearis*, *Carcinus maenas*) and prey components (zooplankton) (Fig. 3a).

3.5. Effects on *C. mutica* as impacted component

Only a few positive effects on *C. mutica* can be found in the impact analysis, mainly via energy resources (suspended POC). Indirect trophic interactions are also observed (e.g. *Platichthys flesus*) (Fig. 3b). Negative impacts on *C. mutica* are numerous, mainly by predators (*C. crangon*) and components competing for food and energy resources (*Crassostrea gigas*, *Cerastoderma* sp.), but also by components effecting *C. mutica* indirectly (e.g. microphytobenthos) (Fig 3b).

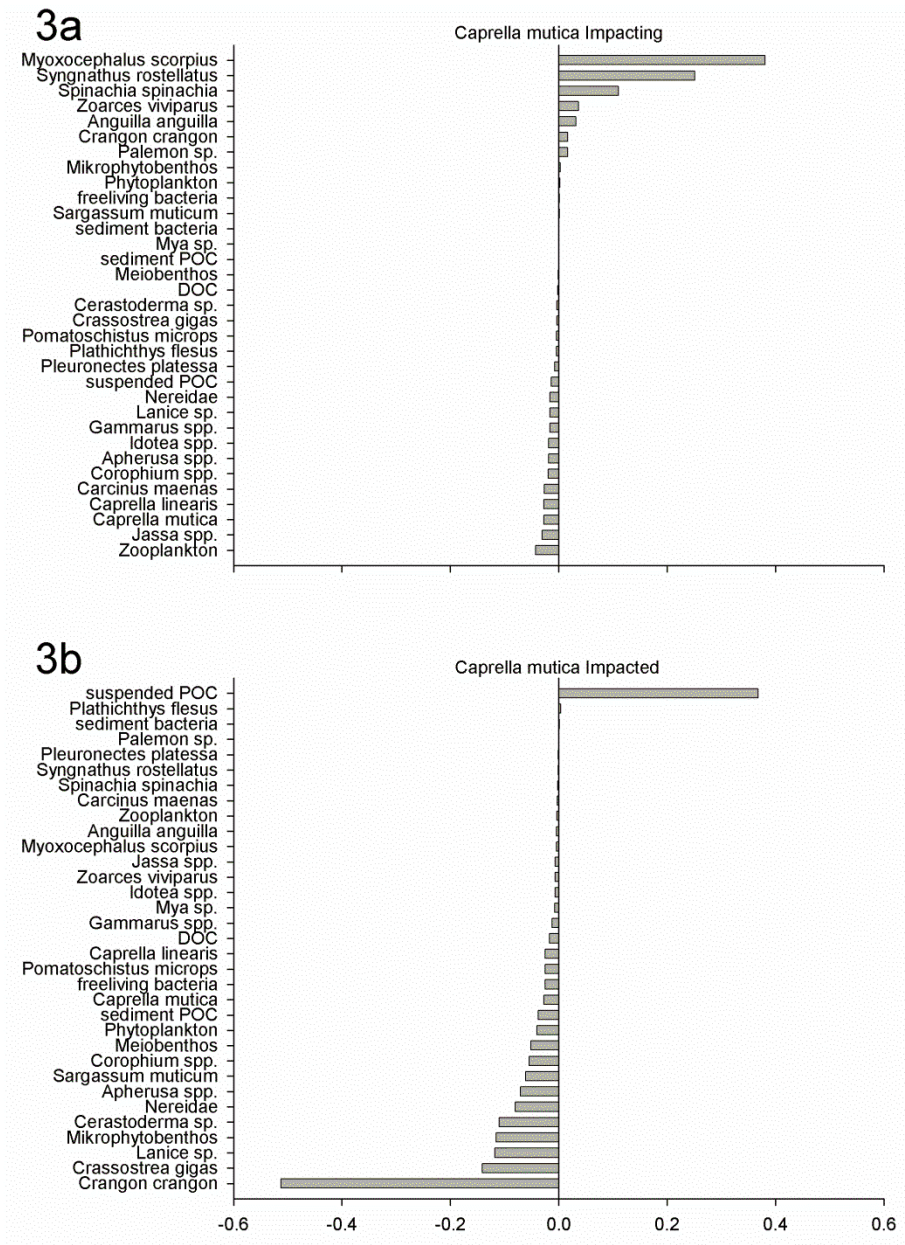

Fig. 3a. Impacts by *C. mutica* in the food web on other components. Fig. 3b Impacts of other components on *C. mutica*.

4. Discussion

4.1. Network assembly

The present network analysis reveals the energy flow and trophic interactions in a newly formed habitat. The import of additional components reflects the transport of materials by water movement, as most marine habitats are open systems depending on the exchange with adjacent habitats (Asmus and Asmus, 2000, 1998; Baird et al., 2007; Beusekom et al., 2012). Results of calculated effective trophic levels for invertebrates are in concordance with previous network analyses conducted in the Sylt-Rømø bight (Baird et al., 2004). Efficient trophic levels of fish species differ from former investigations (Baird et al., 2004; Kellnreitner, 2012) probably due to the high abundance of juvenile individuals. For *P. microps* an effective trophic level below 3 was calculated. Kellnreitner (2012) and Pockberger et al. (2014) investigated the trophic position of *P. microps* in the Sylt-Rømø bight and described trophic levels above 3. In both investigations juvenile and adult individuals were considered, whereas in the present investigation mainly juveniles, feeding mostly on zooplankton, were caught.

The trophic network was calculated in a non-steady or unbalanced state (Baird et al., 2007). The inequality of system imports and exports might be caused by excessive use of certain prey components, which cannot be balanced by production (Baird et al., 2007). Calculating and analysing the system in an unbalanced state follows Baird et al. (2009), who compared analyses of balanced and unbalanced systems concluding that balancing had distinct effects on ENA indices and results.

4.2. System attributes, network indices and cycling distribution

ENA indices are a good basis for system comparisons (Baird et al. 2004). Yet these comparisons have to be considered with care, as comparability depends on system organisation, on the time frame of observation and of cycled energy and the type of material (e.g. carbon, nitrogen or phosphor) (Christian et al., 2005). ENA indices such as relative ascendancy, average mutual information, relative redundancy and flow diversity are suggested as basis for the comparison of ecosystems (Christian et al., 2005; Wulff et al., 1989).

Salvaterra et al. (2013) observed different associations of native algae and the introduced *S. muticum*. They described significant effects on the primary production of native algae. The authors found a significantly increased food web connectance in the presence of *S. muticum*, accompanied by a trend of decreasing number of system components and diversity. Food web connectance is a measure for the energy exchange between living components, higher values indicate increased exchange rates (Ulanowicz, 1997).

Ecological network analyses of dense plant canopies in the Wadden Sea are rare. Thus the results are compared with investigations focusing on the dwarf eelgrass (*Zostera noltii*) (Baird et al., 2007). For seagrass beds lower values of relative ascendancy (36.7% to 39.5%) were found, compared to 44% (Table 2) for *Sargassum*. Seagrass beds showed higher values of the average mutual information index (1.72 to 1.83) and higher relative redundancy (34.5% to 37.5%), compared to 1.06 (Table 2) respectively 23% (Table 2) in the present analyses.

Ulanowicz (2003) and Patrício et al. (2004) described higher ascendancy values for more efficient, organised and mature systems. Christian et al. (2005) concluded that higher values of relative redundancy may indicate increased system stability through parallel energy

pathways. Following above assessments, the *Sargassum* forest seem to present a more organised but less stable system compared to seagrass beds. This is in accordance with the theory that well organised systems are less resilient against disturbances (Ulanowicz, 2000). The flow diversity is found to be higher (4.75) (Table 2) in the network analysis of *S. muticum*, compared to *Z. noltii* beds (4.63 to 4.70) (Baird et al., 2007). Higher values of flow diversity indicate a more even distribution of energy and increased trophic interactions. Higher values may be based on the large number of network components feeding on the same trophic level. Additionally the high abundance of omnivores feeding on various prey items in the *S. muticum* forests may further increase the flow diversity. On the other hand the high abundance of omnivores may also be reflected in the before mentioned comparable low values of average mutual information indicating the specialisation of flows (Ulanowicz, 2004).

Analyses comparing the impact of other algae, such as kelp systems, to areas without macroalgal cover, described again higher relative ascendancy values. Values indicate that kelp ecosystems are more mature and complex, but bare areas are less prone to disturbances (Ortiz, 2008).

4.3. Lindeman spine

The majority of energy inputs in the food web of *S. muticum* forests seemed to be used by primary production and further by consumers in trophic level two, and three. Trophic efficiencies may reflect the inefficient use and low impact of predators on plentiful food supplies, such as high biomass of algae for herbivores, further high abundances of amphipods for omnivore and carnivore predators. The excess of available but “unused” energy resources may also be responsible for high values of above presented system overheads.

Low trophic efficiencies may also be caused by the high abundance of larger mussels and oysters. Via respiration large amounts of energy are exported, whereas no predation on larger bivalves could be observed, which might indicate that these components represent a dead end in terms of energy flow. Other investigations in the Wadden Sea described positive effects of abundant *C. gigas*, forming structured habitats for meio- and macrofauna but these studies point out that energy flow to higher trophic levels may be restricted as predation on the invasive oyster is low (Markert et al., 2009; Reise, 1998; Smaal et al., 2005). A comparison between the systems of *S. muticum* and the food web of *Z. noltii* showed similarities as highest trophic efficiencies were observed for level two, followed by a steep decline in higher trophic levels (Baird et al., 2007). Other analogies may be found as the second trophic level seems to depend strongly on detritus import in dense seagrass beds (Baird et al., 2007) as well as in the *Sargassum* forest. This pattern of high effective trophic efficiency on lower trophic levels, a steep decline of efficiency in higher trophic levels and a strong dependency on detritus import is also found in other systems dominated by macrophytes (Jia et al., 2012; Ortiz, 2008).

4.4. Effects of *Caprella mutica*

Analysing the impacts of *C. mutica* on other system components shows that positive effects prevail compared to negative effects. Especially for native and threatened fish species, such as *Spinachia spinachia*, the invasive amphipod is, due to its sedentary life style, an easily accessible energy source. Only few negative impacts were found, indicating small effects on the system components. Regarding the impacts of system components on *C. mutica* indirect trophic interactions can be revealed. *Caprella mutica* seemed to benefit from preying of *P. flesus* on crustaceans (e.g. *C. crangon*), polychaetes and bivalves, as these invertebrates are

either predators or competitors for energy sources. Microphytobenthos in turn impacts *C. mutica* negatively as these algae provide energy to competitors of *C. mutica*.

Baird et al. (2012) studied the effects of two abundant species (*A. modestus*, *C. gigas*) on system organisation and concluded that invasive species might control energy flow by high abundance. The authors further stated that as long as these species are present, a system might not be endangered, but if abundance declines the stability of energy flows and the organisation of the system can be influenced.

Several studies describe *C. mutica* as a tolerant species invading successfully different habitats in many geographic regions and emphasise that *C. mutica* is competing strongly with native amphipods (Ashton et al., 2007, 2008; Cook et al., 2007a, 2007b; Schückel et al., 2010; Shucksmith et al., 2009; Willis et al., 2004). During this investigation *C. mutica* was found abundant in the diet of fish and at third place regarding biomass in the algal forest. Considering above publications, this invasive species might outcompete native amphipods and become an important link in the energy flow.

Regarding higher trophic levels the establishment of the new species might be less adverse on first sight. In marine areas predominated by soft sediments, structured habitats are mostly formed by habitat generating species, such as reef forming bivalves and subtidal plant canopies (Polte et al., 2005; Reise, 2005). Viejo (1999) and Markert et al. (2009) described increasing abundances and biomasses of meio- and macrofauna, following the invasion of *C. gigas* and *S. muticum*, by increased habitat complexity. For native predators, such as fish, results indicate that the combination of a new complex habitat, *S. muticum* forests, and easy accessible prey, *C. mutica*, provided by invasive species seems to be beneficial.

Acknowledgments

We are deeply thankful to Birgit Hussel who participated and helped during field work and in addition for her technical assistance given at the different stages of this investigation. We are grateful to Anna Broich and Tim Katzenberger for their assistance with sampling meio-, macrofauna and fish.

References Chapter IV

- Altman, L.P., Dittmer, D.S., 1967. Environmental Biology, The Journal of Wildlife Management. Federation of American Societies for Experimental Biology, Bethesda, Maryland. doi:10.2307/3798346
- Ashton, G., Willis, K.J., Cook, E.J., Burrows, M., 2007. Distribution of the introduced amphipod, *Caprella mutica* Schurin, 1935 (Amphipoda: Caprellida: Caprellidae) on the west coast of Scotland and a review of its global distribution. *Hydrobiologia* 590, 31–41.
- Ashton, G.V., Riedlecker, E.I., Ruiz, G.M., 2008. First non-native crustacean established in coastal waters of Alaska. *Aquat. Biol.* 3, 133–137. doi:10.3354/ab00070
- Asmus, H., Asmus, R., 1998. The role of macrobenthic communities for sediment-water material exchange in the Sylt-Rømø tidal basin. *Senckenbergiana maritima* 29, 111–119.
- Asmus, H., Asmus, R., 2000. Material exchange and food web of seagrass beds in the Sylt-Rømø bight: how significant are community changes at the ecosystem level? *Helgol. Mar. Res.* 54, 137–150.
- Baird, D., 2012. Assessment of observed and perceived changes in ecosystems over time, with special reference to the Sylt-Rømø bight, German Wadden Sea. *Estuar. Coast. Shelf Sci.* 108, 144–154. doi:10.1016/j.ecss.2011.06.006
- Baird, D., Asmus, H., Asmus, R., 2004. Energy flow of a boreal intertidal ecosystem, the Sylt-Rømø bight. *Mar. Ecol. Prog. Ser.* 279, 45–61. doi:10.3354/meps279045
- Baird, D., Asmus, H., Asmus, R., 2007. Trophic dynamics of eight intertidal communities of the Sylt-Rømø bight ecosystem, northern Wadden Sea. *Mar. Ecol. Prog. Ser.* 351, 25–41. doi:10.3354/meps07137
- Baird, D., Asmus, H., Asmus, R., 2012. Effect of invasive species on the structure and function of the Sylt-Rømø bight ecosystem, northern Wadden Sea, over three time periods. *Mar. Ecol. Prog. Ser.* 462, 143–161. doi:10.3354/meps09837
- Baird, D., Fath, B.D., Ulanowicz, R.E., Asmus, H., Asmus, R., 2009. On the consequences of aggregation and balancing of networks on system properties derived from ecological network analysis. *Ecol. Modell.* 220, 3465–3471. doi:10.1016/j.ecolmodel.2009.09.008
- Baird, D., Luckovich, J., Christian, R., 1998. Assessment of spatial and temporal variability in ecosystem attributes of the St Marks National wildlife refuge, Apalachee Bay, Florida.
- Baird, D., Ulanowicz, R.E., 1989. The seasonal dynamics of the Chesapeake Bay ecosystem. *Ecol. Monogr.* 59, 329–364.
- Barillé, L., Héral, M., Barillé-Boyer. Anne-Laure, 1997. Modélisation de l'écophysologie de l'huître *Crassostrea gigas* dans un environnement estuarien. *Aquat. Living Resour.* 31–48.

-
- Bauchot, R., Bauchot, M.L., 1978. Coefficient de condition et indice pondéral chez les téléostéens. *Cybium* 3–16.
- Bayerl, R., Köster, K., 1998. Morphodynamik des Lister Tidebeckens, in: Gätje, C., Reise, K. (Eds.), *Ökosystem Wattenmeer - Austausch-, Transport- Und Stoffumwandlungsprozesse*. Springer, Berlin, Heidelberg, New York, pp. 25–29.
- Bernard, F., 1974. Annual biodeposition and gross energy budget of mature Pacific oysters, *Crassostrea gigas*. *J. Fish. Board Canada* 31, 185–190.
- Beusekom, van J.E.E., Buschbaum, C., Reise, K., 2012. Wadden Sea tidal basins and the mediating role of the North Sea in ecological processes: scaling up of management? *Ocean Coast. Manag.* 68, 69–78. doi:10.1016/j.ocecoaman.2012.05.002
- Binzer, T., Sand-Jensen, K., Middelboe, A.-L., 2006. Community photosynthesis of aquatic macrophytes. *Limnol. Oceanogr.* 51, 2722–2733. doi:10.4319/lo.2006.51.6.2722
- Bodini, A., Bondavalli, C., 2002. Towards a sustainable use of water resources: a whole-ecosystem approach using network analysis. *Int. J. Environ. Pollut.* 18, 463–485.
- Boos, K., 2009. Mechanisms of a successful immigration from north-east Asia: population dynamics , life history traits and interspecific interactions in the caprellid amphipod *Caprella mutica* Schurin , 1935 (Crustacea , Amphipoda) in European coastal waters. Freie Universität Berlin.
- Bouma, T.J., Olenin, S., Reise, K., Ysebaert, T., 2009. Ecosystem engineering and biodiversity in coastal sediments: posing hypotheses. *Helgol. Mar. Res.* 63, 95–106. doi:10.1007/s10152-009-0146-y
- Bounhiol, J.P., 1905. Experimental studies in aquatic respiration, Respiration of fish. *Bull. Sci. la Fr. la Belgique* 277–305.
- Britton-Simmons, K., 2004. Direct and indirect effects of the introduced alga *Sargassum muticum* on benthic, subtidal communities of Washington State, USA. *Mar. Ecol. Prog. Ser.* 277, 61–78.
- Bulleri, F., Balata, D., Bertocci, I., Tamburello, L., Benedetti-Cecchi, L., 2010. The seaweed *Caulerpa racemosa* on Mediterranean rocky reefs : from passenger to driver of ecological change. *Ecology* 91, 2205–2212.
- Buschbaum, C., Chapman, A.S., Saier, B., 2006. How an introduced seaweed can affect epibiota diversity in different coastal systems. *Mar. Biol.* 148, 143–161. doi:10.1007/s00227-005-0128-9
- Buschbaum, C., Gutow, L., 2005. Mass occurrence of an introduced crustacean (*Caprella* cf. *mutica*) in the south-eastern North Sea. *Helgol. Mar. Res.* 59, 252–253. doi:10.1007/s10152-005-0225-7

- Buschbaum, C., Lackschewitz, D., Reise, K., 2012. Nonnative macrobenthos in the Wadden Sea ecosystem. *Ocean Coast. Manag.* 68, 89–101. doi:10.1016/j.ocecoaman.2011.12.011
- Christensen, V., 1995. Ecosystem maturity - towards quantification. *Ecol. Modell.* 77, 3–32.
- Christian, R.R., Baird, D., Luczkovich, J., C, J.J., Scharler, U.M., Ulanowicz, R.E., 2005. Role of network analysis in comparative ecosystem ecology of estuaries, in: Belgrano, A., Scharler, U.M., Dunne, J., Ulanowicz, R.E. (Eds.), *Aquatic Food Webs and Ecosystem Approach*. Oxford University Press, Oxford, pp. 25–40.
- Coll, M., Libralato, S., 2012. Contributions of food web modelling to the ecosystem approach to marine resource management in the Mediterranean Sea. *Fish Fish.* 13, 60–88. doi:10.1111/j.1467-2979.2011.00420.x
- Cook, E.J., Jahnke, M., Kerckhof, F., Minchin, D., Faasse, M., Boos, K., Ashton, G., 2007. European expansion of the introduced amphipod *Caprella mutica* Schurin, 1935. *Aquat. Invasions* 2, 411–421. doi:10.3391/ai.2007.2.4.11
- Cook, E.J., Willis, K.J., Lozano-Fernandez, M., 2007. Survivorship, growth and reproduction of the non-native *Caprella mutica* Schurin, 1935 (Crustacea: Amphipoda). *Hydrobiologia* 590, 55–64. doi:10.1007/s10750-007-0757-8
- Costa, J.L., Assis, C.A., Almeida, P.R., Moreira, F.M., Costa, M.J., 1992. On the food of the European eel, *Anguilla anguilla* (L.), in the the upper zone of the Tagus estuary, Portugal. *J. Fish Biol.* 841–850.
- Costantini, M.L., Rossi, L., 1995. Role of fungal patchiness on vegetal detritus in the trophic interactions between two brackish detritivores, *Idotea baltica* and *Gammarus insensibilis*. *Hydrobiologia* 316, 117–126.
- Critchley, A.T., Farnham, W.F., Yoshida, T., Norton, T.A., 1990a. A bibliography of the invasive alga *Sargassum muticum* (Yendo) Fensholt (Fucales; Sargassaceae). *Bot. Mar.* 33, 551–562. doi:10.1515/botm.1990.33.6.551
- Critchley, A.T., Visscher, P.R.M., Nienhuis, P.H., 1990b. Canopy characteristics of the brown alga *Sargassum muticum* (Fucales, Phaeophyta) in lake Grevelingen, southwest Netherlands. *Hydrobiologia* 204-205, 211–217. doi:10.1007/BF00040236
- Decottignies, P., Beninger, P.G., Rincé, Y., Riera, P., 2007. Trophic interactions between two introduced suspension-feeders, *Crepidula fornicata* and *Crassostrea gigas*, are influenced by seasonal effects and qualitative selection capacity. *J. Exp. Mar. Bio. Ecol.* 342, 231–241. doi:10.1016/j.jembe.2006.10.005
- Diederich, S., Nehls, G., Beusekom, van J., Reise, K., 2005. Introduced Pacific oysters (*Crassostrea gigas*) in the northern Wadden Sea: invasion accelerated by warm summers? *Helgol. Mar. Res.* 59, 97–106. doi:10.1007/s10152-004-0195-1

-
- Druehl, L.D., 1973. Marine Transplantations. *Science* (80-). 179, 12.
- Finn, J., 1976. Measures of ecosystem structure and function derived from analysis of flows. *J. Theor. Biol.* 56, 363–380.
- Fleckenstein, N., 2011. The role of the immigrant *Caprella mutica* in coastal ecosystems of the German Bight. Carl von Ossietzky Universität, Oldenburg.
- Froese, R., Pauly, D., 2010. FishBase. <http://www.fishbase.org> (accessed 18 Aug 2014).
- Gätje, C., Reise, K., 1998. Ökosystem Wattenmeer - Austausch-, Transport- und Stoffumwandlungsprozesse. Springer, Berlin, Heidelberg, New York.
- Guerra-García, J.M., Tierno de Figueroa, J.M., 2009. What do caprellids (Crustacea: Amphipoda) feed on? *Mar. Biol.* 156, 1881–1890. doi:10.1007/s00227-009-1220-3
- Guerra-García, J.M., Tierno de Figueroa, J.M., Navarro-Barranco, C., Ros, M., Sánchez-Moyano, J.E., Moreira, J., 2014. Dietary analysis of the marine Amphipoda (Crustacea: Peracarida) from the Iberian Peninsula. *J. Sea Res.* 85, 508–517. doi:10.1016/j.seares.2013.08.006
- Heerkloss, R., Vietinghoff, U., 1981. Biomasseäquivalente planktischer und benthischer Organismen in den Darß-Zingster Boddengewässern. *Wissenschaftliche Zeitschrift der Univ. Rostock, Math. R.* 31–36.
- Herrmann, J.P., Jansen, S., Temming, A., 1998. Consumption of fish and decapod crustaceans and their role in the trophic relations of the Sylt-Rømø bight, in: Gätje, C., Reise, K. (Eds.), *Ökosystem Wattenmeer-Austausch-Transport- und Stoffumwandlungsprozesse*. Springer, Berlin-Heidelberg, pp. 437–462.
- Heymans, J.J., Guénette, S., Christensen, V., 2007. Evaluating Network Analysis indicators of ecosystem status in the gulf of Alaska. *Ecosystems* 10, 488–502. doi:10.1007/s10021-007-9034-y
- Jean, F., Thouzeau, G., 1995. Estimation des variables d'état d'un modèle de réseau trophique benthique en rade de Brest. *Comptes rendus l'Académie des Sci. Série 3, Sci. la vie* 318, 145–154.
- Jia, P., Hu, M., Hu, Z., Liu, Q., Wu, Z., 2012. Modeling trophic structure and energy flows in a typical macrophyte dominated shallow lake using the mass balanced model. *Ecol. Modell.* 233, 26–30. doi:10.1016/j.ecolmodel.2012.02.026
- Jones, C.G., Lawton, J.H., Shachak, M., 2013. Positive and negative effects of organisms as physical ecosystem engineers. *Ecology* 78, 1946–1957.

- Kang, C.K., Sauriau, P., Richard, P., Blanchard, G.F., 1999. Food sources of the infaunal suspension-feeding bivalve *Cerastoderma edule* in a muddy sandflat of Marennes-Oléron bay, as determined by analyses of carbon and nitrogen stable isotopes. *Mar. Ecol. Prog. Ser.* 187, 147–158.
- Kay, J., Graham, L., Ulanowicz, R., 1989. A detailed guide to network analysis, in: Wulff, F., Field, J., Mann, K. (Eds.), *Network Analysis in Marine Ecology Coastal and Estuarine Studies Series*. Springer-Verlag, Berlin, pp. 15–61.
- Kellnreitner, F., 2012. The trophic structure of a Wadden Sea fish community and its feeding interactions with alien species. Christian-Albrechts-University, Kiel.
- Kellnreitner, F., Pockberger, M., Asmus, H., 2012. Seasonal variation of assemblage and feeding guild structure of fish species in a boreal tidal basin. *Estuar. Coast. Shelf Sci.* 108, 97–108. doi:10.1016/j.ecss.2011.02.020
- Kube, J., 1996. Spatial and temporal variations in the population structure of the soft-shell clam *Mya arenaria* in the Pomeranian bay (Southern Baltic Sea). *J. Sea Res.* 35, 335–344.
- Lang, A.C., Buschbaum, C., 2010. Facilitative effects of introduced Pacific oysters on native macroalgae are limited by a secondary invader, the seaweed *Sargassum muticum*. *J. Sea Res.* 63, 119–128. doi:10.1016/j.seares.2009.11.002
- Leguerrier, D., Niquil, N., Boileau, N., Rzeznik, J., Sauriau, P., Le Moine, O., Bacher, C., 2003. Numerical analysis of the food web of an intertidal mudflat ecosystem on the Atlantic coast of France. *Mar. Ecol. Prog. Ser.* 246, 17–37. doi:10.3354/meps246017
- Leguerrier, D., Niquil, N., Petiau, A., Bodoy, A., 2004. Modeling the impact of oyster culture on a mudflat food web in Marennes-Oléron Bay (France). *Mar. Ecol. Prog. Ser.* 273, 147–162. doi:10.3354/meps273147
- Leo de, G.A., Gatto, M., 1995. A size and age-structured model of the European eel (*Anguilla anguilla* L.). *Can. J. Fish. Aquat. Sci.* 1351–1367.
- Libralato, S., Christensen, V., Pauly, D., 2006. A method for identifying keystone species in food web models. *Ecol. Modell.* 195, 153–171. doi:10.1016/j.ecolmodel.2005.11.029
- Mann, K., Field, J., Wulff, F., 1989. Network analysis in marine ecology: an assessment. *Coast. Estuar. Stud.* 32, 259–282.
- Markert, A., Wehrmann, A., Kröncke, I., 2009. Recently established *Crassostrea*-reefs versus native *Mytilus*-beds: differences in ecosystem engineering affects the macrofaunal communities (Wadden Sea of Lower Saxony, southern German Bight). *Biol. Invasions* 12, 15–32. doi:10.1007/s10530-009-9425-4
- Martens, P., Beusekom, van J.E.E., 2008. Zooplankton response to a warmer northern Wadden Sea. *Helgol. Mar. Res.* 62, 67–75. doi:10.1007/s10152-007-0097-0

-
- Norte-Campos del, A.G.C., 1995. Ecological studies on the coexistence of the brown shrimp *Crangon crangon* L and the gobies *Pomatoschistus microps* Krøyer and *P. minutus* Pallas in shallow areas of the German Wadden Sea. University of Hamburg.
- Odum, E.P., 1969. The strategy of ecosystem development. *Science* (80-). 164, 262–270.
- Odum, E.P., Barrett, G.W., 1971. *Fundamentals of ecology*.
- Ortiz, M., 2008. Mass balanced and dynamic simulations of trophic models of kelp ecosystems near the Mejillones Peninsula of northern Chile (SE Pacific): comparative network structure and assessment of harvest strategies. *Ecol. Modell.* 216, 31–46. doi:10.1016/j.ecolmodel.2008.04.006
- Palubitzki von, T., 2013. Die Gemeinschaftsstruktur und Biomasse von *Sargassum muticum* im Sylter Wattenmeer.
- Patrício, J., Ulanowicz, R., Pardal, M. a., Marques, J.C., 2004. Ascendency as an ecological indicator: a case study of estuarine pulse eutrophication. *Estuar. Coast. Shelf Sci.* 60, 23–35. doi:10.1016/j.ecss.2003.11.017
- Pauly, D., 1978. A preliminary compilation of fish length growth parameters. *Berichte des Instituts für Meereskd. Christ. Kiel* 1–200.
- Pedersen, M.F., Stæhr, P.A., Wernberg, T., Thomsen, M.S., 2005. Biomass dynamics of exotic *Sargassum muticum* and native *Halidrys siliquosa* in Limfjorden, Denmark—implications of species replacements on turnover rates. *Aquat. Bot.* 83, 31–47. doi:10.1016/j.aquabot.2005.05.004
- Pockberger, M., Kellnreitner, F., Ahnelt, H., Asmus, R., Asmus, H., 2014. An abundant small sized fish as keystone species? The effect of *Pomatoschistus microps* on food webs and its trophic role in two intertidal benthic communities: a modeling approach. *J. Sea Res.* 86, 86–96. doi:10.1016/j.seares.2013.11.008
- Polte, P., Buschbaum, C., 2008. Native pipefish *Entelurus aequoreus* are promoted by the introduced seaweed *Sargassum muticum* in the northern Wadden Sea, North Sea. *Aquat. Biol.* 3, 11–18. doi:10.3354/ab00071
- Polte, P., Schanz, A., Asmus, H., 2005. The contribution of seagrass beds (*Zostera noltii*) to the function of tidal flats as a juvenile habitat for dominant, mobile epibenthos in the Wadden Sea. *Mar. Biol.* 147, 813–822. doi:10.1007/s00227-005-1583-z
- Reichert, K., Buchholz, F., 2006. Changes in the macrozoobenthos of the intertidal zone at Helgoland (German Bight, North Sea): a survey of 1984 repeated in 2002. *Helgol. Mar. Res.* 60, 213–223. doi:10.1007/s10152-006-0037-4
- Reise, K., 1998. Pacific oysters invade mussel beds in the European Wadden Sea. *Senckenbergiana maritima* 28, 167–175. doi:10.1007/BF03043147

-
- Reise, K., 2002. Sediment mediated species interactions in coastal waters. *J. Sea Res.* 48, 127–141. doi:10.1016/S1385-1101(02)00150-8
- Reise, K., 2005. Coast of change: habitat loss and transformations in the Wadden Sea. *Helgol. Mar. Res.* 59, 9–21. doi:10.1007/s10152-004-0202-6
- Reise, K., Herre, E., Sturm, M., 1994. Biomass and abundance of macrofauna in intertidal sediments of Königshafen in the northern Wadden Sea. *Helgoländer Meeresuntersuchungen* 48, 201–215. doi:10.1007/BF02367036
- Rueness, J., 1989. *Sargassum muticum* and other introduced Japanese macroalgae: Biological pollution of European coasts. *Mar. Pollut. Bull.* 20, 173–176. doi:10.1016/0025-326X(89)90488-8
- Rutledge, R.W., Basore, B.L., Mulholland, R.J., 1976. Ecological Stability: an information theory viewpoint. *J. Theor. Biol.* 57, 355–371.
- Salvaterra, T., Green, D.S., Crowe, T.P., O’Gorman, E.J., 2013. Impacts of the invasive alga *Sargassum muticum* on ecosystem functioning and food web structure. *Biol. Invasions* 15, 2563–2576. doi:10.1007/s10530-013-0473-4
- Sanchez, I., Fernandez, C., 2005. Impact of the invasive seaweed *Sargassum muticum* (Phaeophyta) on an intertidal macroalgal Assemblage 1. *J. Phycol.* 41, 923–930. doi:10.1111/j.1529-8817.2005.00120.x
- Schories, D., Albrecht, A., Lotze, H., 1997. Historical changes and inventory of macroalgae from Königshafen bay in the northern Wadden Sea. *Helgol. Mar. Res.* 341, 321–341.
- Schückel, U., Schückel, S., Beck, M., Liebezeit, G., 2010. New range expansion of *Caprella mutica* Schurin, 1935 (Malacostraca: Caprellidae) to the German coast, North Sea. *Aquat. Invasions* 5, S85–S89. doi:10.3391/ai.2010.5.S1.018
- Shucksmith, R., Cook, E.J., Hughes, D.J., Burrows, M.T., 2009. Competition between the non-native amphipod *Caprella mutica* and two native species of caprellids *Pseudoprotella phasma* and *Caprella linearis*. *J. Mar. Biol. Assoc. United Kingdom* 89, 1125–1132. doi:10.1017/S0025315409000435
- Simon, J., 2007. Age, growth, and condition of European eel (*Anguilla anguilla*) from six lakes in the River Havel system (Germany). *ICES J. Mar. Sci.* 7, 1414–1422.
- Smaal, A., Stralen, van M., Craeymeersch, J., 2005. Does the introduction of the pacific oyster *Crassostrea gigas* lead to species shifts in the Wadden Sea?, in: Dame, R., Olenin, S. (Eds.), the cooperative roles of suspension-feeders in ecosystems. *NATO Science Series IV. Earth&Environmental Sciences Vol. 47*. Kluwer Academic Publishers, Dordrecht, pp. 277–289.
- Sparre, P., Venema, C.S., 1998. Introduction to tropical fish stock assessment. Part 1. Manual. *FAO Fish. Tech. Pap. Rev.* 2, 1–407.

-
- Stæhr, P.A., Pedersen, M.F., Thomsen, M.S., Wernberg, T., Krause-Jensen, D., 2000. Invasion of *Sargassum muticum* in Limfjorden (Denmark) and its possible impact on the indigenous macroalgal community. *Mar. Ecol. Prog. Ser.* 207, 79–88.
- Strong, J., Dring, M., Maggs, C., 2006. Colonisation and modification of soft substratum habitats by the invasive macroalga *Sargassum muticum*. *Mar. Ecol. Prog. Ser.* 321, 87–97. doi:10.3354/meps321087
- Sturaro, N., Caut, S., Gobert, S., Bouquegneau, J.-M., Lepoint, G., 2010. Trophic diversity of idoteids (Crustacea, Isopoda) inhabiting the *Posidonia oceanica* litter. *Mar. Biol.* 157, 237–247. doi:10.1007/s00227-009-1311-1
- Thurston, R.V., Gehrke, P., 1993. Respiratory oxygen requirements of fishes: description of OXYREF, a data file based on test results reported in the published literature, in: Russo, R.C. & T.R.V. (Ed.), *Fish Physiology, Toxicology, and Water Quality Management. Proceedings of an International Symposium.* US Environmental Protection Agency EPA/600/R-93/157., Sacramento, California, USA, pp. 95–108.
- Tweedley, J., Jackson, E., Attrill, M., 2008. *Zostera marina* seagrass beds enhance the attachment of the invasive alga *Sargassum muticum* in soft sediments. *Mar. Ecol. Prog. Ser.* 354, 305–309. doi:10.3354/meps07242
- Ulanowicz, R., 1986. Theoretical ecology: ecosystem ascendancy, in: 1987 Yearbook of Science and Technology. McGraw-Hill, New York, pp. 481–483.
- Ulanowicz, R., Norden, J., 1990. Symmetrical overhead in flow networks. *Int. J. Syst. Sci.* 21, 429–437. doi:10.1080/00207729008910372
- Ulanowicz, R.E., 1997. Ecology, the ascendent perspective.
- Ulanowicz, R.E., 2000. Ascendancy: a measure for system performance, in: Jorgensen, S., Müller, F. (Eds.), *Handbook of Ecosystem Theories and Management.* Lewis Publishers, Boca Raton, pp. 305–315.
- Ulanowicz, R.E., 2003. Some steps toward a central theory of ecosystem dynamics. *Comput. Biol. Chem.* 27, 523–530. doi:10.1016/S1476-9271(03)00050-1
- Ulanowicz, R.E., 2004. Quantitative methods for ecological network analysis. *Comput. Biol. Chem.* 28, 321–39. doi:10.1016/j.compbiolchem.2004.09.001
- Ulanowicz, R.E., Kay, J.J., 1991. A package for the analysis of ecosystem flow networks. *Environ. Softw.* 6, 131–142.
- Ulanowicz, R.E., Mason, D.M., Krause, A., Jaeger, A., Hunter, T., Clites, A., 2005. Netwrk 4.2c, a network analysis package.
- Ulanowicz, R.E., Puccia, C., 1990. Mixed trophic impacts in ecosystems. *Coenoses* 5, 7–16.

-
- Vassilenko, S., 1991. Eco-physiological characteristic of some common caprellid species in the Possjet Bay (the Japan Sea). *Hydrobiologia* 223, 181–187. doi:10.1007/BF00047640
- Viejo, R.M., 1999. Mobile epifauna inhabiting the invasive *Sargassum muticum* and two local seaweeds in northern Spain. *Aquat. Bot.* 64, 131–149. doi:10.1016/S0304-3770(99)00011-X
- Wernberg, T., Thomsen, M., Stæhr, P., Pedersen, M., 2000. Comparative phenology of *Sargassum muticum* and *Halidrys siliquosa* (Phaeophyceae: Fucales) in Limfjorden, Denmark. *Bot. Mar.* 43, 31–39.
- Wiêcaszek, B., 1998. On the morphometry and growth rate in the viviparous eel-pout, *Zoarces viviparus* (Zoaridae) from waters of different salinity. *Ital. J. Zool.* 211–214.
- Willis, K.J., Cook, E.J., Lozano-Fernandez, M., Takeuchi, I., 2004. First record of the alien caprellid amphipod, *Caprella mutica*, for the UK. *J. Mar. Biol. Assoc. UK* 84, 1027–1028. doi:10.1017/S0025315404010355h
- Winberg, G.G., 1956. Rate of metabolism and food requirements of fishes. *J Fish Res Board Can Transl Ser* 202.
- Wulff, F., Field, J.G., Mann, K.H., 1989. Coastal and estuarine studies, in: Wulff, F., Field, J.G., Mann, K.H. (Eds.), *Coastal and Estuarine Studies* 32. Springer-Verlag, Heidelberg.
- Yendo, K., 1907. The Fucaceae of Japan. *J. Coll. Sci. Imp. Univ. Tokyo, Japan* 21, 1–174.

SYNTHESIS & CONCLUSION

The aim of the present thesis was to clarify impacts of fish on the organisation, structure and food web of the Wadden Sea on different spatial scales:

- At the species scale the impact of a dominant small-sized fish species on the food web of sandy tidal flats was investigated by employing network analyses.
- At the habitat scale the energy flow of new habitats formed by invasive bioengineer species is shown and revealed to what extent these habitats influence the fish community.
- On the regional scale the influence of large scale and regional driving forces were assessed on the abundance and trophic interactions of fish species in coastal boreal waters.
- These aims were exemplified for the fish fauna of the Sylt-Rømø bight, a well investigated part of the Wadden Sea.

Species scale:

The presence or absence particularly of abundant species might influence the transport of energy in Wadden Sea habitats (Chapter II).

Especially small seized fish, feeding on zooplankton, meiofauna and small macrofauna are important links in the food web as they facilitate energy flow from lower to higher levels up to top predators (e.g. Behrends, 1985; Cury, 2000; Coll and Libralato, 2012). The presence or absence of species at the base of the food web, connected to other components of a food web via direct and indirect trophic interactions, will have a distinct impact on the flow of energy within the whole food web. Diversity, structure, organisation and stability of the

community or ecosystem will be affected (Jackson et al., 2001; McPeck, 1998; Myers and Worm, 2003; Worm et al., 2006). The species *Pomatoschistus microps* was chosen, as this species is an abundant and characteristic species for the whole Wadden Sea area (Jager et al., 2009; Vorberg and Breckling, 1999). According to these food webs *P. microps* was found to be a keystone species. The concept of keystones is discussed in Chapter II p. 110 (see also p. 18). *Pomatoschistus microps* is omnivore, which results in a multitude of trophic interactions in the food web (e.g. Zander and Hartwig, 1982; Norte-Campos and Temming, 1994; Kellnreitner et al., 2012) particularly it is representing prey items for top predators (e.g. Behrends, 1985; Kubetzki and Garthe, 2003). Thus this example shows the importance of small-seized omnivore species for the energy flow in food webs. At first time the role of this species in the food web was analysed quantitatively by employing the routines of EwE and NETWRK (Chapter II). Both programs include analog routines, but have distinctive advantages and disadvantages in calculating and analysing ecological networks (Christian et al., 2005; Heymans and Baird, 2000). Employing routines of both programs to estimate the impact of *P. microps* provides a reliable basis for further interpretation of results. In Chapter II direct and indirect impacts of *P. microps* on the food web were calculated.

Direct impacts reveal predator-prey relationships. While predators impact the investigated species negatively, prey species are regarded as positive impacts. Direct impacts further hint to the importance of the investigated species for bottom down and bottom up effects inside a food web. For *P. microps* in the Sylt-Rømø bight direct impacts and accordingly direct bottom up and bottom down effects through predation were found to be small compared to indirect effects.

Negative indirect impacts indicate inter- and intraspecific competition for food resources (Christensen et al., 2008). Positive indirect impacts reveal beneficial effects for prey items of

the investigated species (Ulanowicz and Puccia, 1990), e.g. in the Sylt-Rømø bight sediment POC is an important food resource for prey items of *P. microps*, thus a positive impact for *P. microps* could be observed. The investigation of direct and indirect relationships reveals hidden links inside food webs.

Results give also clear indication of a similar importance of this species composition in other habitats in the Wadden Sea as the species composition and trophic interactions are similar (e.g. Beukema, 1976; Doornbos and Twisk, 1987; Mees et al., 1993; Hostens and Hamerlynck, 1994; Hampel and Cattrijsse, 2004). Beside *P. microps* other species such as *Pomatoschistus minutus*, *Crangon crangon* and even *Carcinus maenas*, might represent important trophic links, as they are omnivores, present in the food web all year round and occur additionally in certain seasons in high abundances (Ropes, 1968; Beukema, 1976, 1992; Norte-Campos and Temming, 1994).

Habitat scale:

At the habitat scale I discuss my results with respect to the mutual interactions between fish and habitat, focusing on one of the new habitats created by the oyster *Crassostrea gigas* and the macroalgae *Sargassum muticum*. In this thesis I gave the first quantitative description of the food web of a community formed by invasive species. Comparisons between the characteristic sandy habitats and structured habitats newly created by invaded species showed significant differences in species composition and abundance of fish (Chapter III). Employing statistical analyses these differences are based firstly on the abundance of certain species, such as *C. harengus*, *S. rostellatus* and *A. tobianus*, which were caught in much higher number on sandy habitats compared to algal habitats. Secondly, although trawl samplings covered larger areas

than samplings in *S. muticum* forests, three species (*A. anguilla*, *P. microps*, *S. spinachia*) were exclusively found in *S. muticum*.

The impacts of the invasive species *C. mutica* and *S. muticum* (Chapter IV) indicate mainly positive effects on fish species, but ambiguous effects for small invertebrates, such as amphipods. For fish *C. mutica* depicts an easy accessible prey item, due to high abundances and sedentary life style, further *S. muticum* forests increase habitat complexity and may act as substitute for lost subtidal plant canopies (Buschbaum and Gutow, 2005; Polte and Buschbaum, 2008; Willis et al., 2004). Increased habitat complexity was also found to be beneficial for small invertebrates (e.g. Markert et al., 2009; Viejo, 1999), but *C. mutica* was described as a strong competitor for small native invertebrates, foraging in the same trophic level (Shucksmith et al., 2009).

The results of the Ecological Network Analysis provide several indices characterising the status of the system. These indices give values to describe certain ecosystem conditions, allow the evaluation of the ecosystem status (e.g. Heymans and Baird, 2000) and may be used to compare the characteristics of different ecosystems (Christian et al., 2005).

Indices provide useful and reliable tools to characterise ecosystems (Baird and Ulanowicz, 1989; Baird et al., 1998; Christian and Ulanowicz, 2002; Monaco and Ulanowicz, 1997; Ulanowicz, 2004). The definition and determination of biological indicators, such as certain native and invasive species or concentrations of nutrients, as well as indices derived from ecological analyses and modelling is an important current discussion to develop tools for the estimation of ecosystems evolutions (Borja et al., 2013, 2009).

Comparing the results of ENA (Chapter IV) to other systems dominated by macrophytes, similar patterns could be observed: high effective trophic efficiency on lower trophic levels, a steep decline of efficiency in higher trophic levels, finally a strong dependency on detritus

import (Jia et al., 2012; Ortiz, 2008). Comparing indices calculated for *Sargassum* forest to seagrass beds in the Wadden Sea, algal forest can be described as more organised but less stable systems. Baird et al. (2012) studied the effects of invasive abundant species (*A. modestus*, *C. gigas*) on system organisation in the Wadden Sea and concluded that species might control energy flow due to high abundance, but may not put the system in danger, if abundance declines the stability of energy flows and the organisation of the system can be influenced, which may be the case for *C. mutica* and *S. muticum*.

Rodriguez (2006) described several criteria how invasive species influence directly native organisms in a beneficial way by providing new habitat and suitable prey resources. Indirect effects are a decreased predation pressure, as invasive species may depict more attractive prey resources, and therefore reduced competition between native species. The author further states, that successful introduction of species will in general cause a decrease of abundance and production of native species occupying a similar ecological niche. Invasive species may not only impact native species, and accordingly influence system's organisation, moreover the expansion of other invasive species may be facilitated (Buschbaum and Gutow, 2005; Rodriguez, 2006). Due to changes in the abundance of native species and the invasion of bioengineer species, new habitat – species interactions in the Wadden Sea can be observed (Polte and Buschbaum, 2008; Lang and Buschbaum, 2010; Baird et al., 2012).

An example is the loss of subtidal seagrass meadows of *Zostera marina* in the Wadden Sea. Since the decrease of *Z. marina*, the majority of remaining dense seagrass canopies in the Wadden Sea are formed by *Zostera noltii* and mainly found in intertidal areas (Polte and Asmus, 2006). This caused changes in the species composition of the communities (Beusekom et al., 2012; Reise and Beusekom, 2008). The algae *S. muticum* might become a substitute for lost plant canopies in subtidal areas (Polte and Buschbaum, 2008). On the

other hand algae may also be a threat by overgrowing to remaining seagrass beds (Den Hartog, 1994).

Den Hartog (1997) investigated the possibility of *S. muticum* as a threat to *Z. noltii* and concluded that the algae impacts seagrass meadows by overgrowing suitable habitats, inhibiting the establishment and expansion of permanent seagrass meadows. In the Sylt-Rømø bight and in the Wadden Sea seagrass meadows act as sediment traps and nutrient sinks, providing storage for resources (e.g. POC), reducing the export of energy and providing the sustainability of the ecosystem (Asmus and Asmus, 1998, 2000; Baird et al., 2007). Currently, in intertidal areas *Z. noltii* recovers and is spreading in the German Wadden Sea, while subtidal *Z. marina* is still extremely rare (Dolch et al., 2013). *Sargassum* forests have different features than seagrass beds. This new habitat will be beneficial for certain species (Chapter IV), but in total it might not be an equivalent substitute for subtidal seagrass beds because of less resilience against disturbances.

Regional scale:

Results of the investigations reveal the occurrence of 47 fish species within the Sylt-Rømø bight. Most of these fish species are affected by large scale oscillations and local climate conditions, habitat and water quality and numerous trophic interactions (Chapter I). Therefore they are impacted by a multitude of environmental parameters and characteristics, as found in the present study, but also in other studies (e.g. Pörtner et al., 2001; Brander, 2007; Pörtner and Knust, 2007; Kellnreitner et al., 2012). Fish react on altered environmental conditions with changing migration patterns and recruitment success (Attrill and Power, 2002; Brandt and Kronbak, 2010; Gibson, 1997; Henderson and Seaby, 2005; Henderson, 2007; Philippart et al., 1996; Veer et al., 2011). Changes of fish migration,

residence time in a certain area, trophic interactions and success of recruitment have been observed and may indicate changing abiotic and biotic processes up to the point of transformations of ecosystems (Dulvy et al., 2008, 2004; Whitfield and Elliott, 2002).

Since fish use a multitude of habitats and occupy different trophic positions during their life cycle, the identification of critical or endangered habitats might be difficult (Roessig et al., 2004; Rose, 2000). Kennedy (1990), Carlton (1996) and Lotze et al. (2006) describe coastal areas as endangered and heavily impacted. Due to anthropogenic alterations and climatic shifts conditions become unfavorable for many native species. For the Wadden Sea, alterations of coastal, intertidal and subtidal habitats caused the change to a heavily impacted system depending on energy imports of adjacent areas (Asmus, 1994; Reise, 2005; Scholten et al., 1990). Several fish monitoring and surveys are conducted in different regions of the North Sea and Wadden Sea to observe ongoing changes in fish communities (Tulp et al. 2008, Jager et al., 2009,).

In the study, described in Chapter I, the fish community in the Wadden Sea shows changing species compositions and partly declining abundances for priority species due to changing water temperatures. Priority species are defined as endangered species being important food sources for higher trophic levels and sensitive towards changing environmental conditions (Bolle et al., 2009; Jager et al., 2009; Kellnreitner, 2012; Tulp et al., 2008). Further investigations state a loss of nursery and foraging areas for juvenile fish and the absence of larger or adult specimens (Veer et al., 2011; Weijerman et al., 2005; Wolff, 2013). The present analysis of fish is related to habitat and climate (Chapter I), and is investigating changes in the fish community representative for the northern Wadden Sea. Lusitanian species dominate in terms of species numbers, but certain boreal-benthopelagic species feeding mainly on zooplankton (e.g. *Clupea harengus*, *Ammodytes tobianus*) were found to

be most abundant (Chapter I, Table 1). Kellnreitner et al. (2012) conclude that the Sylt-Rømø bight differs from other areas due to a higher importance of zooplankton as a food resource, however according to species composition the bight represents a typical Wadden Sea habitat.

Correlations with temperature indicate positive trends for boreal-benthopelagic and lusitanian groups, but negative for fish in the boreal-arctic and boreal-demersal groups (Chapter I, Fig. 7). Tulp et al. (2008) stated an increase of planktivore and benthivore species, noting that lusitanian species mostly forage on benthic resources. In addition to feeding types and geographical origin, longevity, age-groups, occurrence of species throughout the year and thermal tolerance should be considered (Elliott and Dewailly, 1995; Tulp et al., 2008). Present results give a hint of future developments regarding fish in the Sylt-Rømø bight and the Wadden Sea (Chapter I). Monthly sampling throughout whole years proved to be necessary to consider dynamic temporal fluctuations of most of the fish species in this environment. In this way a high resolution of abundance patterns was achieved and resident and temporary present species of different size classes could be considered (Chapter I). Moreover fish species were grouped into boreal, boreal-arctic and Atlantic/lusitanian according to the thermal tolerance.

The impact of large scale climate oscillations such as the NAO on fish is not completely clarified in the Wadden Sea (Philippart et al., 1996; Tulp et al., 2008). Impacts of NAO on fish are found in other areas of the North Sea (e.g. Sims et al., 2004, Henderson and Seaby, 2005; Nyitrai et al., 2013). Different life-stages of fish species are affected by NAO (Sims et al., 2004; Svendsen et al., 1991), resulting in somehow unclear effects. Nevertheless, calculations, presented in Chapter I, give significant relationships regarding NAO and fish. Correlating peak abundances of demersal species were observed during periods of lower

NAO values, while peak abundances of pelagic species occurred during times of higher values. Interestingly impacts could not be based on geographic origin or thermal tolerance, mainly fish in the same habitat (benthopelagic, demersal, pelagic) were impacted. Regarding statistical calculations highest correlations between peak abundance and impact of NAO were found for the biogeographic-habitat group Atlantic pelagic species (Chapter I, Table 4). In this group mainly adult individuals of fast swimming species (*Salmo* spp., *S. scombrus*) were caught, which might be able to migrate when conditions change.

The consideration of several perspectives will improve the understanding of ecosystem - fish interactions and identify possible developments in the Wadden Sea. As well as climate conditions influence species composition and abundance, internal characteristics such as material cycling, are influenced by the biota (Fig. 1).

The study of fish helped to understand the internal processes and patterns forming the basis of organisation and energy flow in ecosystems (see Chapter II, IV; further Carpenter et al., 1985; Powell et al., 1991; Flecker, 1992; Montgomery et al., 1996; Gelwick et al., 1997; Larkin and Slaney, 1997; Holmlund and Hammer, 1999). If environmental conditions are altered, fish might react with changing migration patterns, and recruitment success may be influenced (Attrill and Power, 2002; Brandt and Kronbak, 2010; Gibson, 1997; Henderson and Seaby, 2005; Henderson, 2007; Philippart et al., 1996; Veer et al., 2011). Changes of fish migration, residence time, trophic interactions and success of recruitment have been observed and may indicate changing abiotic and biotic processes up to the point of transformations of ecosystems (Dulvy et al., 2008, 2004; Whitfield and Elliott, 2002).

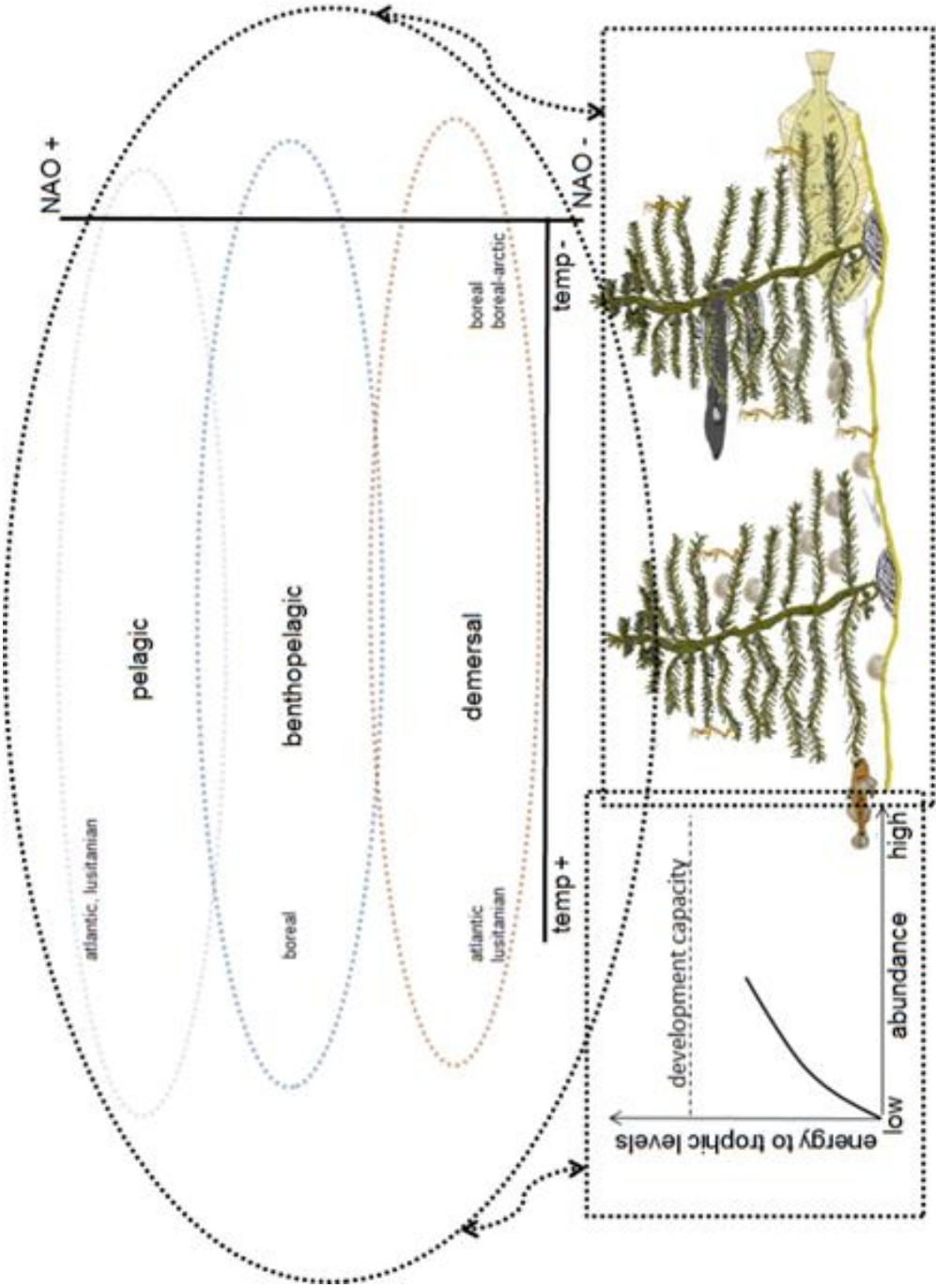

Fig. 1. Schematic overview of the interplay of positive (+) and negative (-) external (North Atlantic Oscillation, NAO), and internal (e.g. temperature, temp) factors on biogeographic fish groups (Atlantic, boreal, boreal-arctic, lusitanian) in different domains (benthopelagic, demersal, pelagic). The impact of abundant species increasing energy flow (*Pomatoschistus microps*) and changing species composition and abundance (e.g. *Pleuronectes flesus*, *Anguilla anguilla*, various amphipods) through invasive species (*Sargassum muticum*, *Caprella mutica*) is illustrated.

Conclusion

The present investigation elucidates ecosystem species interactions, considering large scale climate oscillations (NAO) and local characteristics, such as habitat structure and trophic interactions. Results indicate significant impacts of NAO and the importance of shallow coastal habitats for Wadden Sea fish species. The relevance of characteristic Wadden Sea fish species concerning the structure, organisation and energy flow is revealed. The food web of a new community formed by *Sargassum muticum* and *Caprella mutica* is at first time described and the impact of these species on native species is assessed. Successful invasive species change the characteristics of native communities and transform the food web substantially. The here presented interdependencies might contribute to the understanding of future developments at the ecosystem level of the Wadden Sea.

References Synthesis & Conclusion

- Asmus, H., 1994. Benthic grazers and suspension feeders: which one assumes the energetic dominance in Königsshafen? *Helgol. Mar. Res.* 48, 217–231.
- Asmus, H., Asmus, R., 1998. The role of macrobenthic communities for sediment-water material exchange in the Sylt-Rømø tidal basin. *Senckenbergiana maritima* 29, 111–119.
- Attrill, M.J., Power, M., 2002. Climatic influence on a marine fish assemblage. *Nature* 417, 275–278. doi:10.1038/417275a
- Baird, D., Asmus, H., Asmus, R., 2007. Trophic dynamics of eight intertidal communities of the Sylt-Rømø bight ecosystem, northern Wadden Sea. *Mar. Ecol. Prog. Ser.* 351, 25–41. doi:10.3354/meps07137
- Baird, D., Asmus, H., Asmus, R., 2012. Effect of invasive species on the structure and function of the Sylt-Rømø bight ecosystem, northern Wadden Sea, over three time periods. *Mar. Ecol. Prog. Ser.* 462, 143–161. doi:10.3354/meps09837
- Baird, D., Luckovich, J., Christian, R., 1998. Assessment of spatial and temporal variability in ecosystem attributes of the St Marks National wildlife refuge, Apalachee Bay, Florida.
- Baird, D., Ulanowicz, R.E., 1989. The seasonal dynamics of the Chesapeake Bay ecosystem. *Ecol. Monogr.* 59, 329–364.
- Behrends, G., 1985. Zur Nahrungswahl von Seehunden (*Phoca vitulina* L.) im Wattenmeer Schleswig-Holsteins. *Zeitschrift für Jagdwissenschaften* 31, 3–14.
- Beukema, J.J., 1976. Biomass and species richness of the macro-benthic animals living on the tidal flats of the Dutch Wadden Sea. *J. Sea Res.* 261, 236–261.
- Beukema, J.J., 1992. Dynamics of juvenile shrimp *Crangon crangon* in a tidal-flat nursery of the Wadden Sea after mild and cold winters. *Mar. Ecol. Prog. Ser.* 83, 157–165.
- Beusekom, van J.E.E., Buschbaum, C., Reise, K., 2012. Wadden Sea tidal basins and the mediating role of the North Sea in ecological processes: scaling up of management? *Ocean Coast. Manag.* 68, 69–78. doi:10.1016/j.ocecoaman.2012.05.002
- Bolle, L.J., Neudecker, T., Vorberg, R., Damm, U., Diederichs, B., Jager, Z., Scholle, J., Daenhardt, A., Lüerßen, G., Marencic, H., 2009. Trends in Wadden Sea Fish Fauna Part I: Trilateral Cooperation.
- Borja, A., Elliott, M., Andersen, J.H., Cardoso, A.C., Carstensen, J., Ferreira, J.G., Heiskanen, A.-S., Marques, J.C., Neto, J.M., Teixeira, H., Uusitalo, L., Uyarra, M.C., Zampoukas, N., 2013. Good environmental status of marine ecosystems: what is it and how do we know when we have attained it? *Mar. Pollut. Bull.* 76, 16–27. doi:10.1016/j.marpolbul.2013.08.042

-
- Borja, A., Ranasinghe, A., Weisberg, S., 2009. Assessing ecological integrity in marine waters, using multiple indices and ecosystem components: challenges for the future. *Mar. Pollut. Bull.* 59, 1–4. doi:10.1016/j.marpolbul.2008.11.006
- Brander, K.M., 2007. Global fish production and climate change. *Proc. Natl. Acad. Sci. U. S. A.* 104, 44–46.
- Brandt, U.S., Kronbak, L.G., 2010. On the stability of fishery agreements under exogenous change: an example of agreements under climate change. *Fish. Res.* 101, 11–19. doi:10.1016/j.fishres.2009.08.012
- Buschbaum, C., Gutow, L., 2005. Mass occurrence of an introduced crustacean (*Caprella cf. mutica*) in the south-eastern North Sea. *Helgol. Mar. Res.* 59, 252–253. doi:10.1007/s10152-005-0225-7
- Carlton, J.T., 1996. Pattern, process, and prediction in marine invasion ecology. *Biol. Conserv.* 78, 97–106.
- Carpenter, S.R., Kitchell, J.F., Hodgson, J.R., 1985. Cascading trophic interactions and lake productivity. *Bioscience* 35, 634–639.
- Christensen, V., Walters, C.J., Pauly, D., Forrest, R., 2008. *Ecopath with Ecosim version 6 User Guide*. Lensfest Ocean Futures Project 2008.
- Christian, R., Ulanowicz, R., 2002. Network ecology, in: El-Shaarawi, A., Piegorisch, W. (Eds.), *Encyclopedia of environmetrics*. John Wiley and Sons, Chinchester, pp. 1393–1399.
- Christian, R.R., Baird, D., Luczkovich, J., C, J.J., Scharler, U.M., Ulanowicz, R.E., 2005. Role of network analysis in comparative ecosystem ecology of estuaries, in: Belgrano, A., Scharler, U.M., Dunne, J., Ulanowicz, R.E. (Eds.), *Aquatic Food Webs and Ecosystem Approach*. Oxford University Press, Oxford, pp. 25–40.
- Coll, M., Libralato, S., 2012. Contributions of food web modelling to the ecosystem approach to marine resource management in the Mediterranean Sea. *Fish Fish.* 13, 60–88. doi:10.1111/j.1467-2979.2011.00420.x
- Cury, P., 2000. Small pelagics in upwelling systems: patterns of interaction and structural changes in “wasp-waist” ecosystems. *ICES J. Mar. Sci.* 57, 603–618. doi:10.1006/jmsc.2000.0712
- Den Hartog, C., 1994. Suffocation of a littoral *Zostera* bed by *Enteromorpha radiata*. *Aquat. Bot.* 47, 21–28. doi:10.1016/0304-3770(94)90045-0
- Den Hartog, C., 1997. Is *Sargassum muticum* a threat to eelgrass beds? *Aquat. Bot.* 58, 37–41.
- Dolch, T., Buschbaum, C., Reise, K., 2013. Persisting intertidal seagrass beds in the northern Wadden Sea since the 1930s. *J. Sea Res.* 82, 134–141. doi:10.1016/j.seares.2012.04.007

-
- Doornbos, G., Twisk, F., 1987. Density, growth and annual food consumption of gobiid fish in the saline lake Grevelingen, the Netherlands. *J. Sea Res.* 21, 45–74.
- Dulvy, N.K., Freckleton, R.P., Polunin, N.V.C., 2004. Coral reef cascades and the indirect effects of predator removal by exploitation. *Ecol. Lett.* 7, 410–416. doi:10.1111/j.1461-0248.2004.00593.x
- Dulvy, N.K., Rogers, S.I., Jennings, S., Stelzenmüller, V., Dye, S.R., Skjoldal, H.R., 2008. Climate change and deepening of the North Sea fish assemblage: a biotic indicator of warming seas. *J. Appl. Ecol.* 45, 1029–1039. doi:10.1111/j.1365-2664.2008.01488.x
- Elliott, M., Dewailly, F., 1995. The structure and components of European estuarine fish assemblages. *Netherl. J. Aquat. Ecol.* 29, 397–417.
- Flecker, A.S., 1992. Fish trophic guilds and the structure of a tropical stream : weak direct vs. strong indirect effects. *Ecology* 73, 927–940.
- Gelwick, F., Stock, M., Matthews, W., 1997. Effects of fish, water depth, and predation risk on patch dynamics in a north-temperate river ecosystem. *OIKOS* 80, 382–398.
- Gibson, R.N., 1997. Behaviour and the distribution of flatfishes. *J. Sea Res.* 37, 241–256. doi:10.1016/S1385-1101(97)00019-1
- Hampel, H., Cattrijsse, A., 2004. Temporal variation in feeding rhythms in a tidal marsh population of the common goby *Pomatoschistus microps* (Kroyer, 1838). *Aquat. Sci.* 66, 315–326. doi:10.1007/s00027-004-0682-0
- Henderson, P.A., 2007. Discrete and continuous change in the fish community of the Bristol channel in response to climate change. *J. Mar. Biol. Assoc. UK* 87, 589–598. doi:10.1017/S0025315407052447
- Henderson, P.A., Seaby, R.M., 2005. The role of climate in determining the temporal variation in abundance, recruitment and growth of sole *Solea solea* in the Bristol channel. *J. Mar. Biol. Assoc. UK* 85, 197–204. doi:10.1017/S0025315405011069h
- Heymans, J., Baird, D., 2000. Network analysis of the northern Benguela ecosystem by means of NETWRK and ECOPATH. *Ecol. Modell.* 131, 97–119. doi:10.1016/S0304-3800(00)00275-1
- Holmlund, C.M., Hammer, M., 1999. Ecosystem services generated by fish populations. *Ecol. Econ.* 29, 253–268. doi:10.1016/S0921-8009(99)00015-4
- Hostens, K., Hamerlynck, O., 1994. The mobile epifauna of the soft bottoms in the subtidal Oosterschelde estuary: structure, function and impact of the storm-surge barrier. *Hydrobiologia* 282-283, 479–496. doi:10.1007/BF00024650

- Jackson, J.B., Kirby, M.X., Berger, W.H., Bjorndal, K.A., Botsford, L.W., Bourque, B.J., Bradbury, R.H., Cooke, R., Erlandson, J., Estes, J.A., Hughes, T.P., Kidwell, S., Lange, C.B., Lenihan, H.S., Pandolfi, J.M., Peterson, C.H., Steneck, R.S., Tegner, M.J., Warner, R.R., 2001. Historical overfishing and the recent collapse of coastal ecosystems. *Science* (80). 293, 629–37. doi:10.1126/science.1059199
- Jager, Z., Bolle, L., Dänhardt, A., Diederichs, B., Neudecker, T., Scholle, J., Vorberg, R., 2009. Thematic Report No. 14, in: Marencic, H., Vlas de, J. (Eds.), Wadden Sea Quality Status Report (QSR) 2009. Trilateral Monitoring and Assessment Group (TMAG) Common Wadden Sea Secretariat, Wilhelmshaven, pp. 1–42.
- Jia, P., Hu, M., Hu, Z., Liu, Q., Wu, Z., 2012. Modeling trophic structure and energy flows in a typical macrophyte dominated shallow lake using the mass balanced model. *Ecol. Modell.* 233, 26–30. doi:10.1016/j.ecolmodel.2012.02.026
- Kellnreitner, F., 2012. The trophic structure of a Wadden Sea fish community and its feeding interactions with alien species. Christian-Albrechts-University, Kiel.
- Kellnreitner, F., Pockberger, M., Asmus, H., 2012. Seasonal variation of assemblage and feeding guild structure of fish species in a boreal tidal basin. *Estuar. Coast. Shelf Sci.* 108, 97–108. doi:10.1016/j.ecss.2011.02.020
- Kennedy, V.S., 1990. Anticipated effects of climate change on estuarine and coastal fisheries. *Fisheries* 15, 16–24.
- Kubetzki, U., Garthe, S., 2003. Distribution, diet and habitat selection by four sympatrically breeding gull species in the south-eastern North Sea. *Mar. Biol.* 143, 199–207. doi:10.1007/s00227-003-1036-5
- Lang, A.C., Buschbaum, C., 2010. Facilitative effects of introduced Pacific oysters on native macroalgae are limited by a secondary invader, the seaweed *Sargassum muticum*. *J. Sea Res.* 63, 119–128. doi:10.1016/j.seares.2009.11.002
- Larkin, G.A., Slaney, P.A., 1997. Implications of trends in marine-derived nutrient influx to south coastal British Columbia salmonid production. *Fish. Res.* 22, 16–24.
- Lotze, H.K., Lenihan, H.S., Bourque, B.J., Bradbury, R.H., Cooke, R.G., Kay, M.C., Kidwell, S.M., Kirby, M.X., Peterson, C.H., Jackson, J.B.C., 2006. Depletion, degradation, and recovery potential of estuaries and coastal seas. *Science* (80-). 312, 1806–1809. doi:10.1126/science.1128035
- Markert, A., Wehrmann, A., Kröncke, I., 2009. Recently established *Crassostrea*-reefs versus native *Mytilus*-beds: differences in ecosystem engineering affects the macrofaunal communities (Wadden Sea of Lower Saxony, southern German Bight). *Biol. Invasions* 12, 15–32. doi:10.1007/s10530-009-9425-4
- McPeck, M.A., 1998. The consequences of changing the top predator in a food web: a comparative experimental. *Ecol. Monogr.* 68, 1–23.

-
- Mees, J.A.N., Dewlicke, A.N.N., Hamerlynck, O., 1993. Seasonal composition and spatial distribution of hyperbenthic communities along estuarine gradients in the Westerschelde. *Netherlands J. Aquat. Ecol.* 27, 359–376.
- Monaco, M.E., Ulanowicz, R.E., 1997. Comparative ecosystem trophic structure of three US . mid-Atlantic estuaries. *Mar. Ecol. Prog. Ser.* 161, 239–254.
- Montgomery, D.R., Buffington, J.M., Peterson, N.P., Schuett-Hames, D., Quinn, T.P., 1996. Stream-bed scour, egg burial depths, and the influence of salmonid spawning on bed surface mobility and embryo survival. *Can. J. Fish. Aquat. Sci.* 53, 1061–1070. doi:10.1139/f96-028
- Myers, R.A, Worm, B., 2003. Rapid worldwide depletion of predatory fish communities. *Nature* 423, 280–3. doi:10.1038/nature01610
- Norte-Campos del, A.G.C., Temming, A., 1994. Daily activity, feeding and rations in gobies and brown shrimp in the northern Wadden Sea. *Mar. Ecol. Prog. Ser.* 115, 41–53. doi:10.3354/meps115041
- Nyitrai, D., Martinho, F., Dolbeth, M., Rito, J., Pardal, M.A., 2013. Effects of local and large-scale climate patterns on estuarine resident fishes: The example of *Pomatoschistus microps* and *Pomatoschistus minutus*. *Estuar. Coast. Shelf Sci.* 135, 260–268. doi:10.1016/j.ecss.2013.10.030
- Ortiz, M., 2008. Mass balanced and dynamic simulations of trophic models of kelp ecosystems near the Mejillones Peninsula of northern Chile (SE Pacific): comparative network structure and assessment of harvest strategies. *Ecol. Modell.* 216, 31–46. doi:10.1016/j.ecolmodel.2008.04.006
- Philippart, C.J., Lindeboom, H., Meer, van der J., Veer, van der H., Witte, J., 1996. Long-term fluctuations in fish recruit abundance in the western Wadden Sea in relation to variation in the marine environment. *ICES J. Mar. Sci.* 53, 1120–1129.
- Polte, P., Asmus, H., 2006. Intertidal seagrass beds (*Zostera noltii*) as spawning grounds for transient fishes in the Wadden Sea. *Mar. Ecol. Prog. Ser.* 312, 235–243. doi:10.3354/meps312235
- Polte, P., Buschbaum, C., 2008. Native pipefish *Entelurus aequoreus* are promoted by the introduced seaweed *Sargassum muticum* in the northern Wadden Sea, North Sea. *Aquat. Biol.* 3, 11–18. doi:10.3354/ab00071
- Pörtner, H., Berdal, B., Blust, R., Brix, O., Colosimo, A., De Wachter, B., Giuliani, A., Johansen, T., Fischer, T., Knust, R., Lannig, G., Naevdal, G., Nedenes, A., Nyhammer, G., Sartoris, F.J., Serendero, I., Sirabella, P., Thorkildsen, S., Zakhartsev, M., 2001. Climate induced temperature effects on growth performance , fecundity and recruitment in marine fish : developing a hypothesis for cause and effect relationships in Atlantic cod (*Gadus morhua*) and common eelpout (*Zoarces viviparus*). *Cont. Shelf Res.* 21, 1975–1997.

-
- Pörtner, H.O., Knust, R., 2007. Climate change affects marine fishes through the oxygen limitation of thermal tolerance. *Science* (80-). 95. doi:10.1126/science.1135471
- Powell, G.V.N., Fourqurea, J.W., Ziemanb, J.C., 1991. Bird colonies cause seagrass enrichment in a subtropical estuary: observational and experimental evidence. *Estuar. Coast. Shelf Sci.* 32, 567–579.
- Reise, K., 2005. Coast of change: habitat loss and transformations in the Wadden Sea. *Helgol. Mar. Res.* 59, 9–21. doi:10.1007/s10152-004-0202-6
- Reise, K., Beusekom, van J.E.E., 2008. Interactive effects of global and regional change on a coastal ecosystem. *Helgol. Mar. Res.* 62, 85–91. doi:10.1007/s10152-007-0102-7
- Rodriguez, L.F., 2006. Can invasive species facilitate native species? Evidence of how, when, and why these impacts occur. *Biol. Invasions* 8, 927–939. doi:10.1007/s10530-005-5103-3
- Roessig, J.M., Woodley, C.M., Cech, J.J., Hansen, L.J., 2004. Effects of global climate change on marine and estuarine fishes and fisheries. *Rev. Fish Biol. Fish.* 251–275.
- Ropes, J.W., 1968. The feeding habits of the green crab, *Carcinus maenas* (L.). *Fish. Bull.* 67, 183–203.
- Rose, K.A., 2000. Why are quantitative relationships between environmental quality and fish populations so elusive ? *Ecol. Appl.* 10, 367–385.
- Scholten, H., Kleppner, O., Nienhuis, P., Knoester, M., 1990. Oosterschelde estuary (S.W. Netherlands): a self-sustaining ecosystem? *Dev. Hydrobiol.* 55, 201–215.
- Shucksmith, R., Cook, E.J., Hughes, D.J., Burrows, M.T., 2009. Competition between the non-native amphipod *Caprella mutica* and two native species of caprellids *Pseudoprotella phasma* and *Caprella linearis*. *J. Mar. Biol. Assoc. United Kingdom* 89, 1125–1132. doi:10.1017/S0025315409000435
- Sims, D.W., Mouth, V.J.W., Genner, M.J., Southward, A.J., Hawkins, S.J., 2004. Low-temperature-driven early spawning migration of a temperate marine fish. *J. Anim. Ecol.* 73, 333–341.
- Svendsen, E., Aglen, A., Iversen, S., Skagen, D., Smestad, O., 1991. Influence of climate on recruitment and migration of fish stocks in the North Sea. *ICES, Pelagic Fish Comm.* H:12, 32.
- Tulp, I., Bolle, L.J., Rijnsdorp, A.D., 2008. Signals from the shallows: in search of common patterns in long-term trends in Dutch estuarine and coastal fish. *J. Sea Res.* 60, 54–73. doi:10.1016/j.seares.2008.04.004
- Ulanowicz, R.E., 2004. Quantitative methods for ecological network analysis. *Comput. Biol. Chem.* 28, 321–39. doi:10.1016/j.compbiolchem.2004.09.001

-
- Ulanowicz, R.E., Puccia, C., 1990. Mixed trophic impacts in ecosystems. *Coenoses* 5, 7–16.
- Veer, van der H., Koot, J., Aarts, G., Dekker, R., Diderich, W., Freitas, V., Witte, J., 2011. Long-term trends in juvenile flatfish indicate a dramatic reduction in nursery function of the Balgzand intertidal, Dutch Wadden Sea. *Mar. Ecol. Prog. Ser.* 434, 143–154. doi:10.3354/meps09209
- Viejo, R.M., 1999. Mobile epifauna inhabiting the invasive *Sargassum muticum* and two local seaweeds in northern Spain. *Aquat. Bot.* 64, 131–149. doi:10.1016/S0304-3770(99)00011-X
- Vorberg, R., Breckling, P., 1999. Atlas der Fische im Schleswig-Holsteinischen Wattenmeer. Schriftenr. des Natl. Schleswig-Holsteinisches Wattenmeer 10, 178.
- Weijerman, M., Lindeboom, H., Zuur, A.F., 2005. Regime shifts in marine ecosystems of the North Sea and Wadden Sea. *Mar. Ecol. Prog. Ser.* 298, 21–39.
- Whitfield, K., Elliott, M., 2002. Fishes as indicators of environmental and ecological changes within estuaries: a review of progress and some suggestions for the future. *J. Fish Biol.* 61, 229–250. doi:10.1006/jfbi.2002.2079
- Willis, K.J., Cook, E.J., Lozano-Fernandez, M., Takeuchi, I., 2004. First record of the alien caprellid amphipod, *Caprella mutica*, for the UK. *J. Mar. Biol. Assoc. UK* 84, 1027–1028. doi:10.1017/S0025315404010355h
- Wolff, W.J., 2013. Ecology of the Wadden Sea: Research in the past and challenges for the future. *J. Sea Res.* 82, 3–9. doi:10.1016/j.seares.2013.03.006
- Worm, B., Barbier, E.B., Beaumont, N., Duffy, J.E., Folke, C., Halpern, B.S., Jackson, J.B.C., Lotze, H.K., Micheli, F., Palumbi, S.R., Sala, E., Selkoe, K. A, Stachowicz, J.J., Watson, R., 2006. Impacts of biodiversity loss on ocean ecosystem services. *Science* 314, 787–90. doi:10.1126/science.1132294
- Zander, D., Hartwig, E., 1982. On the biology of small-seized fish from North and Baltic Sea areas. IV. Investigations on an eulittoral mud flat at Sylt island. *Helgol. Mar. Res.* 35, 47–63.

APPENDIX

The following supplement accompanies Chapter II

AN ABUNDANT SMALL SIZED FISH AS KEYSTONE SPECIES? THE EFFECT OF POMATOSCHISTUS MICROPS ON FOOD WEBS AND ITS TROPHIC ROLE IN TWO INTERTIDAL BENTHIC COMMUNITIES: A MODELING APPROACH

Supplement 1. The consumption rates of *Pomatoschistus microps* in the two investigated subsystems. Consumption values for one month are given in g C m^{-2} , - indicates no *P. microps* caught on sampling date.

	<i>Arenicola</i> flat	sparse <i>Z. noltii</i> bed
August 2006	0.04	0.07
September 2006	0.05	-
October 2006	0.09	0.03
December 2006	0.01	0.05
June 2008	0.01	-
August 2008	0.13	0.02
September 2008	0.10	0.01
October 2008	0.01	<0.01
December 2008	<0.01	<0.01
January 2009	<0.01	<0.01
March 2009	<0.01	-
April 2009	<0.01	-
May 2009	0.01	-
June 2009	<0.01	-
July 2009	0.01	0.01
August 2009	0.03	0.03

Supplement 2. The carbon flow in model 1, model 2 and model 3 in *Arenicola* flat and sparse *Z. noltii* bed, which is used for network calculation, is given in 6 sections. These are: names of the compartments, standing stock (mg C m^{-2}), imports ($\text{mg C m}^{-2} \text{d}^{-1}$) followed by exports ($\text{mg C m}^{-2} \text{d}^{-1}$) and respiration ($\text{mg C m}^{-2} \text{d}^{-1}$) of all living compartments and finally the energy flow ($\text{mg C m}^{-2} \text{d}^{-1}$) from prey compartment to consumer compartment. This data is in the format recommended by the SCOR and can be used in NETWRK 4.2. Supplementary data to this chapter can be found online at <http://dx.doi.org/10.1016/j.seares.2013.11.008>.

The following supplement accompanies Chapter IV

INTERNAL PROCESSES OF A HABITAT FORMING SPECIES: WHAT IS HIDDEN BEHIND DENSE FORESTS OF *SARGASSUM MUTICUM*?

Supplement 3. The carbon flow in *Sargassum muticum* forest, which is used for network calculation, is given in 3 sections. These are: names of the compartments, standing stock (mg C m^{-2}), imports ($\text{mg C m}^{-2} \text{d}^{-1}$) followed by exports ($\text{mg C m}^{-2} \text{d}^{-1}$) and respiration ($\text{mg C m}^{-2} \text{d}^{-1}$) of all living compartments and finally the energy flow ($\text{mg C m}^{-2} \text{d}^{-1}$) from prey compartment to consumer compartment. This data is in the format recommended by the SCOR and can be used in NETWRK 4.2.

Sargassum muticum; Sylt-Romo bight; Wadden Sea; 2010
33 30

Phytoplankton	12 1.9664000E+00	13 3.9024110E+01
Mikrophytobenthos	13 1.4879607E+03	14 3.4375920E+01
Sargassum muticum	14 1.7560733E+03	15 5.4299400E+00
freeliving bacteria	15 2.0578750E+02	16 4.5299800E+00
sediment bacteria	16 3.4335986E+02	17 4.6845500E+00
Zooplankton	17 3.5507578E+02	18 1.7703000E+00
Meiobenthos	18 1.0362447E+02	19 2.3522000E+00
Crassostrea gigas	19 1.3765330E+02	20 6.4130000E-02
Cerastoderma sp.	20 1.6973893E+00	21 1.4806281E+02
Mya sp.	21 3.9191181E+03	22 6.0220000E-02
Lanice sp.	22 9.4878205E+00	23 6.2899000E-01
Nereidae	23 2.8147122E+01	24 6.5968300E-06
Apherusa spp.	24 6.4930960E-01	25 1.2604500E-06
Corophium spp.	25 1.3293964E-01	26 4.0521952E-02
Gammarus spp.	26 3.9657234E+00	27 2.0009283E+00
Caprella linearis	27 4.0018567E+00	28 8.5446172E-02
Caprella mutica	28 2.2709866E+00	29 4.8188370E-02
Jassa spp.	29 3.0117731E+00	30 9.6787163E-01
Idotea spp.	30 4.0735900E+01	-1 0.0
Palemon sp.	31 0.0000000E+00	1 6 4.6000000E+00
Crangon crangon	32 0.0000000E+00	1 8 1.5850000E+02
Carcinus maenas	33 2.0166165E+02	1 10 1.4303000E+02
Pomatoschistus microps	-1 0.0	1 11 2.0085883E-02
Spinachia spinachia	1 3.7643000E+02	1 12 9.4458870E-03
Syngnathus rostellatus	2 1.2872600E+03	1 32 1.7040000E+01
Pleuronectes platessa	3 1.5300000E+03	2 7 3.2447431E+02
Plathichthys flesus	4 7.8260000E+01	2 8 1.0416000E+02
Zoarces viviparus	31 1.5220000E+02	2 9 1.4028000E+02
Myoxocephalus scorpius	32 1.5334000E+02	2 12 9.4458870E-03
Anguilla anguilla	-1 0.0	2 14 3.7531660E+01
DOC	3 1.0335544E+03	3 13 5.8179568E+01
suspended POC	-1 0.0	3 15 7.7839410E+00
sediment POC	1 5.3230000E+01	3 16 1.2636600E-01
1 1.0930000E+03	2 6.8800000E+02	3 17 1.3067800E-01
2 1.3000000E+02	3 4.2840000E+02	3 19 1.8250620E+00
3 5.1165000E+05	4 7.0500000E+01	4 8 1.8050000E+01
4 9.8000000E+00	5 1.9260000E+02	4 9 1.4028000E+02
5 6.2500000E+02	6 4.0000000E-01	4 10 1.6400000E+00
6 1.1200000E+01	7 5.7091049E+02	4 11 2.3630450E-04
7 6.8454495E+03	8 3.3502455E+02	5 12 4.7153000E-02
8 9.4500000E+04	9 2.6381780E+01	5 14 6.2478860E+00
9 1.6890826E+04	10 7.8290750E+01	5 26 6.6500000E-04
10 1.5397289E+04	11 1.3120000E-02	5 27 4.4306300E-01
11 1.3109600E+00	12 2.3100000E-02	5 33 1.8216123E+02

6 16 2.8549400E-01	13 29 3.1642929E-02	18 15 1.5455000E-02
6 17 2.9523500E-01	13 30 8.6389138E-02	18 16 1.3963000E-02
6 23 5.0098370E+00	14 13 9.5115600E-01	18 17 1.4440000E-02
6 24 3.7670000E-03	14 15 2.6121100E-01	18 20 9.1300000E-04
6 25 1.3570000E-03	14 16 2.3630200E-01	18 21 2.1072950E+00
6 26 1.4105200E-01	14 17 2.4383000E-01	18 22 2.1703750E-03
6 28 6.1121400E-01	14 20 1.5465000E-02	18 23 1.0733939E-02
7 19 9.1253100E-01	14 21 3.5707375E+01	18 25 4.4197900E-05
7 20 2.3741000E-02	14 22 3.6776000E-02	18 26 2.9252000E-04
7 21 5.4814960E+01	14 23 5.7002000E-02	18 28 2.8453110E-03
7 22 4.7452000E-02	14 24 9.1638830E-03	18 30 1.7826820E-03
7 23 2.3171500E-01	14 25 1.1614000E-03	19 20 1.2123880E-03
7 25 5.1522690E-03	14 26 9.6926500E-04	19 21 2.7992950E+00
7 26 1.9960190E-03	14 28 1.3286035E-02	19 22 2.8830900E-03
7 28 1.0067055E-02	14 30 5.9069070E-03	20 33 3.7270000E-02
7 33 3.5467935E+02	15 13 1.1146200E-01	21 26 1.3306790E-03
8 33 1.1784452E+02	15 15 3.0610000E-02	21 27 1.4768757E-01
9 23 1.7977885E-02	15 16 2.7693000E-02	21 30 2.9194003E-01
9 26 4.4910420E-03	15 17 2.8638000E-02	21 33 8.5612638E+01
9 27 9.5996919E-01	15 20 1.8120000E-03	22 26 2.6610000E-03
9 28 3.5953800E-04	15 21 4.1844110E+00	22 28 2.8760000E-03
9 30 1.8474330E-01	15 22 4.3096670E-03	22 30 7.6634259E-01
9 33 3.9326463E+02	15 23 4.7305937E-02	23 26 6.6534000E-04
10 23 5.9926280E-03	15 24 4.9622610E-03	23 28 1.4381510E-03
10 26 1.4970140E-03	15 25 3.4283700E-04	23 29 2.0524676E-02
10 27 2.8799076E+00	15 26 1.0023370E-03	23 30 2.1895502E-01
10 28 1.0786130E-03	15 28 1.1644100E-02	23 33 5.4192905E+00
10 30 6.8423450E-03	15 30 6.1084580E-03	24 33 1.4125484E-01
10 33 8.7099422E+01	16 13 1.8599700E-01	25 33 2.5331915E-02
11 20 2.3291482E-02	16 15 5.1079000E-02	26 33 1.4858049E-01
11 21 5.3777921E+01	16 16 4.6212000E-02	27 33 4.0018567E+00
11 22 5.4548511E-02	16 17 4.7789000E-02	28 33 7.3573789E-01
11 23 1.6628194E-01	16 20 3.0240000E-03	29 33 4.4172672E-02
11 26 6.3297170E-03	16 21 6.9825090E+00	30 33 8.5675358E-01
11 27 6.1469961E-01	16 22 7.1915240E-03	31 4 1.5220000E+02
11 28 2.3088149E-02	16 23 5.3692181E-02	32 8 1.7215509E+02
11 30 8.6792983E-02	16 24 7.2696682E-02	32 9 1.4028000E+02
12 20 1.5880556E-02	16 25 4.2221960E-03	32 10 2.3626792E+01
12 21 3.6666764E+01	16 26 2.6116230E-03	32 11 3.3082630E-03
12 22 3.7192166E-02	16 28 1.4353895E-02	32 12 9.4458870E-03
12 23 1.1337405E-01	16 29 3.2161670E-03	32 16 6.0374950E+00
12 26 6.3117350E-03	16 30 9.7346440E-03	32 17 6.2435030E+00
12 27 8.6217608E-01	17 13 1.9234300E-01	32 18 2.7477940E+00
12 28 1.5741920E-02	17 15 5.2822000E-02	32 19 9.1253085E-01
12 30 5.9177034E-02	17 16 4.7789000E-02	32 23 1.9975428E-01
13 13 8.0106200E-01	17 17 4.9419000E-02	32 24 1.8834860E-03
13 15 2.1999200E-01	17 20 3.1270000E-03	32 26 1.9960190E-03
13 16 1.9902800E-01	17 21 7.2207620E+00	32 27 2.9537514E-01
13 17 2.0581900E-01	17 22 7.4369090E-03	32 28 1.0067055E-02
13 20 1.3025000E-02	17 23 2.2530033E-01	32 30 1.8246252E-02
13 21 3.0072665E+01	17 24 1.9044311E-02	33 5 3.8150000E+02
13 22 3.0972865E-02	17 25 6.8740890E-03	33 7 6.5716315E+02
13 23 1.6527758E-01	17 26 5.2453250E-03	33 12 9.2922960E-03
13 24 2.9743843E-02	17 28 6.0341966E-02	33 14 6.2329360E+00
13 25 6.1790510E-03	17 29 3.6977270E-02	-1 0.0
13 26 4.5164020E-03	17 30 8.1663817E-02	
13 28 4.2781915E-02	18 13 5.6133000E-02	

DANKSAGUNG

Diese Arbeit wäre nicht möglich gewesen, ohne die Unterstützung, die konstruktive Kritik, das Vertrauen und die Hilfe folgender Personen.

Der erste Dank gebührt meinem Betreuer Dr. Harald Asmus und seiner Frau Dr. Ragnhild Asmus, ihr habt mir die Möglichkeit gegeben an der Wattenmeerstation Sylt zu arbeiten, meine Ansätze und Ideen unterstützt, mich aber auch in konstruktiven Diskussionen vor so manchem Irrtum bewahrt. Besonders bedanke ich mich für die Geduld während meiner langen Schreibzeit und das ihr nicht das Vertrauen verloren habt.

Ich danke Dr. Matthias Strasser und dem dem Team des Erlebniszentrums Naturgewalten Sylt für die Unterstützung während meiner Zeit auf Sylt, diese hat meine Doktorarbeit mit ermöglicht.

Ohne Dr. Harald Ahnelt wäre ich nicht an die Wattenmeerstation Sylt gekommen, danke für deinen Einsatz und Zuspruch.

Wissenschaft ist Teamwork und deshalb möchte ich mich, neben Dr. Harald Asmus und Dr. Ragnhild Asmus, bei den weiteren Mitarbeitern meiner Arbeitsgruppe Birgit Hussel, Petra Kadel, Dr. Florian Kellnreitner, Tatyana Romanova und Margit Ludwig Schweikert bedanken.

Birgit deine Kenntnisse der Inselgeographie und deine Kontakte haben das Probennehmen, vor allem das Fischen mit der Strandwade, um ein vielfaches erleichtert. Danke für deine Hilfe, Geduld und Ruhe beim Erklären und Helfen vom Abwiegen auch noch so kleiner Organismen.

Petra dein Durchblick, nicht nur beim Planen von wissenschaftlichen Arbeiten, sondern auch deine Kenntnisse von bürokratischen Abläufen und deren Bewältigung hat mich nicht nur einmal vor zeitlichen Verzögerungen bewahrt. Ich danke für deine Hilfsbereitschaft und deine positive offene Art, mit der du mir bei Problemen geholfen hast.

Florian wir haben nicht nur ein Büro geteilt, sondern auch zusammen gewohnt, was für uns beide nicht immer leicht war, da der Alltag es einfach mit sich bringt, dass man manchmal nicht so gut miteinander kann. Trotzdem hast du mir immer bedingungslos geholfen und warst für konstruktive Diskussionen da. Ich bedanke mich für fast 9 Jahre guter Zusammenarbeit.

Tatyana danke dass du mir geholfen hast mich bei den Langzeitdaten zurecht zu finden und immer bereit warst beim Fischmonitoring mit zu helfen.

Margit deine Begeisterung, auch bei Kälte und ungünstigen Bedingungen, am Schiff und im Watt waren ansteckend und haben so manches unangenehme Monitoring erträglich und leichter durchführbar gemacht.

Um im Watt vernünftig arbeiten zu können braucht es Material und manchmal recht absonderliche Hilfsmittel um Proben zu nehmen.

Elisabeth Herre danke, dass du immer darauf geachtet hast, dass genug Material zur Verfügung steht und mir geholfen hast Kabelbinder, Seile, Netze, Moniereisen, Maßbänder, Hammer, Schraubenzieher, Schaufeln,... kurz alles was man so braucht, zu finden und deine Erfahrungen über das Arbeiten im Watt mit mir geteilt hast.

Gerda Bardt und Kristin Kessenich ich bedanke mich bei euch für die Hilfe eine Unterkunft und Wohnung in List zu finden, außerdem für die Organisation von bürokratischen Angelegenheiten.

Hanne Halliger danke für deine Hilfe bei der Organisation und Vorbereitung von Kursen und beim Beschaffen von Material.

Reimer Magens und Rene Gerrits danke für eure Geduld euch meine noch so abstrusen Ideen und Baupläne anzuhören und diese dann mit Erfahrung, Wissen über Material und Verarbeitung und Geschick zu realisieren.

Alfred Resch, Kai von Bohlen und Paul Walter euch danke ich für die Hilfe beim Arbeiten am Schiff, das Teilen eures Wissens über Wetter, Tidenströmungen, Geheimnisse der Netzreparatur und technische Details zur Fischerei und Seemannschaft.

Für die Bereitschaft mit mir über die verschiedenen Aspekte meiner Arbeit zu diskutieren und mir die Augen für andere Blickwinkel zu öffnen möchte ich mich bei Dr. Patrick Polte, Dr. Christian Buschbaum, Dr. Tobias Dolch, Dr. Maarten Boersma, Dr. Lisa Shama, Dr. Mathias Wegner, Dr. Karsten Reise, Dr. Werner Armonies, Dr. Christian Hass, Dr. Finn Mielck und Dr. Justus van Beusekom bedanken.

Danke an Dr. Dan Baird, der mir geduldig die Grundlagen der Ecological Network Analysis erklärt hat und nie die Hoffnung aufgegeben hat, dass ich diese auch eines Tages verstehen werde.

Ich bedanke mich bei meinen Praktikanten Anna Broich, Annika Feduik, Gerrit Fiedler, Tim Katzenberger, Jannes Landschoff, Niels Reinecke und Julia Werner. Danke für eure Unterstützung und helfenden Hände.

Ich komme aus Wien, bin ein Stadtmensch und habe nie am Land gelebt, deshalb waren die ersten Wochen und Monate auf Sylt, trotz guter Arbeitsbedingungen und lieber Kollegen, hart für mich. Die Zeit auf Sylt wäre nicht so schön gewesen und der Abschied nicht so schwer gefallen ohne die folgenden Menschen:

Ana, Andreas, Anna, Anne, Benoit, Bernhardt, Birger, Camille, Caro, Christian B., Christian H., Christina, Christina S., Diane, Dominik, Elias, Eric, Felix, Finn, Florian, Franziska, Jan, Hung, Jonathan, Kaibil, Karsten, Kevin, Kristina, Kristin, Lea, Lars, Lilo, Lisa, Martin, Mathias,

Michael, Niels, Niko, Nina E., Nina W., Olli, Patrick, Peter, Petra, Rene, Sabine, Sophia, Thea, Tiki, Tobi D., Tobi M, Ute.

Ich danke euch für eure Offenheit, Freundschaft und für eine gute gemeinsame Zeit, die ich vermisse.

Dass ich Wien nicht ganz vergesse, dafür haben Aurel, Bernhardt, Cristian, Pablo, Phillip und Salar gesorgt. Danke euch, dass auch wenn wir uns über mehrere Monate nicht sehen es keine Fremdheit oder Befangenheit zwischen uns gibt und ich weiß dass ihr da seid.

Das Schreiben der Doktorarbeit war manchmal von Rückschlägen, Frust und Verzweiflung geprägt, in diesen Momenten haben mich neben den zuvor genannten Menschen, besonders die Magdaleni durch ihre fröhliche Art, ihre besonnen Klugheit, ihre Liebe zur Wissenschaft und Biologie wieder motiviert und aufgerichtet. Magdaleni danke, dass du mich erstens in dieser Zeit ertragen hast und zweitens mir mit deinem Witz und deinen Ratschlägen aus verwickelten Situationen geholfen hast.

Abschließend möchte ich mich bei meiner Familie bedanken, für eure bedingungslose Unterstützung, für euer Verständnis, dass ich so lange an meiner Arbeit herumdoktere und vor allem für euer nie nachlassendes Interesse und eure Fragen, die mir helfen meine Arbeit aus neuen Perspektiven zu sehen und eingefahrene Denkmuster zu durchbrechen.

CURRICULUM VITAE**Personal:**

Name: Moritz Johannes Pockberger
Date of Birth: 05.04.1978
Place of Birth: Vienna, Austria
e-mail: moritz.pockberger@awi.de

Academic education:

Jan 2013-Apr 2013: Research Assistant: Empfehlungen zur Anwendung von Ökosystemanalysen zur Beurteilung des Nahrungsnetzes im Wattenmeer in der Meeresstrategie Rahmenrichtlinie, financed by the Nationalparkverwaltung Niedersächsisches Wattenmeer

2008-2014: PhD thesis at Alfred-Wegener Institute (AWI) Helmholtz Center for Polar and Marine Research, Wadden Sea Station Sylt, Germany (Supervisor: Dr. Harald Asmus)

Nov 2007-Mar 2008: Research assistant for the evaluation and data analyses of extraction sites for beach nourishment

Apr 2008: Research Assistant: SPICE II Project, AWI Helmholtz Center for Polar and Marine Research

2006-2007: Diploma thesis: Das Nahrungsspektrum der Sandgrundeln *Pomatoschistus minutus* und *Pomatoschistus microps* (Teleostei Gobiidae) in der Sylt-Rømø Bucht (Deutschland). University of Vienna (Supervisors: Dr. Haral Ahnelt and Dr. Harald Asmus)

2006: Summer School of the AWI
Diversity of Coastal Habitats, Sylt and Helgoland, Germany

2005: Internship: Protection of sea turtles (*Caretta caretta*) Fethiye/Turkey

1999-2007: Study of Biology, University of Vienna

1996-1999: Study of Medicine, University of Vienna (not finished)

1988-1996: Akademisches Gymnasium, Beethovenplatz 1, Vienna

1984-1988: Elementary School, Gumpendorferstr. 4, Vienna

Conference Presentations:

Pockberger, M. , Kellnreitner, F. and Asmus, H. (2011): Significance of fish for food webs in the Wadden Sea , Wadden Sea Day 2011, Wilhelmshaven – Wattenmeerhaus, 25 August 2011 - 25 August 2011

Pockberger, M., Kellnreitner, F. (2010): Fish response to change: impacts on species composition and feeding guild structure, ECSA Conference 46: The Wadden Sea: Change and Challenges in a World Heritage 03.-06.05.2010.

Kellnreitner, F., Pockberger, M., Asmus, H. (2010): Feeding guild structure of fishes in the Wadden Sea. Seasons Specialties. It is served., ECSA Conference 46: The Wadden Sea: Changes and Challenges in a World Heritage Site. Sylt, Germany. 03.-06.05.2010.

Pockberger, M., Kellnreitner, F., Ahnelt, H., Asmus, H. (2010): Comperative feeding ecology of two sympatric benthic predators, ECSA Conference 46: The Wadden Sea: Change and Challenges in a World Heritage 03-06.05.2010.

Kellnreitner F., Pockberger M. Langzeitdatensätze BFA Fisch & AWI 12.11.2008 Fischbeprobungen in der Sylt-Rømø Bucht.

Kellnreitner F., Pockberger M. 53. Kuratoriumssitzung 20. Mai 2008 Auswirkungen des Klimawandels auf die Fischfauna des Wattenmeeres.

Teaching experience

2009, 2010, 2011: Teaching assistant: Anatomy of fish course, University of Vienna (Sylt)

2009: Lecturer: Summer School on Ecology of Changing Sandy Coasts: The fish fauna of the Sylt-Rømø bight, with special emphasis on trophic relationships

2006: Lecturer: Summer School on Diversity of Coastal Habitats: Gut content analyses and Population dynamics of gobys (genus *Pomatoschistus*) in the Sylt-Rømø bight

Grants and Fundings recieved

2006: Short Research Stays Abroad program (KWA) by the Research Services and International Relations (FSIB) of the University of Vienna

Publications:

Pockberger M., Kellnreitner F., Ahnelt H., Asmus R., Asmus H., (2014) An abundant small sized fish as keystone species? The effect of *Pomatoschistus microps* on food webs and its trophic role in two intertidal benthic communities: A modeling approach. Journal of Sea Research 86: 86-96.

Kellnreitner F., Pockberger M., Asmus R., Asmus H (2013) Feeding interactions between the introduced ctenophore *Mnemiopsis leidyi* and juvenile herring *Clupea harengus* in the Wadden Sea. *Biological Invasions* 15: 871-884.

Wegner M.K., Shama L.N.S., Kellnreitner F., Pockberger M. (2012) Diversity of immune genes and associated gill microbes of European plaice *Pleuronectes platessa*. *Estuarine Coastal and Shelf Science* 108, 87-96.

Kellnreitner F., Pockberger M. Asmus H. (2012) Seasonal variation of assemblage and feeding guild structure of fish species in a boreal tidal basin. *Estuarine Coastal and Shelf Science* 108, 97-108.

EIDESSTATTLICHE ERKLÄRUNG

Hiermit versichere ich eidesstattlich, dass die vorliegende Arbeit:

Abiotic and biotic impacts on fish in the Wadden Sea. Evaluating the effect of large scale climate oscillations, local ecosystem characteristics and invasive species.

mit Hilfe meiner Betreuer, Co-Autoren und Praktikanten und nur unter Zuhilfenahme der angegebenen Hilfsmittel und Quellen erstellt habe.

Die Arbeit wurde unter Einhaltung der Regeln guter wissenschaftlicher Praxis der Deutschen Forschungsgemeinschaft verfasst.

Die Arbeit ist und wurde an keiner anderen Stelle im Rahmen eines Prüfungs- und Promotionsverfahrens vorgelegt und veröffentlicht, aber Teile dieser Arbeit wurden als Manuskript in wissenschaftlichen Zeitschriften publiziert oder werden zur Veröffentlichung eingereicht. Die Namen der entsprechenden Zeitschriften sind in der hier vorliegenden Arbeit unter Thesis Outline aufgeführt.

Ich habe bis zum heutigen Tage weder an der Christian Albrechts Universität zu Kiel noch an einer anderen Hochschule ein Promotionsverfahren endgültig nicht bestanden, noch befinde ich mich in einem entsprechenden Verfahren.

15.02.2015

Moritz Pockberger

Keep Ithaka always in your mind.

Arriving there is what you are destined for. But do not hurry the journey at all. Better if it lasts for years, so you are old by the time you reach the island, wealthy with all you have gained on the way, not expecting Ithaka to make you rich.

Constantine P. Cavafy

Source and copyright back cover:

Sunrise tidal flats; Moritz Pockberger

Sampling beach seine Florian Kellnreitner, Moritz Pockberger

Name of RV MYA I: Moritz Pockberger

Fish *Scophthalmus* spp.: Moritz Pockberger

The Wadden Sea is constantly being formed by local dynamics and large scale climatic oscillations. These abiotic characteristics define the species composition and abundance in the habitat, Wadden Sea. As the Wadden Sea represents a very dynamic and open system, species might be easily introduced which may affect native species and in the course of time the whole food web. To investigate the impact of changing abiotic characteristics and invasive species on the ecosystem Wadden Sea, this thesis was conducted. To uncover possible ongoing changes fish were chosen as the organismic subject group of the study. Fish are able to avoid unfavorable conditions by migration to other areas, acting as an indicator for ongoing changes.

