

Separability Properties and Finite-Sheeted Coverings of Graphs of Groups and 2-dimensional Orbifolds

Inaugural-Dissertation

zur Erlangung des Doktorgrades der
Mathematisch-Naturwissenschaftlichen Fakultät der
Christian-Albrechts-Universität zu Kiel

vorgelegt von

Eric Henack

Kiel, den 16.01.2018

Gutachter:

Erster Gutacher: Prof. Dr. Richard Weidmann

Zweiter Gutachter: Priv.-Doz. Dr. Amir Džambić

Tag der mündlichen Prüfung:

Dienstag, 27.03.2018

Ehrenwörtliche Erklärung zu dieser Dissertation

Sehr geehrte Damen und Herren,

hiermit erkläre ich, dass ich die vorliegende Arbeit abgesehen von der Beratung durch den Betreuer meiner Promotion unter Einhaltung der Regeln guter wissenschaftlicher Praxis der Deutschen Forschungsgemeinschaft selbstständig angefertigt habe und keine anderen als die angegebenen Hilfsmittel verwendet habe. Ich versichere außerdem, dass ich diese Dissertation nur in diesem und keinem anderen Promotionsverfahren eingereicht habe und, dass diesem Promotionsverfahren keine endgültig gescheiterten Promotionsverfahren vorausgegangen sind.

Datum

Unterschrift

Danksagung

Bedanken möchte ich mich an dieser Stelle als erstes einmal bei Richard Weidmann, für die Wahl des Ausgangsthemas und die sehr gute Betreuung. Dabei möchte ich besonders hervorheben, dass er maßgeblich Anteil daran hat bzw. hatte, dass die Arbeitsatmosphäre innerhalb unserer Arbeitsgruppe außerordentlich humorvoll, freundlich, verständnisvoll und respektvoll ist bzw. war. Sein Umgang mit seinen Studenten ist wirklich vorbildlich und das ist sicher nicht selbstverständlich. Für mich war bei diesem Vorhaben immer der Weg das Ziel. In diesem Sinne möchte ich mich für die schöne und lustige Zeit bedanken! Es hat sehr viel Spaß gemacht!

Natürlich gebührt auch den anderen Mitgliedern der Arbeitsgruppe, Amir Dzambic, David Konietzko, Simon Heil und Ederson Dutra, Dank für die bereits erwähnte gute Arbeitsatmosphäre und für den anregenden fachlichen Austausch. Dabei möchte ich mich in besonderem Maße bei Ederson bedanken, der auch für Themen, welche nicht das Unileben betrafen, ein guter Ansprechpartner ist und war.

Nicht unerwähnt möchte ich an dieser Stelle auch alte Wegbegleiter lassen: Ich danke Sissi Andreeva für die vielen Gespräche über Mathematik und auch andere Themen zu Beginn meines Hauptstudiums. Diese Gespräche haben mir sehr geholfen ein gewisses mathematisches Selbstbewusstsein zu entwickeln und waren somit wegebend für mein weiteres Mathematik Studium. Ebenso möchte ich Herrn Stellmacher und Herrn Schmidt danken, welche mit Ihren Vorlesungen mein Interesse an der reinen Mathematik entfachten.

Des Weiteren möchte ich allen Personen danken, welche mich im privaten Kreis während meines Studiums unterstützt und begleitet haben.

Besonderer Dank gebührt dabei meinen Eltern, Tino und Loreen Henack, und meinen beiden Schwestern, Desiree und Svenja Henack, dass sie mir immer ein "zu Hause" waren. Zudem danke ich meinen Eltern dafür, dass sie während meines Studiums immer für mich da waren und mich bei meinem eigenen, nicht immer geradlinig verlaufenden, Weg durch das Studium, stets unterstützt haben.

Des Weiteren möchte ich an dieser Stelle Trang Doan für die lange Zeit danken, die sie mich während meines Studiums begleitet hat. Sie hat diese Zeit und somit auch mein Wesen ebenso mit geprägt wie meine Familie und mir in vielen Lebensbereichen zur Seite gestanden.

Auch hier seien ein paar alte Wegbegleiter erwähnt: Danke für die tolle Zeit zu Beginn unseres Studiums und während unserer Schulzeit, Johannes Schmidt. Das war eine sehr lustige Zeit. Auch dir vielen Dank, Baris Yurteri, für die vielen lustigen Stunden, in welchen wir beide auch mal unmotivierter waren etwas sinnvolles zu tun.

Danke an Freunde, die es schon waren oder es während des Studiums geworden sind: Jan Bielke, Stefan Dreger, Thieß Steinke. Und auch an die "Überreste" meiner Fußballerzeit: Lasse Kleemann und Markus Schuster! Dafür, dass ihr mich so nehmt wie ich bin und immer gute Freunde wart und seid.

Zu guter Letzt möchte ich mich bei meiner besseren Hälfte, Amanda Apivontragoon, bedanken! Wir beide haben in den letzten knapp zwei Jahren schon so viele schwierigen Situationen gemeistert. Das hat dich zu einem Teil meines Lebens gemacht, den ich nicht mehr missen möchte! Danke, dass du immer bei mir bist, meine Liebe!

Zusammenfassung

Eine Gruppe G ist untergruppenkonjugationsseparabel (subgroup conjugacy separable, SCS), falls für je zwei endlich erzeugte, nicht konjugierte Untergruppen H_1 und H_2 von G ein endlicher Quotient E von G existiert, s.d. die Bilder von H_1 und H_2 in E nicht konjugiert sind. Wir werden in dieser Arbeit einen Beweis dafür liefern, dass endlich erzeugte virtuell freie Gruppen SCS sind. Dieser benutzt in erster Linie Überlagerungstheorie von Graphen von Gruppen, welche in dieser Arbeit auch ausführlich eingeführt und ausgebreitet wird. Als eine direkte Konsequenz der so gewonnenen Formel für den Index einer von einer Überlagerung von Graphen von Gruppen repräsentierten Untergruppe erhielten wir eine Formel für den Rang einer freien Untergruppe von endlichem Index in einer endlich erzeugten virtuell freien Gruppe. Dafür nutzten wir die Tatsache aus, dass jede endlich erzeugte virtuell freie Gruppe als Fundamentalgruppe eines endlichen Graphen von endlichen Gruppen aufgefasst werden kann. Des Weiteren werden wir im Sinne der erarbeiteten Überlagerungstheorie von Graphen von Gruppen eine sinnvolle Definition der Decktransformationsgruppe einer Überlagerung eines Graphen von Gruppen geben und einen Zusammenhang zwischen dieser Gruppe und dem Normalisator der repräsentierten Untergruppe herstellen. Anschließend weisen wir mit Hilfe der besagten Überlagerungstheorie von Graphen von Gruppen nach, dass Fundamentalgruppen einiger spezieller "Tower" über einer endlich erzeugten virtuell freien Gruppe untergruppenseparabel sind (subgroup separable). Dabei heißt eine Gruppe untergruppenseparabel, falls für jede Untergruppe U von G und jedes Element $g \in G \setminus U$ eine Untergruppe H von endlichem Index in G existiert, welche U als Untergruppe hat und das Element g nicht enthält. In den letzten Kapiteln werden wir dann einen Beweis dafür liefern, dass Fuchsche Gruppen SCS sind. Dieser benutzt vorrangig Überlagerungstheorie 2-dimensionaler Orbifolds. Ferner werden wir mit Hilfe dieses Beweises nachweisen, dass die Fundamentalgruppe einer total-orientierten Seifert-Mannigfaltigkeit SCS ist.

Abstract

A group G is called subgroup conjugacy separable (SCS) if for any two f.g. non-conjugate subgroups H_1 and H_2 of G , there exists a finite quotient E of G such that the images of H_1 and H_2 remain non-conjugate in E . In this thesis we will prove that, that any finitely generated virtually free group is SCS. This proof uses essentially covering theory of graphs of groups. Note that the introduction and the elaboration of this covering theory will be done as well in this thesis. As a direct consequence of the established formula for counting the index of a finite index subgroup of the fundamental group of a graph of groups, we receive a formula for counting the rank of a free finite index subgroup of a virtually free group in terms of the index of the corresponding subgroup and the finite orders of the vertex groups of the original finite graph of finite groups. For doing this we make use of the well-known fact that any f.g. virtually free group splits as a finite graph of finite groups. Furthermore in the context of covering theory of graphs of groups, we will give a reasonable definition for the group of Decktransformations associated to a cover of a graph of groups and we will establish a connection between this group and the normalizer of the represented subgroup. Later on the covering theory of graphs of groups enables us to prove the subgroup separability for some special kinds of towers over a finitely generated virtually-free group. Note that a group G is called subgroup separable if for any subgroup U of G and any element $g \in G \setminus U$ there exists a finite index subgroup H of G containing U satisfying $g \notin H$. Afterwards we are going to show that Fuchsian Groups are SCS. This proof uses essentially covering theory of 2-dimensional orbifolds. Last but not least we will use this statement to show that the fundamental group of any totally orientable Seifert fibered space is SCS.

Contents

1	Introduction	8
2	Preliminaries	15
2.1	Profinite topology	15
2.2	Profinite groups	16
2.3	Classical residual properties	19
3	Graphs of groups	22
3.1	Graphs of groups and their fundamental groups	22
3.2	Bass-Serre theory	29
3.3	Folded morphisms and covers of graphs of groups	36
3.3.1	Morphisms of graphs of groups	36
3.3.2	Folded morphisms of graphs of groups	38
3.3.3	Covers of graphs of groups	40
3.3.4	Graphs of groups covers and finite index subgroups	41
3.4	Auxiliary modifications and Decktransformations of graph of group morphisms	46
3.4.1	Auxiliary Modifications of morphisms of graphs of groups	46
3.4.2	The group of Decktransformations associated to a cover of graphs of groups	49
3.5	Structure of a covering of graphs of groups	55
3.5.1	Double Cosets	55
3.5.2	Characterising a covering by local properties	57
3.5.3	Covers of finite graph of finite groups	68
4	Towers of (k, C)-acylindrical stars of groups and the Subgroup Separability	72
4.1	(k, C) -acylindrical graphs of groups	72
4.2	Stars of groups with certain vertex groups	76
4.3	Towers of (k, C) -acylindrical stars of groups with certain "midpoint"-vertex groups	89
4.4	Towers of iterated virtual extensions of centralizers	90
5	Virtually free groups are SCS	93
5.1	Con-Separability	93
5.2	Chain Condition	94
5.3	Fully conjugacy separable groups	97
5.4	A proof that virtually free groups are SCS	100
6	Fuchsian groups are SCS	104
6.1	Virtually Polycyclic Groups	105
6.2	Subgroups of Fuchsian groups are almost geometric	107
6.3	Coverings of 2-dimensional orbifolds	110
6.4	Proof of Theorem 6.2	123
7	Totally Orientable Seifert-Fibered-Space	128

1 Introduction

In this chapter we review the results in this thesis, which mainly involve the following three separability properties of groups. The first one is the well-known subgroup separability:

Definition 2.18. *A group G is said to be **subgroup separable or LERF** (locally extended residually finite) if for every finitely generated subgroup $H \leq G$ and $g \in G \setminus H$ there exists a subgroup of finite index $K_g \leq G$ such that $H \leq K_g$ and $g \notin K_g$.*

While the second one is the so called conjugacy separability:

Definition 2.16. *A group G is **conjugacy separable** if whenever x and y are non-conjugate elements of G , there exists some finite quotient E of G in which the images of x and y are non-conjugate.*

The last one is the relatively new subgroup conjugacy separability, which was introduced 2010 in [2]:

Definition 2.20. *A group G is called **subgroup conjugacy separable** if for any two finitely generated non-conjugate subgroups $H_1, H_2 \leq G$ there exists a homomorphism ϕ from G to a finite group E such that $\phi(H_1)$ is not conjugate to $\phi(H_2)$ in E .*

In [2] the authors, namely O. Bogopolski and F. Grunewald, gave a review for which groups the *subgroup separability* was established:

- polycyclic groups (A.I. Mal'cev [24])
- free groups (M. Hall [17])
- surface groups (P. Scott [36])
- limit groups (H. Wilton [45])
- free products of LERF groups (R.G. Burns [7] and N.S. Romanovskii [35])
- free products of two free groups amalgamated along a cyclic group (A.M. Brunner, R.G. Burns and D. Solitar [6]; see also a generalization of M. Tretkoff [42])
- free products of a LERF group G and a free group F amalgamated along a maximal cyclic subgroup in F (R. Gitik [14]) (Note, that the free product of two LERF groups amalgamated along a cyclic subgroup is not necessarily a LERF group (see [34] and [15]))

If G splits as a finite graph of free groups with cyclic edge groups, then G is LERF if and only if G does not contain a non-trivial element a , such that a^n is conjugate to a^m for some $n \notin \{+m, -m\}$ (D. Wise [46]). In [27], V. Metaftsis and E. Raptis proved that a right-angled Artin group G with associated graph Γ is subgroup separable if and only if Γ does not contain a subgraph homeomorphic to either a square or a path of length three. P. Scott in [36] showed, that LERF is inherited by subgroups and finite extensions, in particular it is invariant under commensurability. In contrast, the conjugacy separability is

not invariant under commensurability: in [26], A. Martino and A. Minasyan constructed a finitely presented CS-group, which has an index 2 subgroup without the CS property. An example of a finitely generated (but not finitely presented) non-CS-group G , containing a CS-subgroup of index 2, was constructed by A. Gorjaga in [16].

The *subgroup conjugacy separability* was established for:

- Polycyclic groups (D. Segal [38])
- Surface groups (O.Bogopolski and K.U. Bux [3])
- Finitely generated virtually free groups (S.C. Chagas and P.A. Zalesskii [9])
- Limit groups (S.C. Chagas and P.A. Zalesskii [8])
- Any torsion-free hyperbolic and hereditarily-cs group which admits local retractions (O.Bogopolski and K.U. Bux [4])

Definition 5.2. *A group G is called subgroup into conjugacy separable if for any two f.g. subgroups H_1 and H_2 satisfying that H_2 is not conjugate into H_1 there exists a finite quotient of G such that the image of H_2 is not conjugate into the image of H_1 .*

In [12] the author showed that the free product of $G = A * B$ of two groups A and B is subgroup into conjugacy separable, if both, A and B are subgroup separable and subgroup into conjugacy separable. It follows that such G is SCS, if G does not admit expanding inner automorphism, i.e. there exists no automorphism $\alpha \in \text{Inn}(G)$ such that $H < H^\alpha$ is a strict inclusion for some f.g. subgroup $H \leq G$. This is true since by Corollary 5.15 this property implies the fact that if two f.g. subgroups of $H_1, H_2 \leq G$ are not conjugate in G either H_1 is not conjugate into H_2 or H_2 is not conjugate into H_1 .

Definition 3.1. *A graph of groups \mathbb{A} is a tuple*

$$(A, \{A_v | v \in VA\}, \{A_e | e \in EA\}, \{\alpha_e | e \in EA\}, \{\omega_e | e \in EA\})$$

consisting of a connected graph A and groups A_x for any $x \in VA \cup EA$. These groups are called vertex groups and edge groups, respectively. In addition, the maps $\alpha : A_e \rightarrow A_{\alpha(e)}$ and $\omega_e : A_e \rightarrow A_{\omega(e)} = A_{\alpha^{-1}(e)}$ are ment to be monomorphisms with $\omega_e = \alpha_{e^{-1}}$. These maps are called boundary monomorphisms.

To any graph of groups \mathbb{A} and some chosen base point $v_0 \in \widetilde{VA}$ one can associate the fundamental group $\pi_1(\mathbb{A}, v_0)$ and the universal covering tree $(\widetilde{\mathbb{A}}, v_0)$. The simplicial tree $(\widetilde{\mathbb{A}}, v_0)$ is a so called $\pi_1(\mathbb{A}, v_0)$ -tree, i.e. $\pi_1(\mathbb{A}, v_0)$ acts in a natural way on $(\widetilde{\mathbb{A}}, v_0)$ by automorphisms and without inversion (see chapter 3.1).

Definition 3.27. *A morphisms between a G -tree T and a H -tree Y is a pair (φ, f) , s.t. $\varphi : G \rightarrow H$ is a homomorphism of groups and $f : T \rightarrow Y$ is a graph morphism with the property that $\varphi(g)f(x) = f(gx)$ f.a. $g \in G$ and $x \in ET \cup VT$.*

The analogon of this definition in the language of graphs of groups can be expressed as follows:

Definition 3.28. *A morphism between two graphs of groups*

$$\mathbb{A} := (A, \{A_v | v \in VA\}, \{A_e | e \in EA\}, \{\alpha_e | e \in EA\}, \{\omega_e | e \in EA\})$$

and

$$\mathbb{B} := (B, \{B_w | w \in VB\}, \{B_l | l \in EB\}, \{\alpha_l | l \in EB\}, \{\omega_l | l \in EB\})$$

is a tuple

$$\mathfrak{f} = (f, \{f_v | v \in VA\}, \{f_e | e \in EA\}, \{g_e^\alpha | e \in EA\}, \{g_e^\omega | e \in EA\})$$

satisfying the following properties:

1. $f : A \rightarrow B$ is a graph morphism.
2. $f_e : A_e \rightarrow B_{f(e)}$ is a homomorphism of groups f.a. $e \in EA$.
3. $f_v : A_v \rightarrow B_{f(v)}$ is a homomorphism of groups f.a. $v \in EA$.
4. $g_e^\alpha \in B_{f(\alpha(e))}$ and $g_e^\omega \in B_{f(\omega(e))}$, with $g_e^\alpha = (g_e^{\omega^{-1}})^{-1}$, s.t.

$$f_{\alpha(e)} \circ \alpha_e(c) = g_e^\alpha \cdot (\alpha_{f(e)} \circ f_e(c)) \cdot (g_e^\alpha)^{-1}$$

for all $e \in EA$ and $c \in A_e$.

Any morphism of graphs of groups $\mathfrak{f} : \mathbb{A} \rightarrow \mathbb{B}$ induces an homomorphism of groups $\varphi_{\mathfrak{f}} : \pi_1(\mathbb{A}, v_0) \rightarrow \pi_1(\mathbb{B}, f(v_0))$ and a morphism of trees $f_{\mathfrak{f}} : (\widetilde{\mathbb{A}}, v_0) \rightarrow (\widetilde{\mathbb{B}}, f(v_0))$. We call \mathfrak{f} folded if the homomorphism f_v is injective for any $v \in VA$ and if the map on tree-level $f_{\mathfrak{f}}$ is locally injective. Furthermore we call \mathfrak{f} a **cover of graphs of groups** if \mathfrak{f} is folded and $f_{\mathfrak{f}}$ is an isomorphism of trees. In chapter 3.4 we will define an equivalence relation on the set of morphisms between two graphs of groups \mathbb{A} and \mathbb{B} , i.e. we will call two morphisms $\mathfrak{f}, \mathfrak{f}' : \mathbb{A} \rightarrow \mathbb{B}$ equivalent if they differ by an auxiliary modification (see 3.45). This will lead us to an appropriate definition of the group of Decktransformation of a cover $\mathfrak{f} : \mathbb{A} \rightarrow \mathbb{B}$ of graphs of groups, if we denote the equivalence class of some morphisms $\mathfrak{f} : \mathbb{A} \rightarrow \mathbb{B}$ by $[\mathfrak{f}]_{\equiv}$:

Definition 3.51. *Let $\mathfrak{f} : \mathbb{A} \rightarrow \mathbb{B}$ be a cover. Then we call the elements*

$$\text{Deck}(\mathfrak{f}) = \{[\mathfrak{h}]_{\equiv} | \mathfrak{h} \text{ is a graph of group automorphism of } \mathbb{A} \text{ s.t. } [\mathfrak{f} \circ \mathfrak{h}]_{\equiv} = [\mathfrak{f}]_{\equiv}\}$$

Decktransformations of \mathfrak{f} .

Suppose that in this context K is the kernel of the action of $G := \pi_1(\mathbb{B}, f(u_0))$ on $(\mathbb{B}, f(v_0))$, $N_G(U)$ is the normalizer and $Z_G(U)$ is the centralizer of the subgroup $U := \varphi_f(\pi_1(\mathbb{A}, v_0))$ in $G := \pi_1(\mathbb{B}, f(u_0))$ represented by the cover $f : \mathbb{A} \rightarrow \mathbb{B}$. Then we will show the following:

Theorem 3.59. *There exists an epimorphism $\chi : N_G(U) \rightarrow \text{Deck}(f)$ satisfying $\ker(\chi) = Z \cdot U$ if $Z := Z_G(U) \cap K$.*

Moreover we will discuss covering theory of graphs of groups detailed in 3.5 to analyze the structure of a covering of graphs of groups, i.e. we will characterize a cover by local properties. So we will turn from global, i.e. the fact that the map f_f on tree level is an isomorphism, to local properties involving double coset decompositions of vertex groups. As a direct consequence we will give a short proof for the following statement:

Theorem 3.89. *Let \mathbb{B} be a finite graph of finite groups. Then for any $n \in \mathbb{N}$ there exists a free group F of finite index in $G = \pi_1(\mathbb{B}, u_0)$ such that $|G : F| = n \cdot \text{lcm}(B_u)_{u \in VB}$.*

which obviously shows the one direction of the well-known fact:

Theorem 3.90. *A f.g. group G is virtually free if and only if G splits as a finite graph of finite groups.*

Later on we will make use of the fact that any f.g. virtually free group is subgroup separable to prove the following:

Corollary 3.94. *Any f.g. subgroup of a finite graph of finite groups is almost geometric.*

Which means that any finite graph of groups \mathbb{A} representing some f.g. subgroup of the fundamental group of a finite graph of groups \mathbb{B} is realizable as a subgraph of groups in some finite-sheeted covering graph of groups \mathbb{C} of the graph of groups \mathbb{B} (for details see 3.75 and seq.). Moreover we will generalize Henry Wilton's result that Limit groups are subgroup separable (see [45]) to towers over f.g. virtually free group:

Definition 4.1. *Let \mathbb{B} be a graph of groups and $k, C \in \mathbb{N}$. We call \mathbb{B} (k, C) -acylindrical, if the action of $G = \pi_1(\mathbb{B}, u_0)$ on (\mathbb{B}, u_0) is (k, C) -acylindrical, i.e. if for any two vertices $v, w \in V(\mathbb{B}, u_0)$ satisfying that the distance of $v, w \in V(\mathbb{B}, u_0)$ is greater than k , we write $d(v, w) > k$, the stabilizer of the segment $[v, w]$ in (\mathbb{B}, u_0) is of order at most C in G .*

Definition 4.11. *Let G be a group and I an index set. We call a family $(A_i)_{i \in I}$ of subgroups of G almost conjugacy separated if $|A_i \cap A_j^g| = \infty$ for some $g \in G$ implies $i = j$.*

Definition 4.12. *We call a finite tree of groups a star of groups if there exists some "midpoint" $u \in VB$ such that $d(u, u') \leq 1$ for any $u' \in VB$.*

Definition 4.20. We call a finite sequence of graphs of groups, $\mathbb{B}^1, \dots, \mathbb{B}^n$, $n \in \mathbb{N}$, a tame tower over the f.g. virtually free group G if the following holds:

1. \mathbb{B}^0 is a finite graph of finite groups satisfying $\pi_1(\mathbb{B}^0, u_0) = G_0 = G$ for some $u_0 \in VB^0$.
2. \mathbb{B}^i , $0 < i \leq n$, is a finite star of groups with midpoint $m^i \in VB^i$ satisfying the following conditions:
 - (a) $B_{m^i}^i = \pi_1(\mathbb{B}^{i-1}, u_0)$ for some $u_0 \in VB^{i-1}$.
 - (b) Let $l \in EB^i$ originating at m^i . Then $\alpha_l(B_l^i)$ is either a finite group or $\alpha_l(B_l^i) = \text{Stab}_G(\text{Axis}(\gamma))$ for some hyperbolic loop $\gamma \in B_{m^i}^i = \pi_1(\mathbb{B}^{i-1}, u_0)$, $u_0 \in VB^{i-1}$. Moreover $B_{\omega(l)}^i$ is subgroup separable and contains only finitely many conjugacy classes of finite groups such that the embedded subgroup $B := \omega_l(B_l^i)$ is normal in $B_{\omega(l)}^i$ satisfying that any two subgroups in B are already conjugate in B whenever they are conjugate in $B_{\omega(l)}^i$.
 - (c) Let $EB^{i,+} := \{l \in EB^i \mid \alpha(l) = m^i \wedge |\alpha_l(B_l^i)| = \infty\}$. Then the family $(\alpha_l(B_l^i))_{l \in EB^{i,+}}$ is almost conjugacy separated for any $i \leq n$.

For any $u_0 \in VB^n$ we call the group $H = \pi_1(\mathbb{B}^n, u_0)$ a tame tower extension of the virtually free group G .

Note that the proofs leading to the following result handle the case of dihedral actions, i.e. the case where the virtually cyclic stabilizer of some Axis in (\mathbb{B}^i, u_0) may acts dihedral on this Axis.

Theorem 4.22. Let $n \in \mathbb{N}$ and $\mathbb{B}^1, \dots, \mathbb{B}^n$ be a tame tower over the virtually free group G . Then \mathbb{B}^n has property \mathcal{L}^+ . In particular any tame tower extension H of a f.g. virtually free group G is subgroup separable.

Note that since the proof of this statement is by induction and the subgroup separability is not strong enough to serve as an inductive hypothesis, we defined the so called property \mathcal{L}^+ which supplements the subgroup separability by some conditions, which were needed for the induction, for details see 4.17.

Definition 4.23. Let G be a group and $A \leq G$. We say A has property \mathcal{C} , if A is maximal virtually abelian and A contains a maximal cyclic subgroup of G of finite index.

In the context of Limit groups extensions of centralizers play an important role. We will generalize this definition as follows:

Definition 4.24.[Virtual extension of a centralizer] *Let G be a group. Suppose that for some $x \in G$ the centralizer $C := C_G(x)$ is abelian and let $D \leq G$ such that D is maximal virtually abelian and D is virtually C . Moreover let A be a group such that there exists an injective homomorphism $\psi : D \rightarrow A$ and $A = \psi(D) \times A'$ with $A' \cong \mathbb{Z}^n$, $n \in \mathbb{N}$. We call the amalgamated product*

$$G(x, A) := G *_{D=\psi(D)} A$$

a virtual extension of the centralizer of x by A with respect to ψ . We call a virtual extension of centralizer special, if the group D has property \mathcal{C} .

Definition 4.25. [(special) iterated virtual extension of a centralizer] *Let G be a group. A (special) iterated virtual extension of centralizers over G is a group H for which there exists a finite series*

$$G \cong G_0 \leq G_1 \leq \dots \leq G_k \cong H$$

*such that for $i = 0, \dots, k-1$, each G_{i+1} is a (special) virtual extension of a centralizer of G_i . We call H a **IVCE-group** of level k or a **SIVCE-group** of level k , accordingly.*

By applying 4.22 we receive the following statement:

Theorem 4.29. *Any SIVCE-group H over some f.g. virtually free group G is subgroup separable.*

We conjecture that any Γ -Limit group is embeddable in some SIVCE-group if Γ is f.g. virtually free. Consequently this would imply that any such Γ -Limit group is subgroup separable since subgroup separability is inherited by subgroups (see [36]).

In [2] the authors introduced the subgroup conjugacy separability (SCS). They proved that free groups and certain virtually free groups are SCS by using covering theory of graph of spaces. The first aim in my research was to prove that any f.g. virtually free group is subgroups conjugacy separable by using covering theory of graphs of groups. While I was working on this topic in [9] the authors proved that any f.g. virtually free group is SCS by using profinite group theory. However we will give an independent proof for this result in chapter 5 based on covering theory of graphs of groups. So we will prove:

Theorem 5.31. *Let G be a f.g. virtually free group. Then G is subgroup conjugacy separable.*

Moreover we will verify that "Fuchsian groups" are SCS:

Definition 6.1. *We call a group G a Fuchsian group if G is a discrete subgroup of $\text{Isom}^+(X)$ for $X \in \{\mathbb{H}^2, \mathbb{R}^2, \mathbb{S}^2\}$.*

The associated quotient space $\mathcal{O} = X/G$ is an orientable 2-dimensional orbifold such that $\pi_1(\mathcal{O}) \cong G$. If G is f.g., we will see that \mathcal{O} can be assumed to be compact and such a compact orientable 2-orbifold can be easily described in the form $\mathcal{O} = (\Sigma_{g(\Sigma)}^n; p_1, \dots, p_m)$ where Σ is a surface of genus $g(\Sigma)$ with n boundary components and $p_i \in \mathbb{N}_{\geq 2}$ are the rotation orders of the so called cone points.

One aim of the last three chapters in this work is to give a proof for the following statement:

Theorem 6.2. *Finitely generated Fuchsian groups are SCS.*

Suppose we are given a f.g. group G , which is either virtually free or a Fuchsian group. In order to prove Theorem 5.31 and Theorem 6.2 we have to verify that any two f.g. non-conjugate subgroups H_1 and H_2 of G remain non-conjugate in a finite quotient of G . Note that it makes sense to treat the case where H_1 and H_2 are finite separately. Thus this case will be discussed in section 5.4. The case where H_1 and H_2 are infinite and G is virtually free will be done in 5.5. For the proof we will basically use covering theory of graphs of groups. Afterwards we deal with the case where H_1 and H_2 are infinite subgroups of the Fuchsian group G . We remark that this case is as well a direct consequence of [8] Theorem 2.6, which was published while I was working on this thesis. However we will give an independent proof, which is based on the ideas of [3], where the authors showed that the fundamental group of a compact closed orientable surface is SCS. For doing this we will observe that subgroups of Fuchsian groups are "almost geometric" as well as subgroups of surface groups are almost geometric (see [36]), which gives rise for using covering theory of 2-dimensional orbifolds in the same style as the authors used covering theory of surfaces in [3].

Afterwards we will use Theorem 6.2 to prove in chapter 9 that fundamental groups of totally orientable compact Seifert 3-manifolds are SCS as well. We define a totally orientable Seifert 3-manifold as follows:

Definition 6.4. *Let M be a Seifert fibered space. M is called totally orientable if there exists a short exact sequence*

$$1 \rightarrow C \rightarrow \pi_1(M) \rightarrow H \rightarrow 1,$$

*such that $H = \pi_1(\mathcal{O})$ for some **orientable** 2-orbifold \mathcal{O} .*

So we will show:

Theorem 6.5. *Let M be a totally orientable Seifert fibered space such that there exists a short exact sequence*

$$1 \rightarrow C \rightarrow \pi_1(M) \rightarrow H \rightarrow 1$$

*with $H = \pi_1(\mathcal{O})$ finitely generated for some **orientable** 2-orbifold \mathcal{O} . Then $\pi_1(M)$ is SCS.*

2 Preliminaries

2.1 Profinite topology

In this chapter we introduce the so called profinite topology and we repeat the definitions of some residual properties. Note that detailed proofs for the mentioned statements in the upcoming discussion about profinite groups can be found in [32]. We will start with the following well known statements.

Definition 2.1. *A neighbourhood basis for a point x of a topological space X is a set of neighbourhoods \mathcal{N} of x such that every open subset U of X containing x contains an N from \mathcal{N} .*

Lemma 2.2. *Let G be a top. group and \mathcal{N} a neighborhood basis of 1_G . Then*

1. *for all $N_1, N_2 \in \mathcal{N}$ there exists an $N' \in \mathcal{N}$ such that $1_G \in N' \subseteq N_1 \cap N_2$;*
2. *for all $N \in \mathcal{N}$ there exists an $N' \in \mathcal{N}$ such that $N'N' \subseteq N$;*
3. *for all $N \in \mathcal{N}$ there exists an $N' \in \mathcal{N}$ such that $N' \subseteq N^{-1}$;*
4. *for all $N \in \mathcal{N}$ and $g \in G$ there exists an $N' \in \mathcal{N}$ such that $N' \subseteq gNg^{-1}$;*
5. *for all $g \in G$, the set $\mathcal{N}_g := \{gN \mid N \in \mathcal{N}\}$ is a neighborhood basis for g .*

Conversly, if G is a group and \mathcal{N} is a nonempty set of subsets of G satisfying (1),(2),(3) and (4), then there is a (unique) topology \mathcal{T} on G for which (5) holds. In addition $U \subseteq G$ is in \mathcal{T} iff for all $g \in U$ there exists an $gN \in \mathcal{N}_g$ such that $gN \subseteq U$. \square

Lemma and Definition 2.3. *Let G be a group and $\mathcal{N} = \{N \trianglelefteq G \mid |G : N| < \infty\}$ be the set of normal subgroups of finite index in G . Then \mathcal{N} satisfies (1),(2),(3) and (4) of Lemma 2.2 and generates a topology on G . With this topology, the so called **profinite topology**, G becomes a topological group. \square*

Note that any family of subgroups of finite index in G , which is closed under taking intersections equips G in the above way with a "profinite" topology. However, if we talk about the profinite topology we mean the before mentioned one.

Suppose we have a group equipped with the **profinite topology**. Then the following hold:

- The leftcosets of all subgroups of finite index in G form a basis of open subsets.
- The rightcosets of all subgroups of finite index in G form a basis of open subsets.
- The cosets of all normal subgroups of finite index in G form a basis of open subsets.
- If G is f.g. (finitely generated), the cosets of all **characteristic** subgroups of finite index in G form a basis of open subsets.

Obviously any group G can be equipped with the profinite topology. If G is finite, the profinite topology and the discrete topology are the same, since $\{1_G\} \in \mathcal{N}$.

2.2 Profinite groups

A profinite group is an inverse limit of an inverse system of finite groups, while the inverse limit (also called the projective limit or limit) is a construction that allows one to "glue together" several related objects, the precise manner of the gluing process being specified by morphisms between the objects. Note that inverse limits can be defined in any category. We start with the following definition:

Definition 2.4.

1. Let (I, \leq) denote a directed partially ordered set or directed poset, that is, I is a set with binary relation \leq satisfying the following conditions:

- $i \leq i$ for $i \in I$;
- $i \leq j$ and $j \leq k$ imply $i \leq k$, for $i, j, k \in I$;
- $i \leq j$ and $j \leq i$ imply $i = j$, for $i, j \in I$; and
- if $i, j \in I$, there exists some $k \in I$ such that $i, j \leq k$.

Let $(G_i)_{i \in I}$ be a family of groups and suppose we have a family of homomorphisms $f_{ij} : G_j \rightarrow G_i$ for all $i \leq j$, called bonding maps, with the following properties:

- (a) f_{ii} is the identity on G_i ,
- (b) $f_{ik} = f_{ij} \circ f_{jk}$ for all $i \leq j \leq k$.

Then the pair $((G_i)_{i \in I}, (f_{ij})_{i \leq j})$ is called an inverse system of groups and morphisms over I , and the morphisms f_{ij} are called the transition morphisms of the system.

2. Let $\prod_{i \in I} G_i$ be the direct product of the groups $(G_i)_{i \in I}$. Then we define the inverse limit of the inverse system $((G_i)_{i \in I}, (f_{ij})_{i \leq j})$ to be the following set

$$\varprojlim_{i \in I} G_i = \left\{ (g_i)_{i \in I} \in \prod_{i \in I} G_i \mid g_i = f_{ij}(g_j) \text{ f.a. } i \leq j \in I \right\} \subseteq \prod_{i \in I} G_i.$$

Moreover it is easily verified that $\varprojlim_{i \in I} G_i$ is a subgroup of $\prod_{i \in I} G_i$.

3. A group G is called a **profinite group** if it is the inverse limit of an inverse system $((G_i)_{i \in I}, (f_{ij})_{i \leq j \in I})$, where G_i is a **finite group** for all $i \in I$.

Remark 2.5. Let $(G_i)_{i \in I}$ a family of finite groups.

1. Equipped with the discrete topology G_i becomes a topological group for all $i \in I$.
2. Under these conditions $\prod_{i \in I} G_i$ equipped with the product topology becomes a topological group.
3. For any $i \in I$ the discrete topological space G_i is obviously totally disconnected, hausdorff and compact. Thus it follows that $\prod_{i \in I} G_i$ is a totally disconnected, hausdorff and compact topological group.

So we are able to prove the following:

Lemma 2.6. Any profinite group is totally disconnected (and hence hausdorff) and compact.

Proof: We have that

$$G = \varprojlim_{i \in I} G_i = \left\{ (g_i)_{i \in I} \in \prod_{i \in I} G_i \mid g_i = f_{ij}(g_j) \text{ f.a. } i \leq j \in I \right\} \leq \prod_{i \in I} G_i.$$

Thus G is a subspace of $\prod_{i \in I} G_i$ and hence totally disconnected and hausdorff.

Since closed subspaces of compact spaces are compact it is left to show that G is closed in $\prod_{i \in I} G_i$. For $i \leq j \in I$ and $g_j \in G_j$ we define the set

$$\left\{ (x_k)_{k \in I} \in \prod_{k \in I} G_k \mid x_j = g_j, x_i \neq f_{ij}(g_j) \right\}.$$

This is an open subset of $\prod_{k \in I} G_k$, since any subset of G_k is open for any $k \in I$. Therefore

$$\bigcup_{g_j \in G_j} \left\{ (x_k)_{k \in I} \in \prod_{k \in I} G_k \mid x_j = g_j, x_i \neq f_{ij}(g_j) \right\} = \left\{ (x_k)_{k \in I} \in \prod_{k \in I} G_k \mid x_i \neq f_{ij}(x_j) \right\}$$

is open in $\prod_{k \in I} G_k$. Thus G is exactly the complement of the open set

$$\bigcup_{i \in I} \bigcup_{j \in I, i \leq j} \left\{ (x_k)_{k \in I} \in \prod_{k \in I} G_k \mid x_i \neq f_{ij}(x_j) \right\}.$$

in $\prod_{k \in I} G_k$. Hence G is closed. □

And for any given topological group G we conclude the following:

Lemma 2.7. *Let G be a topological group. G is a profinite group if G is totally disconnected (and hence hausdorff) and compact.*

Proof: Let $\mathcal{U} = \{U \leq G \mid U \text{ open}\}$. Since G is compact one can verify that $U \in \mathcal{U}$ if and only if U is closed and of finite index in G . So $V_U = \bigcap_{g \in G} gUg^{-1}$ is a normal subgroup of finite index in G for any $U \in \mathcal{U}$. Let $\mathcal{V} = \{V_U \mid U \in \mathcal{U}\}$. There is a canonical way to define an inverse system out of the quotients G/V with $V \in \mathcal{V}$, since the intersection of finitely many of these normal subgroups is also normal in G . Now it is easy to check that the induced map

$$\Psi : G \rightarrow \varprojlim_{V \in \mathcal{V}} G/V$$

is an homeomorphism of topological groups, which proves the claim. □

In "nature" profinite groups arise as Galois groups of infinite Galois extensions of fields. The following result is well-known from Galois-theory.

Theorem 2.8. *If L/K is a finite Galois extension and $G = \text{Gal}(L/K)$ we know that there is a nice one-to-one correspondence*

$$\{\text{Subgroups of } G\} \leftrightarrow \{\text{Intermediate extensions of } L/K\}.$$

To get a similar result for infinite Galois extensions, one can define the following topology on some Galois group G corresponding to some Galois extension L/K . Detailed proofs for the upcoming statements can be found in [20].

Lemma and Definition 2.9. Let $G = \text{Gal}(L/K)$ for some (infinite) Galois extension L/K . And let $\sigma \in G$. Then the set of all leftcosets of the form $\sigma \cdot \text{Gal}(L/F)$ for some finite intermediate Galois extension F/K form a neighborhood basis of σ .

We call the induced topology on G the **Krull topology**. Equipped with this topology G becomes a topological group. \square

Theorem 2.10. If L/K is an infinite Galois extension we get a one-to-one correspondence between the closed subgroups of G and intermediate extensions of L/K , given by the maps

$$H \mapsto \mathcal{F}(H) \text{ and } F \mapsto \text{Gal}(L/F) \leq \text{Gal}(L/K)$$

Furthermore, an intermediate extension F is Galois if and only if the corresponding subgroup H is a normal subgroup of G . Moreover $|L : F|$ is finite if and only if $|G : H|$ is finite. And this is the case if and only if H is open. \square

It is easy to see how the Krull topology induces an inverse system of finite groups in a natural way, since

$$I = \{E : E/K \text{ finite intermediate Galois extension of } L/K\}$$

is a partially ordered set by inclusion. It is a well known fact, that for any $F, E \in I$ with $F \subseteq E$ there exists a surjective homomorphism

$$f_{E,F} : \text{Gal}(E/K) \rightarrow \text{Gal}(F/K); \sigma \mapsto \sigma|_F$$

with $\ker f_{E,F} = \text{Gal}(E/F)$. Thus $(\text{Gal}(E/K)_{E \in I}, (f_{E,F})_{F \subseteq E})$ is an inverse system of finite groups and one can show that the naturally given homomorphism from $\text{Gal}(L/K)$ to the inverse limit of this inverse system is an isomorphism. So we have argued that:

Theorem 2.11. Any Galois group is a profinite group. \square

By a result of W.C. Waterhaus (see [43]) it turns out that the converse is also true:

Theorem 2.12. Any profinite group is a Galois group of some Galois field extension. \square

More precisely he showed that every profinite group is isomorphic to one arising from the Galois theory of **some** field K , but one cannot (yet) control which field K will be in this case. In fact, for many fields K one does not know in general precisely which finite groups occur as Galois groups over K . This problem is called "the inverse Galois problem" for a given field K .

We conclude that for any (infinite) Galois extension the group $G = \text{Gal}(L/K)$ equals its **profinite completion** \hat{G} , which is defined as follows:

Definition 2.13. Let $\mathcal{N} = \{N \trianglelefteq G \mid |G : N| < \infty\}$ and consider the family of finite quotients $(G/N)_{N \in \mathcal{N}}$ of G . Then for any $N_i, N_j \in \mathcal{N}$ satisfying $N_j \leq N_i$ it follows that there exists an epimorphism of finite groups $f_{ij} : G/N_j \rightarrow G/N_i$, $gN_j \mapsto gN_i$ and it is obvious that the pair $((G/N)_{N \in \mathcal{N}}, (f_{ij})_{N_j \leq N_i})$ is an inverse system of finite groups, since the intersection of two normal subgroups of finite index in G is a normal subgroup of finite index in G . We call the the inverse limit

$$\varprojlim_{N \in \mathcal{N}} G/N = \left\{ (g_N N)_{N \in \mathcal{N}} \in \prod_{N \in \mathcal{N}} G/N \mid g_{N_j} N_j \subseteq g_{N_i} N_i \text{ f.a. } N_j \leq N_i \in \mathcal{N} \right\} \leq \prod_{N \in \mathcal{N}} G/N$$

profinite completion of G and we denote it by \hat{G} .

Note that the naturally given homomorphism $G \rightarrow \widehat{G}$ is injective precisely when G has the property that for any non-trivial $g \in G$, there is some $N \trianglelefteq G$ of finite index such that $g \notin N$. Following the next section we call a group satisfying this property residually finite.

2.3 Classical residual properties

There are a few well-known residually properties for groups. Here we give the definitions of these properties. Moreover we will translate any of these properties into the language of the profinite topology of the corresponding group.

Throughout this chapter let $\mathcal{N} = \{N \trianglelefteq G \mid |G : N| < \infty\}$ and $\mathcal{N}_g = \{gN \mid N \in \mathcal{N}\}$ for any $g \in G$.

Definition 2.14. A group G is called **separable** or **residually finite**, if for any $g \in G \setminus \{1_G\}$ there exists a finite group E and a homomorphism $\varphi : G \rightarrow E$ such that $\varphi(g) \neq 1_E$.

An equivalent definition is that for all $x \neq y \in G$ there exists a finite group E and a homomorphism $\phi : G \rightarrow E$ such that $\phi(x) \neq \phi(y)$ in E .

Lemma 2.15. G is separable, if and only if the profinite topology of G is hausdorff.

Proof: " \Rightarrow " If G is separable there exists an $N \in \mathcal{N}$ such that $G/N \cong E$ and $xN \neq yN$ are open sets. Since xN, yN are cosets, we have $xN \cap yN = \emptyset$.

" \Leftarrow " If G is Hausdorff for any $g \in G$ there exists disjoint open subsets U, U' with $1_G \in U$ and $g \in U'$. Since \mathcal{N} is a neighborhood basis of 1_G and $\mathcal{N}_g = \{gN \mid N \in \mathcal{N}\}$ is a neighborhood basis of g by Lemma 2.3, there exists $N \in \mathcal{N}$ and $gN' \in \mathcal{N}_g$ with $N \in U$ and $gN' \in U'$. Since $N'' = N \cap N'$ is normal and of finite index and $g \notin N \supseteq N''$ we have a homomorphism φ from G to the finite group G/N'' with $\varphi(g) \neq 1_{G/N''}$. Hence G is separable. \square

Definition 2.16. A group G is **conjugacy separable** if whenever x and y are non-conjugate elements of G , there exists some finite quotient E of G in which the images of x and y are non-conjugate.

Lemma 2.17. G is conjugacy separable if and only if for any $x \in G$ the set $x^G = \{gxg^{-1} \mid g \in G\}$ is closed in the profinite topology.

Proof: " \Rightarrow " Since G is conjugacy separable for any $y \notin x^G$ there exists $N_y \in \mathcal{N}$ such that $yN_y \cap x^G = \emptyset$. Thus $\bigcup_{y \notin x^G} yN_y$ is an open set since $yN_y \in \mathcal{N}_y$ is open. It follows that $x^G = G \setminus \bigcup_{y \notin x^G} yN_y$. Thus x^G is closed.

" \Leftarrow " Let x^G be a closed subset of G and let $y \notin x^G$. Then there exists $yN \in \mathcal{N}_y$ such that $x^G \cap yN = \emptyset$ since $G \setminus x^G$ is open and \mathcal{N}_y is a neighborhood basis. Therefore the images of x and y are non-conjugate in the finite quotient $E := G/N$. \square

Definition 2.18. A group G is said to be **subgroup separable** if for every finitely generated subgroup $H \leq G$ and $g \in G \setminus H$ there exists a subgroup of finite index $K_g \leq G$ such that $H \leq K_g$ and $g \notin K_g$.

Note that this property is also known as "locally extendable residual finiteness" (LERF). We get the following translation into the language of profinite topology.

Lemma 2.19. *G is subgroup separable if and only if every f.g. subgroup H of G is closed in the profinite topology of G .*

Proof: " \Rightarrow " Let H be a f.g. subgroup of G . For any $g \in G \setminus H$ there exists a finite index subgroup $K_g \leq G$ satisfying $H \leq K_g$ and $g \notin K_g$. Then $\bigcap_{x \in G} xK_gx^{-1}$ is normal and of finite index. Hence K_g is the union of open subsets and consequently open. Since it is additionally of finite index it is closed. Therefore $H = \bigcap_{g \notin H} K_g$ is closed since it is the intersection of closed subsets.

" \Leftarrow " Let $H \leq G$ be closed and $g \in G \setminus H$. Since \mathcal{N}_g is a neighborhood basis and $G \setminus H$ is an open set which contains g , there exists an $gN \in \mathcal{N}_g$ such that $g \in gN \subseteq G \setminus H$. Since $N \trianglelefteq G$ we get $HN \leq G$. Since $H \cap gN = \emptyset$ it follows that $gN \cap HN = \emptyset$. Thus $g \notin K_g := HN$. \square

In this work we are mainly interested in the so called subgroup conjugacy separability:

Definition 2.20. *A group G is called **subgroup conjugacy separable** (SCS) if for any two finitely generated non-conjugate subgroups $H_1, H_2 \leq G$ there exists a homomorphism ϕ from G to a finite group E such that $\phi(H_1)$ is not conjugate to $\phi(H_2)$ in E .*

Lemma 2.21. *Let G be a f.g. group. Then the following statements are equivalent:*

- (1) G is SCS.
- (2) For any two f.g. subgroups $H_1, H_2 \in G$ satisfying that the images $\varphi(H_1)$ and $\varphi(H_2)$ are conjugate in $\varphi(G)$ for any homomorphism φ from G to a finite group E it follows that H_1 and H_2 are already conjugate in G .
- (3) For any two finitely generated subgroups $H_1, H_2 \in G$ the conjugacy of its closures in the profinite completion implies the conjugacy of H_1 and H_2 in G .

Proof: Obviously (1) is equivalent to (2). So it's left to show that (2) is equivalent to (3). Thus it suffices to show that for any two f.g. subgroups $H_1, H_2 \in G$ the images H_1 and H_2 are conjugate in any finite quotient of G if and only if their closures \hat{H}_1 and \hat{H}_2 are conjugate in the profinite completion \hat{G} of G . Note that

$$\hat{H} = \varprojlim_{N \trianglelefteq G} H/N \cap H$$

for any subgroup $H \leq G$. Thus it is immediate that $\hat{H}_1^{\hat{g}} = \hat{H}_2$ for some $\hat{g} \in \hat{G}$ implies that the images of H_1 and H_2 are conjugate in any finite quotient of G . Conversely assume that H_1 and H_2 are conjugate in any finite quotient of G and let $\mathcal{N}_n := \{N \trianglelefteq G \mid |G : N| \leq n\}$ and $N_n := \bigcap_{N \in \mathcal{N}_n} N$. Then N_n is a normal subgroup of finite index, since it is a finite intersection of finite index normal subgroups as G is finitely generated. Let $\mathcal{M} := \{N_n \mid n \in \mathbb{N}\}$ and consider the infinite subfamily $(g_N N)_{N \in \mathcal{M}}$ of $(g_N N)_{N \in \mathcal{N}}$. Note that $(g_N N)_{N \in \mathcal{M}}$ is infinite and for any $N \in \mathcal{N} \supseteq \mathcal{M}$ we find only finitely many elements gN in the finite quotient G/N such that $(H_1 N/N)^{gN} = H_2 N/N$. Thus it follows that there exists $n_1 \in \mathbb{N}$ and an infinite subset $\mathcal{M}_{n_1} \subseteq \mathcal{M}$ such that, after replacing $g_{N_{n_1}} N_{n_1}$ by some suitable element of G/N_{n_1} if necessary, for any $N \in \mathcal{M}_{n_1}$ holds $g_N N_{n_1} = g_{N_{n_1}} N_{n_1}$. Consider the corresponding subfamily $(g_N N)_{N \in \mathcal{M}_{n_1}}$. Let $n_2 \in \mathbb{N}$ satisfying $n_2 > |G : N_{n_1}|$. Then it follows by definition of the subgroups N_n , $n \in \mathbb{N}$, that N_{n_1} contains N_{n_2} as a normal subgroup of finite index. Thus there are only finitely many elements $g' N_{n_2}$ such that

$$(H_1 N_{n_2}/N_{n_2})^{g' N_{n_2}} = H_2 N_{n_2}/N_{n_2} \text{ and } g' N_{n_1} = g_{N_{n_1}} N_{n_1}.$$

Now for any $N_n \in M_{n_1}$ with $n > |G : N_{n_2}|$ it follows that N_n is a subgroup of finite index in N_{n_2} and therefore it follows for such N_n that $g_{N_n} N_{N_{n_2}} = g' N_{n_2} \in G/N_{n_2}$ satisfying

$$(H_1 N_{n_2}/N_{n_2})^{g' N_{n_2}} = H_2 N_{n_2}/N_{n_2} \text{ and } g' N_{n_1} = g_{N_{n_1}} N_{n_1}$$

since the homomorphism $\varphi : G/N_n \rightarrow G/N_{n_1}$ factors through G/N_{n_2} and $N_n \in M_{n_1}$. Thus we find an infinite subset $\mathcal{M}_{n_2} \subseteq \mathcal{M}_{n_1} \setminus \mathcal{N}_{|G:N_{n_1}|}$ such that, after replacing $g_{N_{n_2}} N_{n_2}$ by some suitable element of G/N_{n_2} if necessary, for any $N \in \mathcal{M}_{n_2}$ it follows that $g_N N_{n_2} = g_{N_{n_2}} N_{n_2}$ and $g_N N_{n_1} = g_{N_{n_1}} N_{n_1}$ for any $N \in \mathcal{M}_{n_2}$. Again consider the subsequence $(g_N N)_{N \in \mathcal{M}_{n_2}}$ of $(g_N N)_{N \in \mathcal{M}_{n_1}}$. Proceeding in this manner we are able to construct infinitely many subfamilies $(g_N N)_{N \in \mathcal{M}_{n_i}}$, $i \in \mathbb{N}$, of the original sequence $(g_N N)_{N \in \mathcal{N}}$ such that $(g_N N)_{N \in \mathcal{M}_{n_i}}$ is a subfamily of $(g_N N)_{N \in \mathcal{M}_{n_{i-1}}}$ for any $i \in \mathbb{N}$. Consider now the "diagonal" sequence: $(g_{N_{n_i}})_{i \in \mathbb{N}}$. Clearly $(g_{N_{n_i}} N_{n_i})_{i \in \mathbb{N}}$ is a subfamily of $(g_N N)_{N \in \mathcal{N}}$ satisfying $g_{N_{n_i}} N_i \subseteq g_{N_{n_i}} N_j = g_{N_{n_j}} N_j$ for any $i > j$ with $N_i \subseteq N_j$ and it is obvious how to supplement $(g_{N_{n_i}})_{i \in \mathbb{N}}$ to an element of \hat{G} :

By definition of the normal subgroups N_{n_i} , $i \in \mathbb{N}$, it is possible to choose for any $N \in \mathcal{M} \setminus \{N_{n_i} | i \in \mathbb{N}\}$ some smallest $i \in \mathbb{N}$ such that $N_{n_i} < N$ implying that

$$g_{N_{n_i}} N_{n_i} \subseteq g_{N_{n_i}} N \subseteq g_{N_{n_i}} N_{n_j} = g_{N_{n_j}} N_{n_j}$$

for any $j < i$ satisfying $N < N_{n_j}$. So it is reasonable to set $\hat{g}_N := g_{N_{n_i}}$. Moreover let $\hat{g}_{N_{n_i}} := g_{N_{n_i}}$ for any $i \in \mathbb{N}$. Then it is obvious that the sequence $(\hat{g}_N)_{N \in \mathcal{M}}$ is an element of $\hat{G} \leq \prod_{N \in \mathcal{N}} G/N$, say \hat{g} , and it is easily verified that $\hat{H}_1^{\hat{g}} = \hat{H}_2$. \square

3 Graphs of groups

In the following chapter we will introduce the theory of graphs of groups. The notion of a graph of groups generalizes the notion of amalgamated products and HNN-extension. We will give the needed definitions and discuss some important properties. In particular we will be interested in the fundamental group of a graph of groups. We will discuss two different ways, to define this group for a given graph of groups. Both ways lead to the same group up to isomorphism. Moreover we will see that this group always acts on a tree, the so called Bass-Serre tree, which can be associated to the given graph of groups.

3.1 Graphs of groups and their fundamental groups

We start with the definition of a graph of groups:

Definition 3.1. *A graph of groups \mathbb{A} is a tuple*

$$(A, \{A_v | v \in VA\}, \{A_e | e \in EA\}, \{\alpha_e | e \in EA\}, \{\omega_e | e \in EA\})$$

consisting of a connected graph A and groups A_x for any $x \in VA \cup EA$. These groups are called vertex groups and edge groups, respectively. In addition, the maps $\alpha_e : A_e \rightarrow A_{\alpha(e)}$ and $\omega_e : A_e \rightarrow A_{\omega(e)} = A_{\alpha^{-1}(e)}$ are meant to be monomorphisms with $\omega_e = \alpha_{e^{-1}}$. These maps are called boundary monomorphisms.

As mentioned before, we can associate to any graph of groups \mathbb{A} the fundamental group $\pi_1(\mathbb{A})$. The first way defining this group, immediately implies that amalgamated products and HNN-extensions are special cases of graphs of groups. For completeness, we repeat the definition of a group presentation.

Definition 3.2. *Let X be a set and let $F(X)$ be the free group over the set X . Let $R \subset F(X)$. We say that $\langle X | R \rangle$ is a presentation of the group G , if $G \cong F(X) / \langle\langle R \rangle\rangle$. We call X the set of generators and R the set of defining relations.*

We often write $G = \langle X | R \rangle$ instead of $G = F(X) / \langle\langle R \rangle\rangle$, that means we will not distinguish between the presentation and the presented group.

We give now a first alternative of a definition of the fundamental group of a graph of groups.

Definition 3.3. *Let $A_v = \langle X_v | R_v \rangle$ f.a. $v \in VA$ and $A_e = \langle X_e \rangle$ f.a. $e \in EA$. Let T a maximal subtree of A , that means a subgraph of A , which is a tree containing all vertices of A . We define $\pi_1(\mathbb{A}, T)$ as follows:*

$$\pi_1(\mathbb{A}, T) := \langle \bigcup_{v \in VA} X_v, \{s_e | e \in EA\} | \bigcup_{v \in VA} R_v, N \rangle$$

with

$$N := \{s_e | e \in ET\} \cup \{s_e s_{e^{-1}} | e \in EA\} \cup \{s_e \omega_e(x) s_e^{-1} = \alpha_e(x) | e \in EA, x \in X_e\}.$$

Remark 3.4. *The following properties of the fundamental group are obvious:*

1. *F.a. $e \in ET$ we have $s_e = 1$ in $\pi_1(\mathbb{A}, T)$,*
2. *For any pair of edges $\{e, e^{-1}\} \subset EA \setminus ET$ we have $s_e s_{e^{-1}} = 1$,*

3. For $\{e, e^{-1}\} \in EA$ holds:

$$s_{e^{-1}}\omega_{e^{-1}}(x)s_{e^{-1}}^{-1} = \alpha_{e^{-1}}(x) \Leftrightarrow s_e^{-1}\alpha_e(x)s_e = \omega_e(x) \Leftrightarrow s_e\omega(x)s_e^{-1} = \alpha_e(x).$$

The last property implies that the relation of the last type in the definition is needed only for one edge of any edge pair.

We will now discuss the two special cases of an amalgamated product and an HNN-extension:

Example 3.5. Let \mathbb{A} be a graph groups, s.t. the underlying graph A consists of two vertices v, w and the pair of edges $\{e, e^{-1}\}$ with $\alpha(e) = \omega(e^{-1}) = v$ and $\alpha(e^{-1}) = \omega(e) = w$. Let $A_v = \langle X_v | R_v \rangle$, $A_w = \langle X_w | R_w \rangle$ and $A_e = \langle X_e \rangle$ with boundary morphisms α_e and ω_e . If T is a maximal subtree of A , we have $T = A$ and hence

$$\pi_1(\mathbb{A}, T) = \langle X_v, X_w | R_v, R_w, \{\alpha_e(x) = \omega_e(x) | x \in X_e\} \rangle \cong A_v *_{(\alpha_e, A_e, \omega_e)} A_w.$$

Therefore any amalgamated product can be regarded as a graph of groups. By using Tietze transformationen and the relation $s_e = s_{e^{-1}} = 1$, it is possible to omit the generators s_e and $s_{e^{-1}}$ in the corresponding group presentation.

We now consider the case of an HNN-extension:

Example 3.6. Let \mathbb{A} a graph of groups, s.t. the underlying graph A consists of one vertex v and the pair of edges $\{e, e^{-1}\}$ with $\alpha(e) = \omega(e) = v$. Again let $A_v = \langle X_v | R_v \rangle$, $A_e = \langle X_e \rangle$. If T is a maximal subtree of A , we have $T = v$ and hence

$$\pi_1(\mathbb{A}, T) = \langle X_v, s_e | R_v, \{s_e\alpha_e(x)s_e^{-1} = \omega_e(x) | x \in X_e\} \rangle \cong A_v *_{(\alpha_e, A_e, \omega_e)}.$$

Clearly this is an HNN-extension. Using Tietze transformationen another time and the relation $s_e s_{e^{-1}} = 1$, it is possible to omit the generator $s_{e^{-1}}$ in the corresponding group presentation.

Now we go back to the general case. For the second definition of the fundamental group of a graph of groups \mathbb{A} we need to define the so called \mathbb{A} -paths:

Definition 3.7 (The notion of \mathbb{A} -paths). Let \mathbb{A} be a graph of groups.

1. An \mathbb{A} -path is a sequence of the form

$$p = a_0, e_1, a_1, \dots, e_k, a_k,$$

for a natural number $k \geq 0$, s.t. e_1, \dots, e_k is a path in the underlying graph A connecting some vertex $v \in VA$ with some vertex $v' \in VA$. In addition we have $a_0 \in A_v$, $a_k \in A_{v'}$ and $a_i \in A_{\omega(e_i)} = A_{\alpha(e_{i+1})}$ for $0 < i < k$. The number k is called the length of p and we write $k = |p|$. In the case $k = 0$ we have $v = v'$ and $p = a_0 \in A_v$.

2. Consider some \mathbb{A} -path $p = a_0, e_1, a_1, \dots, e_k, a_k$. Then we call an \mathbb{A} -path of the form $p' = a_i, e_{i+1}, a_{i+1}, \dots, e_j, a_j$ with $0 \leq i \leq j \leq k$ an \mathbb{A} -subpath of p . Let from now on $\Sigma(\mathbb{A})$ be the set of all \mathbb{A} -paths and $\Sigma_v^{v'}(\mathbb{A})$ be the set of all \mathbb{A} -paths originating at v and terminating at v' .

3. Consider two \mathbb{A} -paths $p = a_0, e_1, a_1, \dots, e_k, a_k \in \Sigma_v^{v'}(\mathbb{A})$ and $q = a'_0, e'_1, a'_1, \dots, e'_{k'}, a'_{k'} \in \Sigma_v^{v''}(\mathbb{A})$. Then we define the concatenation $p \cdot q$ of p and q as follows:

$$p \cdot q := a_0, e_1, a_1, \dots, e_k, (a_k \cdot a'_0), e'_1, a'_1, \dots, e'_{k'}, a'_{k'} \in \Sigma_v^{v''}(\mathbb{A})$$

The resulting \mathbb{A} -path $p \cdot q$ connecting v with v'' has the length $|p| + |q|$ and we get an operation:

$$\cdot : \Sigma_v^{v'}(\mathbb{A}) \times \Sigma_v^{v''}(\mathbb{A}) \rightarrow \Sigma_v^{v''}(\mathbb{A}),$$

for $v, v', v'' \in VA$. Most of the time we'll write pq instead of $p \cdot q$.

Clearly we have $\Sigma_v^{v'}(\mathbb{A}) \subseteq \Sigma(\mathbb{A})$. To define the second version of a definition of the fundamental group of a graph of groups \mathbb{A} , we need to define a useful equivalence relation on the set $\Sigma(\mathbb{A})$:

Definition 3.8. Let \mathbb{A} be a graph of groups. Two elements $p, p' \in \Sigma(\mathbb{A})$ are called elementary equivalent, if p' can be emerged from p by one of the following two operations:

1. Replacing an \mathbb{A} -subpath of the form $a, e, \omega_e(c), e^{-1}, \hat{a}$ by $a\alpha(c)\hat{a}$ for $e \in EA, c \in A_e$ and $a, \hat{a} \in A_{\alpha(e)}$. We call this an elementary equivalence of the first type.
2. Replacing an \mathbb{A} -subpath a, e, \hat{a} by $a\alpha_e(c), e, \omega(c)^{-1}\hat{a}$, for $e \in EA, c \in A_e$ and $a, \hat{a} \in A_{\alpha(e)}$. We call this an elementary equivalence of the second type.

We call an elementary equivalence of the first type an elementary reduction since the length of the corresponding \mathbb{A} -path decreases. It follows that, if two elements $p, p' \in \Sigma(\mathbb{A})$ are elementary equivalent, there exists $v, v' \in VA$ such that $p, p' \in \Sigma_v^{v'}(\mathbb{A})$. Therefore, two elementary equivalent \mathbb{A} -paths originate and terminate in the same vertices. We get the following equivalence relation on the set $\Sigma(\mathbb{A})$.

Definition 3.9. Let \mathbb{A} be a graph of groups. Two \mathbb{A} -paths $p, p' \in \Sigma(\mathbb{A})$ are equivalent if there exists a finite sequence of \mathbb{A} -paths $p = p_0, p_1, \dots, p_k = p'$, such that p_{i-1} and p_i are elementary equivalent \mathbb{A} -paths for $1 \leq i \leq k$. We write $p \sim p'$ and denote by $[p]$ the \sim -equivalence class of p .

By the above observation for two elementary equivalent \mathbb{A} -paths, it follows for $p, p' \in \Sigma(\mathbb{A})$ with $p \sim p'$, that $p, p' \in \Sigma_v^{v'}(\mathbb{A})$ for two vertices $v, v' \in VA$. Hence we are able to restrict the equivalence relation \sim on $\Sigma(\mathbb{A})$ to the sets $\Sigma_v^{v'}(\mathbb{A})$ for $v, v' \in VA$. Furthermore it follows that the multiplication defined in Definition 3.7 is compatible with \sim , this means that

$$\cdot : (\Sigma_v^{v'}(\mathbb{A}) / \sim) \times (\Sigma_v^{v''}(\mathbb{A}) / \sim) \rightarrow (\Sigma_v^{v''}(\mathbb{A}) / \sim); [p] \cdot [q] \mapsto [p \cdot q].$$

is a well-defined operation. We will often write $[p] \cdot a_{v'}$ instead of $[p] \cdot [a_{v'}] = [p \cdot a_{v'}]$ for some \mathbb{A} -path p originating at v , terminating at v' and some $a_{v'} \in A_{v'}$.

Let now $v_0 \in VA$. Then it is easy to see that $(\Sigma_{v_0}^{v_0}(\mathbb{A}) / \sim, \cdot)$ is a group with identity element $[1_{A_{v_0}}] \in (\Sigma_{v_0}^{v_0}(\mathbb{A}) / \sim)$. Clearly the inverse element of an element $[p] \in (\Sigma_{v_0}^{v_0}(\mathbb{A}) / \sim)$ with $p = a_0, e_1, a_1, \dots, e_k, a_k$ is given by $[p^{-1}] \in (\Sigma_{v_0}^{v_0}(\mathbb{A}) / \sim)$ where $p^{-1} := a_k^{-1}, e_k^{-1}, \dots, a_1^{-1}, e_1^{-1}, a_0^{-1}$.

This gives rise to the following definition:

Definition 3.10. Let \mathbb{A} be a graph of groups and $v_0 \in VA$. We define the fundamental group of \mathbb{A} to be

$$\pi_1(\mathbb{A}, v_0) := (\Sigma_{v_0}^{v_0}(\mathbb{A}) / \sim, \cdot).$$

By definition the elements of $\pi_1(\mathbb{A}, v_0)$ are the equivalence classes of "closed" \mathbb{A} -paths originating at v_0 and terminating at v_0 . Hence the product of two of these paths gives again an element of $\Sigma_{v_0}^{v_0}(\mathbb{A})/\sim$.

By the following statement the two definitions of the fundamental group of a graph of groups yield the same groups up to isomorphism:

Theorem 3.11. *Let \mathbb{A} be a graph of groups. Then the map*

$$\eta : \pi_1(\mathbb{A}, v_0) \rightarrow \pi_1(\mathbb{A}, T); [a_0, e_1, a_1, \dots, e_k, a_k] \mapsto a_0 s_{e_1} a_1 \dots s_{e_k} a_k$$

is an isomorphism of groups.

Proof: By the definition of the equivalence relation \sim and the given concatenation rule it follows immediately, that η is a well-defined homomorphism. To prove that η is bijective, it suffices to find a map $\theta : \pi_1(\mathbb{A}, T) \rightarrow \pi_1(\mathbb{A}, v_0)$, s.t. $\eta \circ \theta = \text{id}$ and $\theta \circ \eta = \text{id}$. For any vertex $v \in VA$ let $p_v = e_1^v, \dots, e_{m_v}^v$ the unique path connecting v_0 with v in the chosen maximal subtree T of A . In addition let $\bar{p}_v = 1, e_1^v, 1, \dots, 1, e_{m_v}^v, 1$ be the associated \mathbb{A} -path, s.t. only identity elements of the corresponding vertex groups occur in the sequence. We define the operation of θ on the generating set $\bigcup_{v \in VA} X_v, \{s_e | e \in EA\}$ of $\pi_1(\mathbb{A}, T)$ as follows:

1. For $g \in X_v$ for some $v \in VA$ let

$$\theta(g) := [\bar{p}_v, g, \bar{p}_v^{-1}] = [1, e_1^v, 1, \dots, 1, e_{m_v}^v, 1 \cdot g \cdot 1, (e_{m_v}^v)^{-1}, 1, \dots, 1, (e_1^v)^{-1}, 1].$$

2. For s_e with $e \in EA$ we define

$$\begin{aligned} \theta(s_e) &:= [\bar{p}_{\alpha(e)}, s_e, \bar{p}_{\omega(e)}] = \\ &[1, e_1^{\alpha(e)}, 1, \dots, 1, e_{m_v}^{\alpha(e)}, 1, e, 1, (e_{m_v}^{\alpha(e)})^{-1}, 1, \dots, 1, (e_1^{\alpha(e)})^{-1}, 1]. \end{aligned}$$

Extending the map in the natural way to $\pi_1(\mathbb{A}, T)$ induces a homomorphism $\theta : \pi_1(\mathbb{A}, T) \rightarrow \pi_1(\mathbb{A}, v_0)$, which is obviously inverse to η . This proves the bijectivity of η and hence the claim. \square

The following consequence follows now immediately:

Corollary 3.12. *Let \mathbb{A} be a graph of groups, T a maximal subtree of A and $v_0 \in A$. Then the map*

$$\theta : \pi_1(\mathbb{A}, T) \rightarrow \pi_1(\mathbb{A}, v_0)$$

is an isomorphism of groups. \square

Suppose that an \mathbb{A} -path p has a subsequence of the form $a, e, \omega_e(c), e^{-1}, \hat{a}$. We can then perform an elementary reduction to obtain a new \mathbb{A} -path q . Note that $|q| = |p| - 2$ and that $p \sim q$. If no elementary reductions are applicable to p , we say that p is \mathbb{A} -reduced (or just reduced).

Any \mathbb{A} -path is equivalent to a reduced \mathbb{A} -path, and such a reduced \mathbb{A} -path can be obtained by applying elementary reductions as long as possible. The following proposition implies that the reduced \mathbb{A} -path obtained in this way is almost unique.

Proposition 3.13 (Reduced form theorem). *Let \mathbb{A} be a graph of groups and let $p = a_0, e_1, a_1, \dots, e_k, a_k$ and $\bar{p} = \bar{a}_0, \bar{e}_1, \bar{a}_1, \dots, \bar{e}_k, \bar{a}_k$ be reduced \mathbb{A} -paths.*

Then $[p] = [\bar{p}]$ iff $k = \bar{k}$, $\bar{e}_i = e_i$ for $1 \leq i \leq k$ and there exist elements $g_i \in A_{e_i}$ for $1 \leq i \leq k$ such that the following hold.

1. $a_0 = \bar{a}_0 \cdot \alpha_{e_1}(g_1)$.
2. $a_i = \omega_{e_i}(g_i^{-1}) \cdot \bar{a}_i \cdot \alpha_{e_{i+1}}(g_{i+1})$ for $1 \leq i \leq k-1$.
3. $a_k = \omega_{e_k}(g_k^{-1}) \cdot \bar{a}_k$.

Note that this is clearly the same as saying that p can be obtained from \bar{p} by a sequence of elementary equivalences of the second type. Before we proceed with a proof of Proposition 3.13 we record a few immediate consequences.

Corollary 3.14. *Let \mathbb{A} be a graph of groups, $v_0 \in VA$ and $p \in \Sigma_{v_0}^{v_0}(\mathbb{A})$ reduced with $p = a_0, e_1, a_1, \dots, e_k, a_k$. Then it follows $[p] = 1 \in \pi_1(\mathbb{A}, v_0)$ if and only if $|p| = k = 0$ and $a_0 = 1_{A_{v_0}}$. \square*

Corollary 3.15. *Let \mathbb{A} be a graph of groups and $p_{v_0, v} \in \Sigma_{v_0}^v(\mathbb{A})$ for $v, v_0 \in VA$. For any subgroup $A'_v \leq A_v$ the map*

$$\phi : A'_v \rightarrow \pi_1(\mathbb{A}, v_0); \quad g \mapsto [p_{v_0, v} \cdot g \cdot p_{v_0, v}^{-1}]$$

is a monomorphism, s.t. $\text{Im}(\phi) = [p_{v_0, v} \cdot A'_v \cdot p_{v_0, v}]^{-1}$. \square

In a similar way we get:

Lemma 3.16. *Let \mathbb{A} a graph of groups and $p_{v_0, v} \in \Sigma_{v_0}^v(\mathbb{A})$ with $v, v_0 \in VA$. Then the map*

$$\Phi : \pi_1(\mathbb{A}, v_0) \rightarrow \pi_1(\mathbb{A}, v); \quad [p] \mapsto [p_{v_0, v}^{-1} \cdot p \cdot p_{v_0, v}]$$

is an isomorphism of groups.

Proof: Let $[p], [p'] \in \pi_1(\mathbb{A}, v_0)$.

1. We show that Φ is a homomorphism. It holds:

$$\begin{aligned} \Phi([p] \cdot [p']) &= \Phi([p \cdot p']) = [p_{v_0, v}^{-1} \cdot p \cdot p' \cdot p_{v_0, v}] \\ &= [p_{v_0, v}^{-1} \cdot p \cdot p_{v_0, v} \cdot p_{v_0, v}^{-1} \cdot p' \cdot p_{v_0, v}] = \Phi([p]) \cdot \Phi([p']). \end{aligned}$$

2. We have that

$$\begin{aligned} \Phi([p]) &= \Phi([p']) \\ \Leftrightarrow [p_{v_0, v}^{-1} \cdot p \cdot p_{v_0, v}] &= [p_{v_0, v}^{-1} \cdot p' \cdot p_{v_0, v}] \\ \Leftrightarrow [p_{v_0, v}] \cdot [p_{v_0, v}^{-1} \cdot p \cdot p_{v_0, v}] \cdot [p_{v_0, v}^{-1}] &= [p_{v_0, v}] \cdot [p_{v_0, v}^{-1} \cdot p' \cdot p_{v_0, v}] \cdot [p_{v_0, v}^{-1}] \\ \Leftrightarrow [p] &= [p']. \end{aligned}$$

Hence Φ is injective.

3. Let now $[q] \in \pi_1(\mathbb{A}, v)$. Then

$$[q] = [p_{v_0, v}^{-1} \cdot [p_{v_0, v} \cdot q \cdot p_{v_0, v}^{-1}] \cdot p_{v_0, v}] = \Phi([p_{v_0, v} \cdot q \cdot p_{v_0, v}^{-1}]).$$

Therefore Φ is surjective and hence an isomorphism. \square

We give a proof of Proposition 3.13 using "van der Waerden's trick".

Proof of Proposition 3.13: We construct normal forms for elements of $\pi_1(\mathbb{A}, v_0)$, in fact we construct normal forms for all equivalence classes of \mathbb{A} -paths and not only of those that start and end at v_0 .

We say that two \mathbb{A} -paths p and \bar{p} are *strongly equivalent* if they are related as in the conclusion of Proposition 3.13. Thus we want to show that reduced \mathbb{A} -paths are equivalent if and only if they are strongly equivalent. It is clear that strong equivalence is an equivalence relation.

For any $e \in EA$ we choose a set of right coset representatives R_e of $\omega_e(A_e)$ in $A_{\omega(e)}$, thus $A_{\omega(e)} = \bigcup_{r \in R_e} \omega_e(A_e)r$. We choose these sets such that $1 \in R_e$ for all $e \in EA$. We say that an \mathbb{A} -path $p = a_0, e_1, a_1, \dots, e_k, a_k$ is a *normal form* if $a_i \in R_{e_i}$ for $1 \leq i \leq k$. We will show that every equivalence class of \mathbb{A} -paths contains precisely one normal form.

Note first that for any reduced \mathbb{A} -path p we find a reduced \mathbb{A} -path $n(p)$ that is a normal form such that p and $n(p)$ are strongly equivalent; as any equivalence class of \mathbb{A} -paths contains a reduced \mathbb{A} -path this implies that every equivalence class of \mathbb{A} -paths contains at least one normal form.

Before we show the uniqueness of the normal form we observe that it implies the assertion of the proposition. Indeed, suppose that p and \bar{p} are equivalent reduced \mathbb{A} -paths. As before choose normal forms $n(p)$ and $n(\bar{p})$ that are strongly equivalent to p and \bar{p} , respectively. The uniqueness of the normal form implies that $n(p) = n(\bar{p})$. Now p and $n(p)$ and \bar{p} and $n(\bar{p}) = n(p)$ are strongly equivalent which implies that p and \bar{p} are strongly equivalent by transitivity, thus the conclusion of Proposition 3.13 follows.

It remains to show that the normal form is unique, i.e. that any equivalence class of \mathbb{A} -paths contains at most one normal form. For any vertices $v_1, v_2 \in VA$ let $\mathbb{A}(v_1, v_2)$ be set of \mathbb{A} -paths from v_1 to v_2 and $N(v_1, v_2)$ be the set of \mathbb{A} -paths in normal form from v_1 to v_2 . For $v_1, v_2, v_3 \in VA$ we show that there exists a map

$$\theta = \theta_{v_1, v_2, v_3} : \mathbb{A}(v_1, v_2) \times N(v_2, v_3) \rightarrow N(v_1, v_3)$$

such that the following hold:

1. If $p_1 \sim p_2$ then $\theta(p_1, p) = \theta(p_2, p)$.
2. If $p_1 \in \mathbb{A}(v_1, v_2)$ is a normal form and $1 \in N(v_2, v_2)$ then $\theta(p_1, 1) = p_1$.

The existence of such maps clearly implies the uniqueness of normal forms as the existence of two distinct but equivalent normal forms p_1 and p_2 from v_1 to v_2 would imply that both $\theta(p_1, 1) = \theta(p_2, 1)$ (because of 1) and $\theta(p_1, 1) = p_1 \neq p_2 = \theta(p_2, 1)$ (because of 2).

As any \mathbb{A} -path can be written in a unique way as the concatenation of \mathbb{A} -paths $p_1 \cdot \dots \cdot p_l$ where each p_i is of type a with $a \in A_v$ for some $v \in VA$ or of type $1, e, 1$ for some $e \in EA$ it suffices to describe $\theta(p_i, p)$ for the case that p_i is of one of the above types and then extend θ in the obvious way by putting

$$\theta(p_1 \cdot \dots \cdot p_l, p) := \theta(p_1, \theta(p_2 \cdot \dots \cdot p_l, p)).$$

If $a \in A_{v_2}$ and $p = a_0, e_1, a_1, \dots, e_k, a_k \in N(v_2, v_3)$ then we define

$$\theta(a, p) := (aa_0), e_1, a_1, \dots, e_k, a_k$$

which is clearly again a normal form. If $e \in EA$ with $\omega(e) = v_2$ and p as before then choose $\bar{a}_0 \in R_e$ and $c \in \omega_e(A_e)$ such that $c\bar{a}_0 = a_0$. We then put

$$\theta((1, e, 1), p) = \begin{cases} (\alpha_e(c)a_1), e_2, a_2, \dots, e_k, a_k & \text{if } e^{-1} = e_1 \text{ and } \bar{a}_0 = 1 \\ \alpha_e(c), e, \bar{a}_0, e_1, a_1, \dots, e_k, a_k & \text{otherwise.} \end{cases}$$

It follows immediately from the definition that the map θ satisfies condition (2), i.e. that $\theta(p_1, 1) = p_1$ if p_1 is a normal form. To see that condition (1) holds, i.e. that $\theta(p_1, p) = \theta(p_2, p)$ for equivalent p_1 and p_2 it suffices to verify the situations that p_1 and p_2 only differ by one elementary equivalence. In this situation it is a simple exercise where a few cases need to be considered. We leave details to the reader. \square

We will attempt to stick to the following convention: Whenever a graph of groups is denoted by the letter \mathbb{A} or its derivatives like $\bar{\mathbb{A}}$ or \mathbb{A}_i we will refer to its underlying graph by A , \bar{A} and A_i . We further refer to vertex and edge groups by A_v and A_e as in the definition above. If the graph of groups is however denoted by the letter \mathbb{B} or its derivatives then we assume the underlying graph to be the appropriate derivative of B and denote the vertex and edge groups by B_v and B_e .

So both definitions of the fundamental group yield to isomorphic groups. In particular the fundamental group doesn't depend on the choice of the base vertex.

3.2 Bass-Serre theory

In the second part of this chapter we will introduce the Bass-Serre-theory, which establishes the relationship of graph of group theory and group action on simplicial trees. In particular it is possible to find a (nontrivial) graph of group splitting for any group acting (nontrivial) on some simplicial tree. It turns out, that the converse is also true: To any graph of groups it is possible to define a simplicial tree and an action of the fundamental group on this so called Bass-Serre tree. In addition we'll see that both constructions interact in a very useful way.

Definition 3.17. Let $p, p' \in \Sigma_{v_0}(\mathbb{A}) = \bigcup_{v \in VA} \Sigma_v^v(\mathbb{A})$. We call p and p' \approx -equivalent and write $p \approx p'$, if the following properties are satisfied:

1. $p, p' \in \Sigma_v^v(\mathbb{A})$ for some $v \in VA$
2. $p \sim p'a$ for some $a \in A_v$.

Since $p, p' \in \Sigma_v^v(\mathbb{A})$ with $p \sim p'$ implies $p \approx p'$, we denote the \approx -equivalence class of $[p]$ by $[p]A_v$. If now $p \in \Sigma_v^v(\mathbb{A})$, s.t. $p = a_0, e_1, a_1, \dots, e_k, a_k$ it follows that $[p]A_v = [p]a_k^{-1}A_v = [p \cdot a_k^{-1}]A_v$. Therefore there always exists an \mathbb{A} -path p' in the equivalence class $[p]A_v$ of p , s.t. the last element of the sequence p' is 1_{A_v} .

We define the following graph:

Definition 3.18. Let $(\widetilde{\mathbb{A}}, v_0)$ be the graph defined in the following fashion:

1. $V(\widetilde{\mathbb{A}}, v_0) := \{[p]A_v | v \in VA \wedge p \in \Sigma_v^v(\mathbb{A})\}$. That means that the vertices of $(\widetilde{\mathbb{A}}, v_0)$ are exactly the \approx -equivalence classes of \mathbb{A} -paths starting at v_0 .
2. $E(\widetilde{\mathbb{A}}, v_0) := \{([p]A_v, e, [p \cdot a, e, 1_{A'_v}]A_{v'}) | \alpha(e) = v \wedge \omega(e) = v' \wedge a \in A_v\}$. Hence two vertices $x, x' \in V(\widetilde{\mathbb{A}}, v_0)$ are adjacent, if and only if there exists two vertices $v, v' \in VA$, some edge $e \in EA$ and some $a \in A_v$ s.t. $\alpha(e) = v$, $\omega(e) = v'$, $x = [p]A_v$ and $x' = [p']A_{v'}$ with $[p'] = [p \cdot a, e, 1_{A_{v'}}]$.
3. Furthermore we define $(x, e, x')^{-1} := (x', e^{-1}, x)$ to be the involution on the edgeset of $(\widetilde{\mathbb{A}}, v_0)$ for any $(x, e, x') \in E(\widetilde{\mathbb{A}}, v_0)$.

The following statement provides that this graph is a tree:

Theorem 3.19. The graph $(\widetilde{\mathbb{A}}, v_0)$ is a tree. We call it the Bass-Serre tree of (\mathbb{A}, v_0) .

Proof: It suffices to show that any non-trivial closed path $q = f_1, \dots, f_k$ in $(\widetilde{\mathbb{A}}, v_0)$ is not cyclically reduced, i.e. either $f_{i+1} = f_i^{-1}$ for some $1 \leq i \leq k-1$ or that $f_1 = f_k^{-1}$. Put $y_{i-1} = \alpha(f_i)$ for $1 \leq i \leq k$ and represent y_i by a reduced \mathbb{A} -path p_i for $0 \leq i \leq k-1$. Choose i such that the length of p_i is maximal. After a cyclic permutation of the path q we may assume that $i \neq 0$.

As y_i is represented by the reduced path $p_i = a_0, e_1, a_1, \dots, a_{k-1}, e_k, a_k$ and the length of p_i is maximal it follows from the above remark that both y_{i-1} and y_{i+1} are represented by the path $a_0, e_1, a_1, \dots, a_{k-2}, e_{k-1}, a_{k-1}$, i.e. that $y_{i-1} = y_{i+1}$. It further follows that y_{i-1} is joined to y_i by the edge $f_i = (y_{i-1}, e_k, y_i)$ and y_{i+1} is joined to y_i by the edge $f_{i+1}^{-1} = (y_{i+1}, e_k, y_i) = (y_{i-1}, e_k, y_i) = f_i$ which proves the assertion. \square

Remark 3.20. By Definition 3.17 and Proposition 3.13 for any vertex $x \in V(\widetilde{\mathbb{A}}, v_0)$ there exist a reduced \mathbb{A} -path $p = a_0, e_1, a_1, \dots, e_k, 1_{A_v}$ with $k \in \mathbb{N}$ and $v \in VA$, s.t. $x = [p]A_v$. Hence there is a 1-1-correspondence between the edges of the form (x, e, x') and the left cosets of the subgroup $\alpha_e(A_e)$ in A_v for any $e \in EA$ with $\alpha(e) = v$. In particular if T is a system of leftcosetrepresentatives of $\alpha_e(A_e)$ in A_v , there exists for any edge (x, e, x') exactly one $t \in T$ s.t. $x' = [p']A_{v'}$ satisfying $p' = p \cdot t, e, 1_{A_{v'}}$.

Now we are going to show that the fundamental group $\pi_1(\mathbb{A}, v_0)$ of \mathbb{A} acts on $(\widetilde{\mathbb{A}}, v_0)$ in a natural way.

Lemma 3.21. Let \mathbb{A} be a graph of groups. Then the following two operations

$$\pi_1(\mathbb{A}, v_0) \times V(\widetilde{\mathbb{A}}, v_0); [q] \cdot [p]A_v := [qp]A_v,$$

$$\pi_1(\mathbb{A}, v_0) \times E(\widetilde{\mathbb{A}}, v_0); [q] \cdot ([p]A_v, e, [p']A_{v'}) := ([qp]A_v, e, [qp']A'_{v'})$$

induce an action of $\pi_1(\mathbb{A}, v_0)$ on $(\widetilde{\mathbb{A}}, v_0)$ without inversion.

Proof: If $g = [q] \in G$ (where q is an \mathbb{A} -path from v_0 to v_0) and $u = pA_v$ (where p is an \mathbb{A} -path from v_0 to $v \in VA$), then we define

$$g \cdot u = [q] \cdot pA_v := qpA_v.$$

This gives a well-defined action of G on the set of vertices of T . It follows immediately from the definition that this action preserves the adjacency relation, i.e. extends to an action on T by tree automorphisms by putting

$$[q](v, e, v') = ([q]v, e, [q]v')$$

for any edge (v, e, v') of T . Thus G has a natural action on T by automorphisms. This action is without inversion, i.e. for any edge e of T and $g \in G$ we have $ge \neq e^{-1}$. \square

We get the following information about the stabilizers of the vertices and edges:

Lemma 3.22. Let \mathbb{A} be a graph of groups. Let $G = \pi_1(\mathbb{A}, v_0)$ act on $(\widetilde{\mathbb{A}}, v_0)$ as defined above.

1. For any vertex $[p]A_v \in V(\widetilde{\mathbb{A}}, v_0)$ we have

$$\text{Stab}_G([p]A_v) = [p]A_v[p]^{-1}.$$

2. For any edge $\tilde{e} = ([p]A_v, e, [p']A_{v'}) \in E(\widetilde{\mathbb{A}}, v_0)$ s.t. $p' = p, a, e, 1$ for some $a \in A_v$, we get

$$\text{Stab}_G(\tilde{e}) = [p](a\alpha_e(A_e)a^{-1})[p]^{-1} = [p']\omega_e(A_e)[p']^{-1}.$$

3. $\text{Stab}_G(\tilde{e}) = \text{Stab}_G(\alpha(\tilde{e})) \cap \text{Stab}_G(\omega(\tilde{e}))$ for any edge $\tilde{e} \in ET$.

4. $G \cdot [p]A_{\omega(p)} = G \cdot [q]A_{\omega(q)}$ if and only if $\omega(p) = \omega(q)$.

5. $G \cdot ([p_1]A_{\omega(p_1)}, e_1, [q_1]A_{\omega(q_1)}) = G \cdot ([p_2]A_{\omega(p_2)}, e_2, [q_2]A_{\omega(q_2)})$ if and only if $e_1 = e_2$.

Proof: By Proposition 3.13 it is possible to assume that p is reduced.

1. Now it follows by definition that $[p]A_v[p]^{-1} \leq \text{Stab}_G([p]A_v)$. So let $[q] \in \text{Stab}_G([p]A_v)$. Using again Proposition 3.13 we can assume that $q \in \Sigma_{v_0}^{v_0}(\mathbb{A})$ is a reduced \mathbb{A} -path. Since $[q] \in \text{Stab}_G([p]A_v)$, we have that $[q][p]A_v = [qp]A_v = [p]A_v$ and it follows $qp \approx p$. Now by Definition 3.17 there exists some $a \in A_v$ with $qp \sim pa$. Hence $q \sim pap^{-1}$ and we get $[q] = [pap^{-1}] = [p]a[p]^{-1} \in [p]A_v[p]^{-1}$.
2. By definition of the boundary monomorphisms it is easy to see that

$$[p](a\alpha_e(A_e)a^{-1})[p]^{-1} = [p']\omega_e(A_e)[p']^{-1}.$$

The claim follows now by:

$$\begin{aligned} \text{Stab}_G(\tilde{e}) &= \text{Stab}_G([p]A_v) \cap \text{Stab}_G([p']A_{v'}) \\ &\stackrel{!}{=} [p]A_v[p]^{-1} \cap [p']A_{v'}[p']^{-1} \\ &= [p](A_v \cap [a, e, 1]A_{v'}[1, e^{-1}, a^{-1}])[p]^{-1} \\ &= [p](a\alpha_e(A_e)a^{-1})[p]^{-1}. \end{aligned}$$

Note that the last equality follows by the definition of the elementary equivalence of type one, since for any $c \in A_e$ the subpath $a, e, \omega_e(c), e^{-1}, a^{-1}$ is elementary equivalent to the subpath $a\alpha_e(c)a^{-1}$.

3. This is a direct consequence of the 3.21 since $g \cdot (x, e, x') = (gx, e, gx')$ f.a. $g \in G$ and $(x, e, x') \in ET$.
4. Let $[u] \in G$ with $[u][p]A_{\omega(p)} = [up]A_{\omega(p)} = [q]A_{\omega(q)}$. Then it follows $\omega(p) = \omega(up) = \omega(q)$. Thus let $\omega(p) = \omega(q)$. Hence we deduce that pq^{-1} is an \mathbb{A} -path connecting v_0 with v_0 since q^{-1} is an \mathbb{A} -path connecting $\omega(q) = \omega(p)$ with v_0 . Therefore $[pq^{-1}] \in G$ and it follows

$$[p]A_{\omega(p)} = [pq^{-1}q]A_{\omega(q)} = [pq^{-1}][q]A_{\omega(q)} \in G \cdot [q]A_{\omega(q)}.$$

5. Let $[u] \in G$ with

$$[u] \cdot ([p_1]A_{\omega(p_1)}, e_1, [q_1]A_{\omega(q_1)}) = ([up_1]A_{\omega(q_1)}, e_1, [uq_1]A_{\omega(q_1)}) = ([p_2]A_{\omega(p_2)}, e_2, [q_2]A_{\omega(q_2)}).$$

Then $[up_1]A_{\omega(p_1)} = [p_2]A_{\omega(p_2)}$ and $[uq_1]A_{\omega(q_1)} = [q_2]A_{\omega(q_2)}$ implies

$$\alpha(e_1) = \omega(up_1) = \omega(p_2) = \alpha(e_2)$$

and

$$\omega(e_1) = \omega(uq_1) = \omega(q_2) = \omega(e_2).$$

Thus $e_1 = e_2$. For the other implication assume $e_1 = e_2$ and let $v = \alpha(e_1) = \alpha(e_2)$. By definition of $([p_i]A_{\omega(p_i)}, e_i, [q_i]A_{\omega(q_i)})$ there exists $a_i \in A_v$, such that $[q_i]A_{\omega(q_i)} = [p_i(a_i, e_i, 1)]A_{\omega(q_i)}$ for $i \in \{1, 2\}$. Thus we deduce that $[p_1(a_1a_2^{-1})p_2^{-1}] = [p_1(a_1)(p_2(a_2))^{-1}] \in G$ since $p_1(a_1)(p_2(a_2))^{-1}$ is an \mathbb{A} -path connecting v_0 with v_0 and therefore

$$\begin{aligned} &[p_1(a_1a_2^{-1})p_2^{-1}][p_2]A_{\omega(p_2)}, e_2, [q_2]A_{\omega(q_2)} \\ &= ([p_1(a_1a_2^{-1})p_2^{-1}p_2]A_{\omega(p_2)}, e_2, [p_1(a_1a_2^{-1})p_2^{-1}p_2(a_2, e_2, 1)]A_{\omega(q_2)}) \\ &\stackrel{e_1 \equiv e_2}{=} ([p_1(a_1a_2^{-1})]A_{\omega(p_1)}, e_1, [p_1(a_1, e_1, 1)]A_{\omega(q_1)}) \stackrel{Def. \approx}{=} ([p_1]A_{\omega(p_1)}, e_1, [q_1]A_{\omega(q_1)}) \end{aligned}$$

and we conclude $([p_1]A_{\omega(p_1)}, e_1, [q_1]A_{\omega(q_1)}) \in G \cdot ([p_2]A_{\omega(p_2)}, e_2, [q_2]A_{\omega(q_2)})$. \square

We have seen, that any graph of groups induces an action of the fundamental group on the corresponding Bass-Serre tree. On the other hand to any group action of a group G on a simplicial tree, one can find a graph of groups splitting for G and we get the following structure theorem.

Definition 3.23. *Let G and H be groups.*

1. *If G acts on the tree T , we call T a G -tree.*
2. *We say that the G -tree T and the H -tree Y are isomorphic, if there exist an isomorphism of groups $\varphi : G \rightarrow H$ and an isomorphism of graphs $f : T \rightarrow Y$, satisfying*

$$f(gx) = \varphi(g)f(x)$$

for any $g \in G$ and $x \in ET \cup VT$ and we call the pair (φ, f) an isomorphism.

Theorem 3.24 (Structure theorem). *Let G be a group, T a tree, s.t. G acts on T without inversion. Then there exist a graph of groups \mathbb{A} , a vertex $v_0 \in A$ and an isomorphism (φ, f) between the $\pi_1(\mathbb{A}, v_0)$ -tree $(\widetilde{\mathbb{A}}, v_0)$ and the G -tree T .*

Proof: For any $v \in A$ let $p_v = e_{v_1}, \dots, e_{v_{m_v}}$ be the unique reduced path in some chosen maximal subtree $Y \subset A$ joining v_0 and v and $\bar{p}_v = 1, e_{v_1}, 1, \dots, 1, e_{v_{m_v}}, 1$ the associated \mathbb{A} -path. Recall that $\pi_1(\mathbb{A}, v_0)$ is generated by the $[\bar{p}_v A_v \bar{p}_v^{-1}]$ for $v \in VA$ together with the elements $h_e := [\bar{p}_{\alpha(e)}, e, \bar{p}_{\omega(e)}^{-1}]$ for $e \in EA - EY$. We define a homomorphism

$$\varphi : \pi_1(\mathbb{A}, v_0) \rightarrow G$$

by $[\bar{p}_v^{-1} a_v \bar{p}_v] \mapsto a_v$ for all $a_v \in A_v$ and $h_e \mapsto g_e$ for $e \in EA - EY$. It is now a simple exercise to verify that this does indeed extend to a homomorphism. We further define

$$f : (\widetilde{\mathbb{A}}, v_0) \rightarrow T$$

by putting $f(\bar{p}_v A_v) = i(v)$ for all $v \in VY$ and extending this map equivariantly to the set of all vertices by putting

$$f(g \cdot \bar{p}_v A_v) = \varphi(g)f(\bar{p}_v A_v)$$

for all $g \in \pi_1(\mathbb{A}, v_0)$ and $v \in VA$. This map is clearly well-defined and extends to the set of edges as adjacent vertices get mapped to adjacent vertices. Note further that it is immediate that φ is bijective on edge and vertex stabilizers and that it does not identify $\pi_1(\mathbb{A}, v_0)$ -inequivalent vertices or edges.

The φ -equivariance is a trivial consequence of the definition of φ and f . To conclude the proof it therefore suffices to show that f and φ are bijective.

In the follows we denote the image of φ by H , recall that

$$H := \langle \bigcup_{v \in VY} A_v \cup \{g_e \mid e \in EA - EY, \alpha(i(e)) \neq i(\alpha(e))\} \rangle.$$

We first show that f is surjective, it clearly suffices to verify that $H \cdot i(VY) = VT$ as $H \cdot i(VY) = f(V(\widetilde{\mathbb{A}}, v_0))$. Suppose that $H \cdot i(VY) \neq VT$. It follows that there exists an edge $f \in ET$ such that $\alpha(f) \in H \cdot i(VY)$ and $\omega(f) \notin H \cdot i(VY)$. After left multiplication with an element of H we may assume that $\alpha(f) \in i(VY)$. Choose $e \in EA$ such that $G \cdot i(e) = G \cdot f$. It follows from the choice of the elements g_e that either $\alpha(f) = \alpha(i(e))$

or that $g_e \cdot \alpha(f) = \alpha(i(e))$ for some $e \in EA$. Thus either $g \cdot f = i(e)$ or $gg_e \cdot f = i(e)$ for some $g \in \text{Stab } \alpha(i(e)) \leq H$. Thus $f \in H \cdot i(EA)$ and therefore $\omega(f) \in H \cdot i(VY)$, a contradiction.

We will now show that φ is surjective, i.e. that $G = H$. Recall that H contains $A_v = \text{Stab } i(v)$ for all $v \in VY$. Let $g \in G$ and $w \in i(VY)$. As $H \cdot i(VY) = VT$ it follows that there exists $h \in H$ such that $hgw \in i(VY)$. As any two distinct vertices of $i(VY)$ are G -inequivalent and therefore H -inequivalent it follows that $hgw = w$. Thus $g = h^{-1} \cdot hg \in H$ as $hg \in A_w \leq H$, it follows that $G = H$.

To see that f is injective it suffices to verify that f is locally injective. If f is not locally injective then f identifies two edges e_1 and e_2 with $v := \alpha(e_1) = \alpha(e_2)$, in particular $ge_1 = e_2$ for some $g \in \pi_1(\mathbb{A}, v_0)$. Note $\varphi(g) \in \text{Stab } f(e_1) = \text{Stab } f(e_2)$ contradicting the fact that φ is bijective on edge stabilizers. Thus f is a bijection.

It remains to verify that φ is injective. Let $g \in \pi_1(\mathbb{A}, v_0) - 1$. If g acts with a fixed point then $\varphi(g) \neq 1$ as φ is bijective on stabilizers. If g acts without fixed point then $gv \neq v$ for some vertex v and therefore $\varphi(g)f(v) = f(gv) \neq f(v)$ as f is injective. Thus $\varphi(g)$ acts non-trivially on T which implies that $\varphi(g) \neq 1$. \square

A natural notion of equivalence of graphs of groups is that of isomorphism where we say two graphs of groups \mathbb{A} and \mathbb{B} are *isomorphic* and write $\mathbb{A} \sim \mathbb{B}$ if there exists a graph isomorphism $f : A \rightarrow B$, isomorphisms $f_e : A_e \rightarrow B_{f(e)}$ for all $e \in EA$, isomorphisms $f_v : A_v \rightarrow B_{f(v)}$ for all $v \in VA$ and elements $g_e^\alpha \in B_{f(\alpha(e))}$ and $g_e^\omega \in B_{f(\omega(e))}$ with $g_e^\alpha = (g_{e^{-1}}^\omega)^{-1}$ such that

$$f_{\alpha(e)} \circ \alpha_e(g) = g_e^\alpha \cdot (\alpha_{f(e)} \circ f_e(g)) \cdot (g_e^\alpha)^{-1}$$

for any $e \in EA$ and $g \in A_e$. We then call the tuple

$$\mathfrak{f} = (f, \{f_v | v \in VA\}, \{f_e | e \in EA\}, \{g_e^\alpha | e \in EA\}, \{g_e^\omega | e \in EA\})$$

an isomorphism of graphs of groups.

By Theorem 3.24 one can associate to any G -tree T a graph of groups \mathbb{A} with $\pi_1(\mathbb{A}, v_0)$ isomorphic to G and $(\widetilde{\mathbb{A}}, v_0)$ isomorphic to T , s.t. the action of G on T behaves as the action of $\pi_1(\mathbb{A}, v_0)$ on $(\widetilde{\mathbb{A}}, v_0)$. Clearly one expect that two isomorphic group actions on trees yield to isomorphic graph of group splittings. To establish this fact, we need an explicit definition for an isomorphism between graphs of groups:

Definition 3.25. *Let*

$$\mathbb{A} := (A, \{A_v | v \in VA\} \{A_e | e \in EA\} \{\alpha_e | e \in EA\} \{\omega_e | e \in EA\})$$

and

$$\mathbb{B} := (B, \{B_w | w \in VB\} \{B_l | l \in EB\} \{\alpha_l | l \in EB\} \{\omega_l | l \in EB\})$$

two graphs of groups.

We call \mathbb{A} and \mathbb{B} isomorphic, if there exists a tuple

$$\mathfrak{f} = (f, \{f_v | v \in VA\}, \{f_e | e \in EA\}, \{g_e^\alpha | e \in EA\}, \{g_e^\omega | e \in EA\})$$

satisfying the following properties.

1. $f : A \rightarrow B$ is an isomorphism of graphs.
2. $f_e : A_e \rightarrow B_{f(e)}$ is an isomorphism of groups for any $e \in EA$.
3. $f_v : A_v \rightarrow B_{f(v)}$ is an isomorphism of groups for any $v \in EA$.
4. $g_e^\alpha \in B_{f(\alpha(e))}$ and $g_e^\omega \in B_{f(\omega(e))}$, for $g_e^\alpha = (g_{e-1}^\omega)^{-1}$, s.t.

$$f_{\alpha(e)} \circ \alpha_e(c) = g_e^\alpha \cdot (\alpha_{f(e)} \circ f_e(c)) \cdot (g_e^\alpha)^{-1}$$

for any $e \in EA$ and $c \in A_e$.

We call \mathfrak{f} an isomorphism of graphs of groups.

We get the following relationship between isomorphic group actions on trees and isomorphic graphs of groups splittings.

Theorem 3.26. *Let \mathbb{A}^1 and \mathbb{A}^2 be graphs of groups. We define $G_i := \pi_1(\mathbb{A}^i, v_i)$ and $T_i := \widetilde{(\mathbb{A}_i, v_i)}$ for $i \in \{1, 2\}$. Then the following two statements are equivalent:*

1. *The graphs of groups \mathbb{A}^1 and \mathbb{A}^2 are isomorphic.*
2. *The G_1 -tree T_1 is isomorphic to the G_2 -tree T_2 .*

Proof:

(1) \implies (2) Suppose that \mathbb{A}^1 and \mathbb{A}^2 are isomorphic via the isomorphism $\mathfrak{f} = (f, \{f_v | v \in VA^1\}, \{f_e | e \in EA^1\}, \{g_e^\alpha | e \in EA^1\}, \{g_e^\omega | e \in EA^1\})$. To any \mathbb{A}^1 -path $p = a_0, e_1, a_1, e_2, \dots, e_k, a_k$ we can associate the \mathbb{A}^2 -path

$$\mu(p) = [b_0, f(e_1), b_1, f(e_2), \dots, f(e_k), b_k]$$

where $b_0 = f_{\alpha(e_1)}(a_0) \cdot g_{e_1}^\alpha$, $b_k = g_{e_k}^\omega \cdot f_{\omega(e_k)}(a_k)$ and $b_i = g_{e_i}^\omega \cdot f_{\omega(e_i)}(a_i) \cdot g_{e_{i+1}}^\alpha$ for $1 \leq i \leq k-1$. It follows immediately from the definition of a graph of group isomorphism that μ preserves \sim - and \approx -equivalence classes.

Thus the maps $\varphi : \pi_1(\mathbb{A}^1, v_0) \rightarrow \pi_1(\mathbb{A}^2, f(v_0))$, $[p] \mapsto [\mu(p)]$ and $f : V(\widetilde{(\mathbb{A}^1, v_0)}) \rightarrow V(\widetilde{(\mathbb{A}^2, f(v_0))})$, $pA_v^1 \mapsto \mu(p)A_{f(v)}$ are well defined. It is easily checked that f extends to a graph morphism $f : (\mathbb{A}^1, v_0) \rightarrow (\mathbb{A}^2, f(v_0))$, that φ is a homomorphism and that $f(gx) = \varphi(g)f(x)$ for all $x \in ET_1 \cup VT_1$. The surjectivity of f and φ are obvious, the injectivity follows as reduced \mathbb{A}^1 -paths get mapped to reduced \mathbb{A}^2 -paths.

(2) \implies (1) We may assume that $G = G_1 = G_2$ and $T = T_1 = T_2$. Clearly the graphs A^1 and A^2 underlying \mathbb{A}^1 and \mathbb{A}^2 are isomorphic, we may assume that $A = A^1 = A^2$. Moreover there exists a maps $j_V^i : VA \rightarrow VT$ and $j_E^i : AE \rightarrow TE$ for $i = 1, 2$ and elements $g_e \in G$ for $e \in EA$ and $g_v \in G$ for $v \in VA$ such that the following hold:

1. $A_v^i = \text{Stab } j_V^i(v)$ for $v \in VA$ and $i = 1, 2$ and $j_V^2(v) = g_v \cdot j_V^1(v)$ for $v \in VA$.
2. $A_e^i = \text{Stab } j_E^i(e)$ for $e \in EA$ and $i = 1, 2$ and $j_E^2(e) = g_e \cdot j_E^1(e)$ for $e \in EA$.

Moreover there exists element g_e^i for $e \in EA$ and $i = 1, 2$ such that

$$g_e^i \cdot \alpha(j_E^i(e)) = j_V^i(\alpha(e)) \text{ and } \alpha_e^i : A_e^i \rightarrow A_{\alpha(e)}^i \text{ is given by } a \mapsto g_e^i a (g_e^i)^{-1}$$

for $e \in EA$ and $i = 1, 2$. It is now a straight forward computation to check that $\mathbf{f} = (id_A, \{f_v | v \in VA^1\}, \{f_e | e \in EA^1\}, \{g_e^\alpha | e \in EA^1\}, \{g_e^\omega | e \in EA^1\})$ defines an isomorphism $\mathbf{f} : \mathbb{A}^1 \rightarrow \mathbb{A}^2$ if

1. $f_v : A_v^1 \rightarrow A_v^2$ is given by $a \mapsto g_v a g_v^{-1}$ for $v \in VA$.
2. $f_e : A_e^1 \rightarrow A_e^2$ is given by $a \mapsto g_e a g_e^{-1}$ for $e \in EA$.
3. $g_e^\alpha = (g_{e^{-1}}^\omega)^{-1} = g_e^2 \cdot g_e \cdot (g_e^1)^{-1} \cdot g_e^{-1} \in A_v^2$ for all $e \in EA$. □

3.3 Folded morphisms and covers of graphs of groups

In the last chapter, we have seen, that a G -tree T is isomorphic to a H -tree Y if and only if the corresponding graph of groups decompositions of G and H are isomorphic. A similar statement is also true for so called graph of group morphisms.

3.3.1 Morphisms of graphs of groups

Definition 3.27. A morphism between a G -tree T and a H -tree Y is a pair (φ, f) , s.t. $\varphi : G \rightarrow H$ is a homomorphism of groups and $f : T \rightarrow Y$ is a graph morphism with the property that $\varphi(g)f(x) = f(gx)$ f.a. $g \in G$ and $x \in ET \cup VT$.

The analogon of this definition in the language of graphs of groups can be expressed as follows:

Definition 3.28. A morphism between two graphs of groups

$$\mathbb{A} := (A, \{A_v | v \in VA\}, \{A_e | e \in EA\}, \{\alpha_e | e \in EA\}, \{\omega_e | e \in EA\})$$

and

$$\mathbb{B} := (B, \{B_w | w \in VB\}, \{B_l | l \in EB\}, \{\alpha_l | l \in EB\}, \{\omega_l | l \in EB\})$$

is a tuple

$$\mathfrak{f} = (f, \{f_v | v \in VA\}, \{f_e | e \in EA\}, \{g_e^\alpha | e \in EA\}, \{g_e^\omega | e \in EA\})$$

satisfying the following properties:

1. $f : A \rightarrow B$ is a graph morphism.
2. $f_e : A_e \rightarrow B_{f(e)}$ is a homomorphism of groups f.a. $e \in EA$.
3. $f_v : A_v \rightarrow B_{f(v)}$ is a homomorphism of groups f.a. $v \in EA$.
4. $g_e^\alpha \in B_{f(\alpha(e))}$ and $g_e^\omega \in B_{f(\omega(e))}$, with $g_e^\alpha = (g_{e^{-1}}^\omega)^{-1}$, s.t.

$$f_{\alpha(e)} \circ \alpha_e(c) = g_e^\alpha \cdot (\alpha_{f(e)} \circ f_e(c)) \cdot (g_e^\alpha)^{-1}$$

for all $e \in EA$ and $c \in A_e$.

If now $\mathfrak{f} : \mathbb{A} \rightarrow \mathbb{B}$ is a morphism of graphs of groups, it is possible to associate to any \mathbb{A} -path $p \in \Sigma(\mathbb{A})$ a \mathbb{B} -path $\mu(p) \in \Sigma(\mathbb{B})$ if we set

$$\mu(p) := [b_0, f(e_1), b_1, f(e_2), \dots, f(e_k), b_k]$$

with $b_0 = f_{\alpha(e_1)}(a_0) \cdot g_{e_1}^\alpha$, $b_k = g_{e_k}^\omega \cdot f_{\omega(e_k)}(a_k)$ and $b_i = g_{e_i}^\omega \cdot f_{\omega(e_i)}(a_i) \cdot g_{e_{i+1}}^\alpha$ for $1 \leq i \leq k-1$. Therefore we get a well-defined map

$$\mu : \Sigma(\mathbb{A}) \rightarrow \Sigma(\mathbb{B}); p \mapsto \mu(p).$$

The target is now, to create a homomorphism of the corresponding fundamental groups and a graph morphism on the tree level.

Lemma 3.29. Let $p, p' \in \Sigma(\mathbb{A})$ with $[p] = [p']$. Then $[\mu(p)] = [\mu(p')] \in \Sigma(\mathbb{B}) / \sim$. Hence the images of two equivalent \mathbb{A} -paths are two equivalent \mathbb{B} -paths.

Proof: [44], Lemma 6.1.5. □

Hence we get the well-defined map

$$\varphi_{\mathfrak{f}} : \pi_1(\mathbb{A}, v_0) \rightarrow \pi_1(\mathbb{B}, f(v_0)), [p] \mapsto [\mu(p)].$$

It is easily verified that this map is a homomorphism of groups. Similarly it follows that the map

$$V(\widetilde{\mathbb{A}}, v_0) \rightarrow V(\widetilde{\mathbb{B}}, f(v_0)); [p]A_v \mapsto [\mu(p)]B_{f(v)}$$

is well-defined and $\varphi_{\mathfrak{f}}$ -equivariant. Clearly we can extend this map to a $\varphi_{\mathfrak{f}}$ -equivariant graph morphism

$$\mathfrak{f}_{\mathfrak{f}} : (\widetilde{\mathbb{A}}, v_0) \rightarrow (\widetilde{\mathbb{B}}, f(v_0)).$$

This proves the first part of the following Theorem:

Theorem 3.30. *Let \mathbb{A}, \mathbb{B} be graphs of groups.*

1. *Let $\mathfrak{f} : \mathbb{A} \rightarrow \mathbb{B}$ be a morphism. The pair $(\varphi_{\mathfrak{f}}, \mathfrak{f}_{\mathfrak{f}})$ defines a morphism between the $\pi_1(\mathbb{A}, v_0)$ -tree $(\widetilde{\mathbb{A}}, v_0)$ and the $\pi_1(\mathbb{B}, f(v_0))$ -tree $(\widetilde{\mathbb{B}}, f(v_0))$, with $\mathfrak{f}_{\mathfrak{f}}(\tilde{v}_0) = \tilde{f}(v_0)$.*
2. *Moreover for any morphism (φ, \tilde{f}) from the $\pi_1(\mathbb{A}, v_0)$ -tree $(\widetilde{\mathbb{A}}, v_0)$ to the $\pi_1(\mathbb{B}, f(v_0))$ -tree $(\widetilde{\mathbb{B}}, f(v_0))$ there exists $\mathfrak{f} : \mathbb{A} \rightarrow \mathbb{B}$ such that $(\varphi, \tilde{f}) = (\varphi_{\mathfrak{f}}, \mathfrak{f}_{\mathfrak{f}})$.*

Proof: It remains to show the second assertion.

Suppose that (φ, \tilde{f}) is a morphism from the $\pi_1(\mathbb{A}, v_0)$ -tree $(\widetilde{\mathbb{A}}, v_0)$ to the $\pi_1(\mathbb{B}, u_0)$ -tree $(\widetilde{\mathbb{B}}, u_0)$ such that $\tilde{f}(\tilde{v}_0) = \tilde{u}_0$, we need to construct \mathfrak{f} such that $(\varphi, \tilde{f}) = (\varphi_{\mathfrak{f}}, \mathfrak{f}_{\mathfrak{f}})$. It is trivial that \tilde{f} induces a morphism $f : A \rightarrow B$ as $\pi_1(\mathbb{A}, v_0)$ -orbits of vertices and edges are mapped to $\pi_1(\mathbb{B}, u_0)$ -orbits of vertices and edge.

Choose a maximal tree $Y \subset A$ and for each $v \in VA$ let $p_v = e_{v_1}, \dots, e_{v_{m_v}}$ be the reduced path in Y from v_0 to v and $\bar{p}_v = 1, e_{v_1}, 1, \dots, 1, e_{v_{m_v}}, 1$ be the corresponding \mathbb{A} -path. Let further $\tilde{v} := \bar{p}_v A_v$. Recall that

$$\tilde{V} := \{\tilde{v} \mid v \in VA\}$$

contains a unique representative of each $\pi_1(\mathbb{A}, v_0)$ -orbit in $V(\widetilde{\mathbb{A}}, v_0)$. Thus it suffices to construct \mathfrak{f} such that $\varphi_{\mathfrak{f}} = \varphi$ and that $\mathfrak{f}_{\mathfrak{f}}(\tilde{v}) = \tilde{f}(\tilde{v})$ for all $\tilde{v} \in \tilde{V}$.

For each $v \in VA$ choose a \mathbb{B} -path $\bar{q}_v = b_0^v, f(e_{v_1}), b_1^v, \dots, b_{m_v-1}^v, f(e_{v_{m_v}}), 1$ in normal form such that $\tilde{f}(\tilde{v}) = \bar{q}_v \cdot B_{f(v)}$. As φ maps $\text{Stab}(\tilde{v}) = \bar{p}_v \cdot A_v \cdot \bar{p}_v^{-1}$ homomorphically to

$$\text{Stab}\tilde{f}(\tilde{v}) = \bar{q}_v \cdot B_{f(v)} \cdot \bar{q}_v^{-1}$$

we can choose $f_v : A_v \rightarrow B_{f(v)}$ such that

$$\varphi(\bar{p}_v \cdot a \cdot \bar{p}_v^{-1}) = \bar{q}_v \cdot f_v(a) \cdot \bar{q}_v^{-1}.$$

For any $e \in EA$ that occurs as some e_{v_i} we put $g_e^\alpha = g_{e_{i-1}}^\omega = b_{i-1}^v$ and $g_e^\omega = g_{e_{i-1}}^\alpha = 1$. This is well defined as the \bar{q}_v are in normal form which implies that for $e_{v_i} = e_{v'j}$ we have

$b_{i-1}^v = b_{j-1}^{v'}$ (and in fact $i = j$). Note that the data defined so far implies that $f_{\mathfrak{f}}(\tilde{v}) = \tilde{f}(\tilde{v})$ for all $\tilde{v} \in \tilde{V}$ and that $\varphi_{\mathfrak{f}}(\bar{p}_v \cdot a \cdot \bar{p}_v^{-1}) = \varphi(\bar{p}_v \cdot a \cdot \bar{p}_v^{-1})$ for all $a \in A_v$.

We still need to define the elements g_e^α and g_e^ω in the case that e is an edge of $EA - EY$. Thus let $\{e, e^{-1}\}$ be an edge pair in $EA - EY$. We need to define the g_e^α and g_e^ω such that

$$\varphi_{\mathfrak{f}}([\bar{p}_{\alpha(e)}, e, \bar{p}_{\omega(e)}^{-1}]) = \varphi([\bar{p}_{\alpha(e)}, e, \bar{p}_{\omega(e)}^{-1}]).$$

As $[\bar{p}_{\alpha(e)}, e, \bar{p}_{\omega(e)}^{-1}] \cdot \bar{p}_{\omega(e)} A_{\omega(e)} = \bar{p}_{\alpha(e)} \cdot e \cdot A_{\omega(e)}$ it follows that

$$\varphi([\bar{p}_{\alpha(e)}, e, \bar{p}_{\omega(e)}^{-1}]) \cdot f(\bar{p}_{\omega(e)} A_{\omega(e)}) = f(\bar{p}_{\alpha(e)} \cdot e \cdot A_{\omega(e)})$$

and therefore

$$\varphi([\bar{p}_{\alpha(e)}, e, \bar{p}_{\omega(e)}^{-1}]) \cdot \bar{q}_{\omega(e)} B_{f(\omega(e))} = \bar{q}_{\alpha(e)} \cdot b \cdot f(e), B_{f(\omega(e))}$$

for some $b \in B_{\alpha(f(e))}$. Thus $\varphi([\bar{p}_{\alpha(e)}, e, \bar{p}_{\omega(e)}^{-1}]) = \bar{q}_{\alpha(e)} \cdot b \cdot f(e), b' \cdot \bar{q}_{\omega(e)}^{-1}$ for some $b' \in B_{\omega(f(e))}$. Thus we need to put $g_e^\alpha = b$ and $g_e^\omega = b'$.

It remains to check that the data given is part of morphism, in particular we need to define the $f_e : A_e \rightarrow B_{f(e)}$ appropriately. By the definition of a morphism we need to define $f_e(c) = \alpha_{f(e)}^{-1}((g_e^\alpha)^{-1} \cdot f_{\alpha(e)} \circ \alpha_e(c) \cdot g_e^\alpha)$ for all $c \in A_e$. It is a straight forward calculation to check that this defines a morphism. \square

3.3.2 Folded morphisms of graphs of groups

If we are given a graph of groups \mathbb{B} , we are mainly interested in the morphisms $\mathfrak{f} : \mathbb{A} \rightarrow \mathbb{B}$, for which $\varphi_{\mathfrak{f}}$ is an injective map. Since in this case, we have that $\pi_1(\mathbb{A}, v_0) \cong \text{Im}(\varphi_{\mathfrak{f}}) \leq \pi_1(\mathbb{B}, f(v_0))$. The target is known, to verify, in which cases we have that $\varphi_{\mathfrak{f}}$ is an injective map.

Definition 3.31. *Let $\mathfrak{f} : \mathbb{A} \rightarrow \mathbb{B}$ be a morphism of graphs of groups.*

1. \mathfrak{f} is called *injective/surjective/bijective on vertices*, if $f_v : A_v \rightarrow B_{f(v)}$ is *injective/surjective/bijective* f.a. $v \in VA$. This is equivalent to the property that $\varphi_{\mathfrak{f}}|_{\widetilde{\text{Stab}}_G(x)}$ is *injective/surjective/bijective* f.a. $x \in V(\widetilde{\mathbb{A}}, v_0)$.
2. We say that \mathfrak{f} and the pair $(\varphi_{\mathfrak{f}}, f_{\mathfrak{f}})$, respectively is π_1 -*injective/surjective/bijective*, if $\varphi_{\mathfrak{f}}$ is *injective/surjective/bijective*.
3. \mathfrak{f} and $(\varphi_{\mathfrak{f}}, f_{\mathfrak{f}})$, respectively is called *locally injective*, if $f_{\mathfrak{f}}$ is *locally injective*.
4. We say \mathfrak{f} and $(\varphi_{\mathfrak{f}}, f_{\mathfrak{f}})$, respectively is *folded*, if \mathfrak{f} is *injective on vertices and locally injective*.
5. We call \mathfrak{f} an *isomorphism of graphs of groups* if the map f is an *isomorphism of graphs* and the homomorphism f_x is an *isomorphism* for any $x \in VA \cup EA$.
6. We call \mathfrak{f} an *automorphism* if \mathfrak{f} is an *isomorphism of graphs of groups* and $\mathbb{A} = \mathbb{B}$.

Theorem 3.32. *Let $\mathfrak{f} : \mathbb{A} \rightarrow \mathbb{B}$ be a folded morphism of graphs of groups. Then the maps $\varphi_{\mathfrak{f}}$ and $f_{\mathfrak{f}}$ are injective.*

Proof: [44], Lemma 6.5. □

The following Lemma provides now a criterion, when a morphism is folded.

Lemma 3.33. *Let $\mathfrak{f} : \mathbb{A} \rightarrow \mathbb{B}$ be a morphism of graphs of groups. Then \mathfrak{f} is folded if and only if **non** of the following properties is satisfied:*

1. \mathfrak{f} is not injective on vertices.
2. There exists $e_1, e_2 \in EA$ with $e_1 \neq e_2$ and $\alpha(e_1) = \alpha(e_2) =: v$, s.t. $f(e_1) = f(e_2) =: l$ and

$$g_{e_1}^\alpha \cdot \alpha_l(B_l) = f_v(a) \cdot g_{e_2}^\alpha \cdot \alpha_l(B_l)$$

for some $a \in A_v$.

3. There exists $e \in EA$ and $a \in A_{\alpha(e)} \setminus \alpha_e(A_e)$, s.t.

$$f_{\alpha(e)}(a) \cdot g_e^\alpha \cdot \alpha_{f(e)}(B_{f(e)}) = g_e^\alpha \cdot \alpha_{f(e)}(B_{f(e)})$$

Proof: [44], Lemma 6.6. □

Definition 3.34. *Let \mathbb{B} be a graph of groups.*

1. An action of a group G on a tree T is called minimal, if there exists no proper G -invariant subtree of T .
2. A graph of groups \mathbb{B} is said to be minimal, if the induced action of $G = \pi_1(\mathbb{B}, u_0)$ for some (and hence for all) $u_0 \in VB$ on the Bass-Serre tree $\widetilde{(\mathbb{B}, u_0)}$ is minimal.

Clearly for any graph of groups \mathbb{B} , there exists a minimal graph of groups \mathbb{B}' such that $\pi_1(\mathbb{B}, u_0) \cong \pi_1(\mathbb{B}', u'_0)$. Hence from now on we will assume that \mathbb{B} is a minimal graph of groups.

By the following result any subgroup of the fundamental group of a graph of groups can be represented by a folded morphism of graphs of groups.

Theorem 3.35. *Let \mathbb{B} be a graph of groups, $G := \pi_1(\mathbb{B}, u_0)$ for some $u_0 \in VB$ and $U \leq G$. Then there exists a graph of groups \mathbb{A} and a folded graphs of groups morphism $\mathfrak{f} : \mathbb{A} \rightarrow \mathbb{B}$, s.t. $U = \varphi_{\mathfrak{f}}(\pi_1(\mathbb{A}, v_0))$.*

Remark 3.36. *Note that Theorem 3.35 is a generalization of Kurosh's Theorem, which says that any subgroup of a free product $\mathbb{A} * B$ can be realized as a free product of a free group and some conjugates of the groups A and B .*

Proof of Theorem 3.35: Since $U \leq \pi_1(\mathbb{B}, u_0)$ acts on the Bass-Serre tree $\widetilde{(\mathbb{B}, u_0)}$, by Theorem 3.24 there exists a graph of groups \mathbb{A} and some vertex $v_0 \in VA$, s.t. there exists an isomorphism between the $\pi_1(\mathbb{A}, v_0)$ -tree $\widetilde{(\mathbb{A}, v_0)}$ and the U -tree $\widetilde{(\mathbb{B}, u_0)}$. This induces a morphism (φ, \tilde{f}) from the $\pi_1(\mathbb{A}, v_0)$ -tree $\widetilde{(\mathbb{A}, v_0)}$ to the $\pi_1(\mathbb{B}, u_0)$ -tree $\widetilde{(\mathbb{B}, u_0)}$, s.t.

$$\varphi : \pi_1(\mathbb{A}, v_0) \rightarrow \pi_1(\mathbb{B}, u_0)$$

is a monomorphism with $\text{Im}(\varphi) = U$ and

$$\tilde{f} : \widetilde{(\mathbb{A}, v_0)} \rightarrow \widetilde{(\mathbb{B}, u_0)}$$

is a graph isomorphism. Therefore by Theorem 3.30 there exists a morphism between the corresponding graphs of groups, that means there exists $\mathfrak{f} : \mathbb{A} \rightarrow \mathbb{B}$, s.t. $\varphi_{\mathfrak{f}} = \varphi$ and $f_{\mathfrak{f}} = \tilde{f}$. Assume that $f_v : A_v \rightarrow B_{f(v)}$ is not injective for some $v \in VA$. Then there exists $a \in A_v$, s.t. $f_v(a) = 1_{A_{f(v)}}$. So let $p_{v_0, v} \in \Sigma_{v_0}^v(\mathbb{A}, v_0)$. Since $1 \neq a \in \Sigma_v^v(\mathbb{A})$ by Corollary 3.15 it follows that $[p_{v_0, v} \cdot a \cdot p_{v_0, v}^{-1}] \neq 1_{\pi_1(\mathbb{A}, v_0)}$. Furthermore

$$\begin{aligned} \varphi_{\mathfrak{f}}([p_{v_0, v} \cdot a \cdot p_{v_0, v}^{-1}]) &= [\mu(p_{v_0, v} \cdot a \cdot p_{v_0, v})] = [\mu(p_{v_0, v})] \cdot f_v(a) \cdot [\mu(p_{v_0, v})]^{-1} \\ &= [\mu(p_{v_0, v})] \cdot 1_{A_{f(v)}} \cdot [\mu(p_{v_0, v})]^{-1} = 1_{\pi(\mathbb{B}, u_0)} \in U. \end{aligned}$$

This contradicts the fact that $\varphi_{\mathfrak{f}} = \varphi$ is injective. Hence we have that \mathfrak{f} is injective on vertices. Since $f_{\mathfrak{f}} = \tilde{f}$ is a isomorphisms of graphs, it follows that $f_{\mathfrak{f}}$ is locally injective. We conclude that $\mathfrak{f} : \mathbb{A} \rightarrow \mathbb{B}$ is a folded graph of group morphism. \square

Since the morphism $\mathfrak{f} : \mathbb{A} \rightarrow \mathbb{B}$ constructed in Theorem 3.35 is folded and and the induced map $f_{\mathfrak{f}} : \widetilde{(\mathbb{A}, v_0)} \rightarrow \widetilde{(\mathbb{B}, u_0)}$ is an isomorphism of graphs, any subgroup can be represented by a "cover" of graphs of groups in the sense of the following definition.

3.3.3 Covers of graphs of groups

In 1993 Hyman Bass introduced in his work "Covering theory for graphs of groups", see [1], coverings of graphs of groups. Although he uses a different notation, his definition is equivalent to the one we will give in this section (see chapter 2 of [1]). Moreover he turns from "local" properties to "global" properties, i.e. his definition of a covering of graphs of groups $\mathfrak{f} : \mathbb{A} \rightarrow \mathbb{B}$ depends on local properties and he concludes some equivalent global properties of the maps $\varphi_{\mathfrak{f}}$ and $f_{\mathfrak{f}}$. Our (equivalent) definition is the following:

Definition 3.37 (Coverings of graphs of groups). *Let $\mathfrak{f} : \mathbb{A} \rightarrow \mathbb{B}$ be a morphism of two graphs of groups \mathbb{A} und \mathbb{B} . We call \mathfrak{f} a covering (or cover), if \mathfrak{f} is folded and the induced map $f_{\mathfrak{f}} : \widetilde{(\mathbb{A}, v_0)} \rightarrow \widetilde{(\mathbb{B}, f(v_0))}$ is an isomorphism of graphs.*

Thus our definition includes the "local" property that $\mathfrak{f} : \mathbb{A} \rightarrow \mathbb{B}$ is folded and the global property that $f_{\mathfrak{f}}$ is an isomorphism. Note that in section 3.5 we will give an equivalent definition of a covering of graphs of groups, which only depends on local properties. Moreover this definition will only vary by the way of notation from the one given in Deefinon 2.6 [1].

Not for any subgroup $U \leq G = \pi_1(\mathbb{B}, u_0)$, we have that the corresponding graph of groups \mathbb{A} , constructed in Theorem 3.35, is minimal (see Definition 3.34.2). The following Lemma shows, that \mathbb{A} is minimal if \mathbb{B} is minimal and the represented subgroup U has finite index in G .

Recall the following:

Remark 3.38. *Let G be a group acting on a tree T .*

1. *If $g, h \in G$ are hyperbolic with disjoint axes $\text{Axis}(g)$ and $\text{Axis}(h)$, then the element gh is hyperbolic and its axis contains the unique shortest arc from $\text{Axis}(g)$ to $\text{Axis}(h)$.*
2. *If G contains hyperbolic elements, then the union of the axes of such elements is the unique minimal G -invariant subtree of T .*

Proof: Observe that it suffices to show the first assertion, since the second assertion is a direct consequence of the first. For the first assertion let e be an edge in the arc joining $\text{Axis}(g)$ to $\text{Axis}(h)$ and let X and Y be the components of $T \setminus \{e\}$ containing $\text{Axis}(g)$ and $\text{Axis}(h)$ respectively, then $g^{\pm 1}(Y \cup \{e\}) \subseteq X$ while $h^{\pm 1}(X \cup \{e\}) \subseteq Y$. It follows that e lies in the geodesic from $(gh)^{-n}(e)$ to $(gh)^m(e)$ for all $n, m > 0$. \square

Using the above observation we are able to deduce the following obvious consequence.

Lemma 3.39. *Let \mathbb{B} be a minimal finite graph of groups and let $U \leq \pi_1(\mathbb{B}, u_0)$ be a subgroup of finite index and $T_U \leq \widetilde{(\mathbb{B}, u_0)}$ a minimal U -invariant subtree of the associated Bass-Serre tree $\widetilde{(\mathbb{B}, u_0)}$. Then it follows that $T_U = \widetilde{(\mathbb{B}, u_0)}$.*

Proof: Let \mathbb{B} be a minimal graph of groups and let T_U be the unique U -invariant subtree of $T = \widetilde{(\mathbb{B}, u_0)}$ for some finite index subgroup U of $G = \pi_1(\mathbb{B}, u_0)$. If G acts elliptic the statement is trivial. So we may assume that $G = \pi_1(\mathbb{B}, u_0)$ contains some hyperbolic element, say h . As $|G : U| = n \in \mathbb{N}$ it follows that $h^{n!} \in U$. Moreover $h^{n!}$ is hyperbolic and $\text{Axis}(h) = \text{Axis}(h^{n!})$. Thus $\text{Axis}(h) \subseteq T_U$ for any hyperbolic element $h \in G$. Now that claim is a direct consequence of Remark 3.38.2, since \mathbb{B} was supposed to be a minimal graph of groups. \square

We get the following corollary:

Corollary 3.40. *Let \mathbb{B} be a minimal graph of groups and $\mathfrak{f} : \mathbb{A} \rightarrow \mathbb{B}$ be a morphism representing the finite index subgroup $U := \varphi_{\mathfrak{f}}(\pi_1(\mathbb{A}, v_0))$ of $\pi_1(\mathbb{B}, u_0)$. Then it follows that $T := \mathfrak{f}_{\#}(\widetilde{(\mathbb{A}, v_0)}) = \widetilde{(\mathbb{B}, u_0)}$, since U acts on T by Theorem 3.30. In particular any folded morphism representing a subgroup of finite index is already a cover.* \square

3.3.4 Graphs of groups covers and finite index subgroups

We have already seen that for any subgroup U of $\pi_1(\mathbb{B}, u_0)$, there exists a covering representing U . The next step is, to explain how to read off the index of a subgroup by the covering representing it.

The following Theorem will show how it is possible to find a right transversal of the subgroup represented by a covering of graphs of groups.

Theorem 3.41. *Let $f : \mathbb{A} \rightarrow \mathbb{B}$ be a covering of graphs of groups and let $v_0 \in VA$. Furthermore let $u_0 := f(v_0)$, $W := f^{(-1)}(u_0) \subseteq VA$ and $Y \subseteq A$ a maximal subtree of A . For any $w \in W$ let*

- $\gamma_w := f_1^w, \dots, f_{k_w}^w$, $k_w \in \mathbb{N}$, be the unique reduced path from v_0 to w in Y ,
- $p_w := 1_{A_{v_0}}, f_1^w, \dots, f_{k_w}^w, 1_{A_w}$ be the \mathbb{A} -path corresponding to γ_w with the trivial elements in the corresponding vertex groups,
- R_w be a right transversal of $f_w(A_w)$ in $B_{f(w)} = B_{u_0}$,
- $Q_w := \{\mu(p_w) \cdot r \mid r \in R_w\} \subseteq \Sigma_{u_0}^w(\mathbb{B})$.

Furthermore let $Q' := \bigcup_{w \in W} Q_w$. Then the set $Q := \{[q] \mid q \in Q'\}$ forms a right transversal from $\varphi_f(\pi_1(\mathbb{A}, v_0))$ in $\pi_1(\mathbb{B}, u_0)$.

Proof: We show at first $\pi_1(\mathbb{B}, u_0) = \varphi_f(\pi_1(\mathbb{A}, v_0)) \cdot Q$:

” \supseteq ”: trivial, since $\varphi_f(\pi_1(\mathbb{A}, v_0)), Q \subseteq \pi_1(\mathbb{B}, u_0)$.

” \subseteq ”: Let $[q] \in \pi_1(\mathbb{B}, u_0)$. Since $(\widetilde{\mathbb{A}}, v_0) \cong (\widetilde{\mathbb{B}}, u_0)$ there exists an \mathbb{A} -path $[p]$ from v_0 to $w \in W$, s.t.

$$f_f([p]A_w) = [\mu(p)]B_{u_0} = [q]B_{u_0}$$

in $(\widetilde{\mathbb{B}}, u_0)$. Hence there exists $b \in B_{u_0}$ with $[\mu(p) \cdot b] = [q]$. Therefore we find $r \in R_w$ and $a \in A_w$ with $b = f_w(a) \cdot r$, since R_w is a right transversal of $f_w(A_w)$ in $B_{f_{u_0}}$. It follows:

$$\begin{aligned} [q] &= [\mu(p) \cdot b] = [\mu(p) \cdot f_w(a) \cdot r] = [\mu(p) \cdot f_w(a) \cdot \mu(\mathbf{p}_w^{-1} \cdot \mathbf{p}_w) \cdot r] \\ &= [\mu(\mathbf{p} \cdot a \cdot \mathbf{p}_w^{-1}) \cdot \mu(p_w) \cdot r] \\ &= [\mu(p \cdot a \cdot p_w^{-1})] \cdot [\mu(p_w) \cdot r] \in (\pi_1(\mathbb{A}, v_0)) \cdot Q \end{aligned}$$

To complete the proof, it's left to show that for $[q], [q'] \in Q$ we have:

$$\varphi_f(\pi_1(\mathbb{A}, v_0)) \cdot [q] \cap \varphi_f(\pi_1(\mathbb{A}, v_0)) \cdot [q'] \neq \emptyset \Leftrightarrow [q] = [q']. \quad (1)$$

” \Leftarrow ”: trivial

” \Rightarrow ”: So let $\varphi_f([p]), \varphi_f([p']) \in \varphi_f(\pi_1(\mathbb{A}, v_0))$ and

$$[q] := [\mu(p_w) \cdot r], [q'] := [\mu(p_{w'}) \cdot r'] \in Q$$

s.t.

$$\varphi_f([p]) \cdot [\mu(p_w) \cdot r] = \varphi_f([p']) \cdot [\mu(p_{w'}) \cdot r']$$

We obtain:

$$[\mu(p \cdot p_w) \cdot r] = [\mu(p' \cdot p_{w'}) \cdot r'] \quad (2)$$

And again it follows in $(\widetilde{\mathbb{B}}, u_0) \cong (\widetilde{\mathbb{A}}, v_0)$:

$$\begin{aligned} [\mu(p \cdot p_w) \cdot r]B_{u_0} &= [\mu(p \cdot p_w)] \cdot r \cdot B_{u_0} \\ &= [\mu(p \cdot p_w)]B_{u_0} = [\mu(p' \cdot p_{w'})]B_{u_0} \\ &= [\mu(p' \cdot p_{w'})] \cdot r' \cdot B_{u_0} = [\mu(p' \cdot p_{w'}) \cdot r']B_{u_0}. \end{aligned}$$

Thus

$$[p \cdot p_w]A_w = [p' \cdot p_{w'}]A_{w'} \quad (3)$$

And therefore $w = w'$.

So assume $r \neq r'$. Then by (3) there exists $a \in A_w = A_{w'}$, s.t.

$$[p \cdot p_w \cdot a] = [p' \cdot p_{w'}]$$

and by (2) it follows

$$[\mu(p \cdot p_w) \cdot r] = [\mu(p \cdot p_{w'}) \cdot r'] = [\mu(p \cdot p_w \cdot a) \cdot r'] = [\mu(p \cdot p_w) \cdot f_w(a) \cdot r'].$$

and therefore $f_w(a) \cdot r = r'$. This is a contradiction, since $r, r' \in R_w = R_{w'}$ and R_w was supposed to be a right transversal of $f_w(A_w)$ in B_{u_0} .

Hence $r = r'$ and therefore $[\mu(p_w) \cdot r] = [\mu(p_{w'}) \cdot r'] \in Q$ which implies (1). We conclude that Q contains exactly one element of any right coset, proving the claim. \square

Now we are able to count the index of any subgroup $U \leq \pi_1(\mathbb{B}, u_0)$ by means of some cover representing U :

Theorem 3.42. *Let $\mathfrak{f} : \mathbb{A} \rightarrow \mathbb{B}$ be a covering of graphs of groups and $v_0 \in VA$.*

1. *Let $u_0 := f(v_0)$ and $W := f^{(-1)}(u_0) \subseteq VA$. Then it follows that*

$$|\pi_1(\mathbb{B}, f(v_0)) : \varphi_{\mathfrak{f}}(\pi_1(\mathbb{A}, v_0))| = \sum_{w \in W} |B_{u_0} : f_w(A_w)|.$$

2. *For any $v \in VA$, we have*

$$|\pi_1(\mathbb{B}, f(v_0)) : \varphi_{\mathfrak{f}}(\pi_1(\mathbb{A}, v_0))| = |\pi_1(\mathbb{B}, f(v)) : \varphi_{\mathfrak{f}}(\pi_1(\mathbb{A}, v))|.$$

3. *For any $u \in VB$ we have*

$$\sum_{w \in W} |B_{u_0} : f_w(A_w)| = \sum_{z \in f^{-1}(u)} |B_u : f_z(A_z)|.$$

Proof: Let R_w, Q_w, Q' and Q defined as in Theorem 3.41.

1.: So let Q be a right transversal of $\varphi_{\mathfrak{f}}(\pi_1(\mathbb{A}, v_0))$ in $\pi_1(\mathbb{B}, u_0)$. Hence

$$|Q| = |\pi_1(\mathbb{B}, f(v_0)) : \varphi_f(\pi_1(\mathbb{A}, v_0))|.$$

To count the number of different equivalence-classes of \mathbb{B} -paths in Q , we will show at first $|Q| = |Q'|$. That means that pairwise different elements of Q' represent pairwise different equivalence-classes of \mathbb{B} -paths in Q . This is equivalent to that fact, that two elements $q, q' \in Q'$ lie in the same equivalence-class if and only if $q = q'$.

So let $q, q' \in Q'$. Clearly if $q = q'$, we have $[q] = [q']$.

So let $[q] = [q']$. Then there exists $w, w' \in W, r \in R_w, r' \in R_{w'}$, s.t. $q = \mu(p_w) \cdot r$ and $q' = \mu(p_{w'}) \cdot r'$. Hence we obtain

$$[\mu(p_w) \cdot r] = [p] = [p'] = [\mu(p_{w'}) \cdot r'].$$

It follows in the Bass-Serre tree $(\widetilde{\mathbb{B}}, u_0)$

$$[\mu(p_w)]B_{u_0} = [\mu(p_w) \cdot r]B_{u_0} = [\mu(p_{w'}) \cdot r']B_{u_0} = [\mu(p_{w'})]B_{u_0}.$$

As $(\widetilde{\mathbb{A}}, v_0) \cong (\widetilde{\mathbb{B}}, u_0)$, we get

$$[p_w]A_w = [p_{w'}]A_{w'}$$

and therefore $w = w'$.

Since obviously $[\mu(p_w) \cdot r] \neq [\mu(p_w) \cdot r']$ for $r \neq r'$, we deduce $r = r'$.

This means, that two pairwise different \mathbb{B} -paths in Q_w for some $w \in W$ represent two pairwise different equivalence-classes.

So we conclude that $q = q'$.

And therefore it follows that Q' is the disjoint union of the sets Q_w , for $w \in W$, and we have $|Q_w| = |R_w|$.

This implicates

$$|Q| = |Q'| = \sum_{w \in W} |Q_w| = \sum_{w \in W} |R_w| = \sum_{w \in W} |B_{f(u_0)} : f_w(A_w)|.$$

2.: Let $u \in VB$ and $v \in VA$ satisfying $f(v) = u$. Consider some equivalence class of \mathbb{A} -paths $[p_{v_0, v}]$ such that $p_{v_0, v}$ connects v_0 with v . By Lemma 3.16 it follows that the following two maps are isomorphisms:

$$\Phi : \pi_1(\mathbb{A}, v_0) \rightarrow \pi_1(\mathbb{A}, v); [p] \mapsto [p_{v_0, v}^{-1}] \cdot [p] \cdot [p_{v_0, v}],$$

$$\Phi_\mu : \pi_1(\mathbb{B}, u_0) \rightarrow \pi_1(\mathbb{B}, u); [q] \mapsto [\mu(p_{v_0, v}^{-1})] \cdot [q] \cdot [\mu(p_{v_0, v})].$$

Since Q is a right transversal of $\varphi_f(\pi_1(\mathbb{A}, v_0))$ in $\pi_1(\mathbb{B}, u_0)$ we deduce that:

$$\begin{aligned} \pi_1(\mathbb{B}, u) &= [\mu(p_{v_0, v}^{-1})] \cdot \pi_1(\mathbb{B}, u_0) \cdot [\mu(p_{v_0, v})] \\ &= [\mu(p_{v_0, v}^{-1})] \cdot \left(\varphi_f(\pi_1(\mathbb{A}, v_0)) \cdot Q \right) \cdot [\mu(p_{v_0, v})] \end{aligned}$$

$$\begin{aligned}
&= [\mu(p_{v_0,v}^{-1})] \cdot \varphi_{\mathfrak{f}}(\pi_1(\mathbb{A}, v_0)) \cdot [\mu(\mathbf{p}_{v_0,v})][\mu(\mathbf{p}_{v_0,v}^{-1})] \cdot Q \cdot [\mu(p_{v_0,v})] \\
&= \varphi_{\mathfrak{f}}\left([p_{v_0,v}^{-1}]\pi_1(\mathbb{A}, v_0)[p_{v_0,v}]\right) \cdot [\mu(p_{v_0,v}^{-1})] \cdot Q \cdot [\mu(p_{v_0,v})] \\
&\stackrel{\Phi \text{ Isom.}}{=} \varphi_{\mathfrak{f}}(\pi_1(\mathbb{A}, v)) \cdot [\mu(p_{v_0,v}^{-1})]Q[\mu(p_{v_0,v})].
\end{aligned}$$

As Φ_μ is an isomorphism, it follows that $Q^v := [\mu(p_{v_0,v}^{-1})]Q[\mu(p_{v_0,v})]$ is a right transversal of $\varphi_{\mathfrak{f}}(\pi_1(\mathbb{A}, v))$ in $\pi_1(\mathbb{B}, u)$ s.t. $|Q^v| = |Q|$. Hence it follows **2.**

3.: **1.** implies for v instead of v_0 :

$$|Q^v| = |\pi_1(\mathbb{B}, u) : \varphi_{\mathfrak{f}}(\pi_1(\mathbb{A}, v))| = \sum_{z \in f^{-1}(u)} |B_u : f_z(A_z)|.$$

And we conclude

$$\sum_{w \in W} |B_{u_0} : f_w(A_w)| = |Q| = |Q^v| = \sum_{z \in f^{-1}(u)} |B_{f(u)} : f_z(A_z)|.$$

□

Clearly the index of a subgroup represented by a cover $\mathfrak{f} : \mathbb{A} \rightarrow \mathbb{B}$ does not have to be finite, since we can associate to any subgroup $U \leq \pi_1(\mathbb{B}, u_0)$ a cover. But if \mathbb{B} is a graph of groups, s.t. the underlying graph B of \mathbb{B} is finite, the following corollary provides a criterion for deciding, whether the represented subgroup $U \leq \pi_1(\mathbb{B}, u_0)$ is of finite index or not.

Corollary and Definition 3.43. *Let \mathbb{B} be graph of groups and $U \leq \pi_1(\mathbb{B}, u_0) =: G$. Furthermore let B be a finite graph. Then U is of finite index in G if and only if there exists a **finite-sheeted** cover of graphs of groups $\mathfrak{f} : \mathbb{A} \rightarrow \mathbb{B}$ representing U , i.e.*

1. $\varphi_{\mathfrak{f}}(\pi_1(\mathbb{A}, v_0)) = U$ for some $v_0 \in VA$;
2. The underlying graph A of \mathbb{A} is finite;
3. $|B_{f(v)} : f_v(A_v)| < \infty$ f.a. $v \in VA$.

Proof:

" \Leftarrow ": Let $\mathfrak{f} : \mathbb{A} \rightarrow \mathbb{B}$ satisfying the mentioned properties. Since A is finite, it follows that $|f^{-1}(u_0)| \leq |VA| < \infty$ and hence by 3. and Theorem 3.42 the claim follows.

" \Rightarrow ": Let $|\pi_1(\mathbb{B}, u_0) : U| < \infty$. Then by Theorem 3.35 there exists a covering $\mathfrak{f} : \mathbb{A} \rightarrow \mathbb{B}$ representing U satisfying the first condition.

Assume that A is an infinite graph or that there exists $v \in VA$ s.t. $|f_v(A_v) : B_{f(v)}| = \infty$. In the first case there exists $u \in VB$ with $|f^{-1}(u)| = \infty$ and in the second there exists $u \in VB$ with $f(v) = u$. In both cases we conclude

$$\infty > |\pi_1(\mathbb{B}, u_0) : \varphi_{\mathfrak{f}}(\pi_1(\mathbb{A}, v_0))| \stackrel{3.42}{=} \sum_{v \in f^{-1}(u)} |B_{f(v)} : f_v(A_v)| = \infty.$$

This contradicts the assumption. Thus we are done. □

We close this chapter with the following remark.

Remark 3.44. Let $\mathfrak{f} : \mathbb{A} \rightarrow \mathbb{B}$ be a cover of graphs of groups, s.t. the underlying graph B of \mathbb{B} is finite. Clearly we can apply Corollary 3.43 to $U := \varphi_{\mathfrak{f}}(\pi_1(\mathbb{A}, v_0))$. That means, for any cover \mathfrak{f} we can easily verify, whether the represented subgroup $\varphi_{\mathfrak{f}}(\pi_1(\mathbb{A}, v_0)) \leq \pi_1(\mathbb{B}, u_0)$ is of finite index or not. And if this index is finite, Theorem 3.42 allows us to compute this natural number.

3.4 Auxiliary modifications and Decktransformations of graph of group morphisms

Recall that a morphism $f : \tilde{\Gamma} \rightarrow \Gamma$ of ordinary graphs $\tilde{\Gamma}$ and Γ is called a cover, if f is surjective and locally injective. Furthermore for any cover of graphs $f : \tilde{\Gamma} \rightarrow \Gamma$ the group of Decktrasformations of f , which is defined as

$$\text{Deck}(f) = \{\alpha \mid \alpha \text{ automorphism of } \tilde{\Gamma} \text{ with } f \circ \alpha = f\}$$

is isomorphic to the group $N_G(U)/U$ if $G = \pi_1(\Gamma, u_0)$ and $U = \varphi_f(\pi_1(\tilde{\Gamma}, \tilde{u}_0))$ for some $u_0 \in V\Gamma$ and $\tilde{u}_0 \in V\tilde{\Gamma}$ with $f(\tilde{u}_0) = u_0$. Following [44] Theorem 2.28 the isomorphism is given by

$$\chi : \text{Deck}(f) \rightarrow N_G(U)/U, \alpha \mapsto [f(\tilde{\gamma}_\alpha)]U$$

if $f(\tilde{\gamma}_\alpha)$ is the image of a path $\tilde{\gamma}_\alpha$ connecting \tilde{u}_0 with $\alpha(\tilde{u}_0)$.

In this chapter we give a reasonable definition of the group of Decktransformations for a cover of graphs of groups $\mathfrak{f} : \mathbb{A} \rightarrow \mathbb{B}$ representing some subgroup $U \leq G := \pi_1(\mathbb{B}, u_0)$, $u_0 \in VB$, and we will prove a similar correspondence between the normalizer $N_G(U)$ of U in G and the group of Decktransformations. In particular we will prove that the group of Decktransformations of \mathfrak{f} is isomorphic to the group $N_G(U)/ZU$ if Z is the intersection of the centralizer $Z_G(U)$ of U in G and the kernel K of the action of G on $(\widetilde{\mathbb{B}}, u_0)$.

3.4.1 Auxiliary Modifications of morphisms of graphs of groups

Let $\mathfrak{f} : \mathbb{A} \rightarrow \mathbb{B}$ be a morphism. Clearly the maps $\varphi_{\mathfrak{f}}$ and $f_{\mathfrak{f}}$ depend on the choice of a base point $v_0 \in VA$. In contrast to the previous chapters, where it was most of the time negligible which base point was chosen, it is now necessary to determine for which base point we consider the maps $\varphi_{\mathfrak{f}}$ and $f_{\mathfrak{f}}$. Therefore we define for some chosen $v_0 \in VA$ $\varphi_{\mathfrak{f}}^{v_0}$ and $f_{\mathfrak{f}}^{v_0}$ to be the maps on group and tree level corresponding to the chosen base point v_0 . Note that in the last chapters we often omit the subscript \mathfrak{f} in $\mu_{\mathfrak{f}}$ and write μ instead of $\mu_{\mathfrak{f}}$ for the associated map on \mathbb{A} -path level. In this chapter we will often make use of this notation to point out which map on \mathbb{A} -path level is used in the context and we will still omit this subscript if it is obvious which map on \mathbb{A} -path level is used.

In the following we will often modify a graph of group morphism in an inessential way:

Lemma and Definition 3.45. Let $\mathfrak{f} : \mathbb{A} \rightarrow \mathbb{B}$ be a graph of group morphism and $v_0 \in VA$. Then the following hold:

1. Let \mathfrak{f}' obtained from \mathfrak{f} by replacing g_e^α by $g_e^\alpha \alpha_{f(e)}(b)$, g_e^ω by $\omega_{f(e)}(b^{-1})g_e^\omega$ and f_e by $c_{b^{-1}} \circ f_e : A_e \rightarrow B_{f(e)}, a \mapsto b^{-1} \cdot f_e(a) \cdot b$ for some $e \in EA$ and $b \in B_{f(e)}$. Then $\varphi_{\mathfrak{f}} = \varphi_{\mathfrak{f}'}$ and $f_{\mathfrak{f}} = f_{\mathfrak{f}'}$. We call this an **auxiliary modification** of the first type.

2. If \mathfrak{f}' is obtained from \mathfrak{f} by replacing g_e^α by $g \cdot g_e^\alpha$ for some $g \in A_{\alpha(e)}$ then \mathfrak{f} and \mathfrak{f}' differ by precomposition by a graph of group automorphism.
3. Replace f_v by $c_b \circ f_v : A_v \rightarrow B_{f(v)}$, $a \mapsto b \cdot f_v(a) \cdot b^{-1}$ and g_e^α by $b \cdot g_e^\alpha$ for some $b \in B_{f(v)}$ and all e with $\alpha(e) = v$. We call this an **auxiliary modification** of the second type. If v is not the base vertex it follows that $\varphi_{\mathfrak{f}} = \varphi_{\mathfrak{f}'}$ and $f_{\mathfrak{f}} = f_{\mathfrak{f}'}$, otherwise they differ by postcomposition with a graph of group automorphism, in fact by conjugation.

Proof: The first assertion is immediate, the same is true for the third claim if v is distinct from the base vertex. If v is the base vertex then it is easily verified that $f_{\mathfrak{f}'}(x) = [b] \cdot f_{\mathfrak{f}}(x)$ for all $x \in \widetilde{(\mathbb{A}, v)}$ and $\varphi_{\mathfrak{f}'}(g) = [b] \cdot \varphi_{\mathfrak{f}}(g) \cdot [b]^{-1}$ for all $g \in \pi_1(\mathbb{A}, v)$ which proves the claim.

The second assertion holds as $\mathfrak{f}' = \mathfrak{f} \circ \mathfrak{h}$ where $\mathfrak{h} : \mathbb{A} \rightarrow \mathbb{A}$ is the graph of group automorphism

$$\mathfrak{h} = (h, \{h_v | v \in VA\}, \{h_e | e \in EA\}, \{\bar{g}_e^\alpha | e \in EA\}, \{\bar{g}_e^\omega | e \in EA\})$$

where $h = id_A$, $h_v = id_{A_v}$ for all $v \in VA$, $h_e = id_{A_e}$ for all $e \in EA$, $\bar{g}_f^\alpha = 1$ for $f \neq e$ and $g_e^\alpha = g$. \square

Lemma 3.46. *Let $\mathfrak{f} : \mathbb{A} \rightarrow \mathbb{B}$ and $\mathfrak{f}' : \mathbb{A} \rightarrow \mathbb{B}$ be morphisms and $v_0 \in VA$. Then $\varphi_{\mathfrak{f}}^{v_0} = \varphi_{\mathfrak{f}'}^{v_0}$ and $f_{\mathfrak{f}}^{v_0} = f_{\mathfrak{f}'}^{v_0}$ if and only if \mathfrak{f}' can be obtained from \mathfrak{f} by auxiliary modifications of the first type and auxiliary modifications of the second type in $v \in VA \setminus \{v_0\}$.*

Proof: As shown before, auxiliary modifications of the first type and of the second type in $v \in VA \setminus \{v_0\}$ doesn't change the maps $\varphi_{\mathfrak{f}}^{v_0}$ and $f_{\mathfrak{f}}^{v_0}$. So let $\varphi_{\mathfrak{f}}^{v_0} = \varphi_{\mathfrak{f}'}^{v_0}$ and $f_{\mathfrak{f}} = f_{\mathfrak{f}'}$. Clearly the assumptions imply $f = f'$. Let A' be a maximal subgraph of A with $v_0 \in VA'$, such that for the induced subgraph of groups \mathbb{A}' the two restrictions $\mathfrak{f}|_{\mathbb{A}'}$ and $\mathfrak{f}'|_{\mathbb{A}'}$ only differ by auxiliary modifications. Clearly $\mathbb{A}' \neq \emptyset$ since obviously $f_{v_0} = f'_{v_0}$ and if $\mathbb{A}' = \mathbb{A}$ there is nothing to prove. So assume $\mathbb{A}' \neq \mathbb{A}$. Let $e \in EA \setminus EA'$ such that $\alpha(e) = v \in VA'$ and $\omega(e) = v'$. Let $p = 1_{A_{v_0}}, e_1, \dots, e_m, 1_{A_v}$ be an \mathbb{A}' -path connecting v_0 with v with trivial elements in the corresponding vertex groups. Since $\mathfrak{f}|_{\mathbb{A}'}$ and $\mathfrak{f}'|_{\mathbb{A}'}$ only differ by auxiliary modifications we can assume that $f_v = f'_v$ and $g_{e_i}^\alpha = (g_{e_i}^\alpha)'$, $g_{e_i}^\omega = (g_{e_i}^\omega)'$ for any $i \in \{1, \dots, m\}$. If now $\mu := \mu_{\mathfrak{f}}$ and $\mu' := \mu_{\mathfrak{f}'}$ it follows that $\mu(p) = \mu'(p)$ as $f = f'$ and $f_{\mathfrak{f}} = f_{\mathfrak{f}'}$ imply

$$[\mu(p)] \cdot [g_e^\alpha, f(e), g_e^\omega] \cdot B_{v'} = [\mu'(p)] \cdot [(g_e^\alpha)', f'(e), (g_e^\omega)'] \cdot B_{v'}.$$

Thus

$$\mu(p) \cdot g_e^\alpha, f(e), g_e^\omega \sim \mu'(p) \cdot (g_e^\alpha)', f'(e), (g_e^\omega)' \cdot b$$

for some $b \in B_{v'}$. If $f(e) = f'(e) := l$ it follows that

$$\mu'(p) \cdot g_e^\alpha, l, g_e^\omega \sim \mu'(p) \cdot (g_e^\alpha)', l, (g_e^\omega)' \cdot b$$

implying that $g_e^\alpha, l, g_e^\omega \sim (g_e^\alpha)', l, (g_e^\omega)' \cdot b$. Hence there exists $c \in B_{f(e)}$ such that

$$g_e^\alpha \cdot \alpha_l(c), l, \omega_l(c^{-1}) \cdot g_e^\omega = (g_e^\alpha)', l, (g_e^\omega)' \cdot b.$$

After performing an auxiliary modification of the first type, we can assume that

$$g_e^\alpha, l, g_e^\omega = (g_e^\alpha)', l, (g_e^\omega)' \cdot b$$

implying $g_e^\alpha = (g_e^\alpha)'$ and $g_e^\omega = (g_e^\omega)' \cdot b$. Now since $\varphi_f = \varphi_{f'}$ it follows for $q = p \cdot 1_{A_v}, e, 1_{A_{v'}}$ that

$$\mu'(q) \cdot f'_{v'}(a) \cdot \mu'(q^{-1}) \sim \mu(q) \cdot f_{v'}(a) \cdot \mu(q^{-1}) = \mu'(q) \cdot b \cdot f_{v'}(a) \cdot b^{-1} \cdot \mu'(q^{-1}).$$

As $\mu(p) = \mu'(p)$ and $g_e^\alpha = (g_e^\alpha)'$ we deduce that

$$(g_e^\omega)' \cdot f'_{v'}(a) ((g_e^\omega)')^{-1} = g_e^\omega f_{v'}(a) (g_e^\omega)^{-1} = (g_e^\omega)' \cdot b \cdot f_{v'}(a) \cdot b^{-1} \cdot ((g_e^\omega)')^{-1}$$

for any $a \in A_{v'}$ implying that $b \cdot f_{v'}(a) \cdot b^{-1} = f'_{v'}(a)$ for any $a \in A_{v'}$. We distinguish two cases:

Case 1: Let $v' \notin A'$. Then replacing $f_{v'}$ by $c_b \circ f_{v'} : A_{v'} \rightarrow B_{f(v')}$, $a \mapsto b \cdot f_{v'}(a) \cdot b^{-1}$ and $g_{e'}^\alpha$ by $b \cdot g_{e'}^\alpha$ for any $e' \in EA$ with $\alpha(e') = v'$ makes sure that $g_{e-1}^\alpha = (g_e^\omega)^{-1}$ is replaced by $b \cdot g_{e-1}^\alpha = b \cdot (g_e^\omega)^{-1} = (g_e^\omega \cdot b^{-1})^{-1} = ((g_e^\omega)')^{-1}$. Note that now $f_{v'} = f'_{v'}$.

Case 2: Assume that $v' \in A'$. After performing some suitable auxiliary modification we may assume that $f_{v'} = f'_{v'}$. Thus

$$b \in C_{B_{f(v')}}(f_{v'}(A_{v'})) = \{c \in B_{f(v')} \mid ca = ac \text{ f.a. } a \in f_{v'}(A_{v'})\}.$$

Thus $c_b \circ f_{v'} = f'_{v'} = f_{v'}$. Thus we only replace $g_{e-1}^\alpha = (g_e^\omega)^{-1}$ by $b \cdot g_{e-1}^\alpha = b \cdot (g_e^\omega)^{-1} = (g_e^\omega \cdot b^{-1})^{-1} = ((g_e^\omega)')^{-1}$.

In both cases we have that

$$g_e^\alpha \cdot \alpha_l(f_e(c)) \cdot (g_e^\alpha)^{-1} = f_v(\alpha_e(c)) = f'_v(\alpha_e(c)) = (g_e^\alpha)' \cdot \alpha_l(f'_e(c)) \cdot ((g_e^\alpha)')^{-1}$$

with $f(e) = l = f'(e)$ for any $c \in A_e$ implying that $\alpha_l(f_e(c)) = \alpha_l(f'_e(c))$ for any $c \in A_e$ since $g_e^\alpha = (g_e^\alpha)'$. Thus $f_e = f'_e$ and we conclude that the subgraph of groups \mathbb{A}'' induced by defining $VA'' := VA \cup \{v'\}$ and $EA'' := EA \cup \{e\} \neq EA'$ satisfies that $\mathfrak{f}|_{\mathbb{A}''}$ and $\mathfrak{f}'|_{\mathbb{A}''}$ differ only by auxiliary modifications. A contradiction to the maximality of A' . Hence we are done. \square

The following statement is now immediate.

Lemma and Definition 3.47. *Let $\mathfrak{f} : \mathbb{A} \rightarrow \mathbb{B}$ and $\mathfrak{f}' : \mathbb{A} \rightarrow \mathbb{B}$ be morphisms and $V \subseteq VA$. We call \mathfrak{f} and \mathfrak{f}' V -congruent and write $\mathfrak{f} \stackrel{V}{\equiv} \mathfrak{f}'$ if \mathfrak{f}' can be obtained from \mathfrak{f} by auxiliary modifications of the first type and auxiliary modifications of the second type in $v \in VA \setminus V$. We denote the equivalence class of \mathfrak{f} by $[\mathfrak{f}]_{\stackrel{V}{\equiv}}$. Clearly $\varphi_{\mathfrak{f}}^{v_0} = \varphi_{\mathfrak{f}'}^{v_0}$ and $f_{\mathfrak{f}}^{v_0} = f_{\mathfrak{f}'}^{v_0}$ if $v_0 \in V$. Then $\stackrel{V}{\equiv}$ defines a equivalence relation on the set of morphisms $\mathfrak{f} : \mathbb{A} \rightarrow \mathbb{B}$. If $V = \emptyset$ then we simply write $\mathfrak{f} \equiv \mathfrak{f}'$. Moreover if $V = \{v\}$ for some $v \in VA$ we write $\stackrel{v}{\equiv}$ instead of $\stackrel{\{v\}}{\equiv}$. \square*

The following Remarks are easy to check:

Remark 3.48. *Let $\mathfrak{f} : \mathbb{A} \rightarrow \mathbb{B}$ and $\mathfrak{f}' : \mathbb{A} \rightarrow \mathbb{B}$ be morphisms. And let $V' \subseteq V \subseteq VB$. Then $\mathfrak{f} \stackrel{V}{\equiv} \mathfrak{f}'$ implies $\mathfrak{f} \stackrel{V'}{\equiv} \mathfrak{f}'$. Thus $\stackrel{V'}{\equiv}$ is an refinement of the equivalence relation $\stackrel{V}{\equiv}$. In particular $\stackrel{V}{\equiv}$ is an refinement of \equiv and it follows $\mathfrak{f} \stackrel{VB}{\equiv} \mathfrak{f}'$ if and only if $\mathfrak{f} = \mathfrak{f}'$. \square*

Remark 3.49. Let $f_i : \mathbb{A} \rightarrow \mathbb{B}$ and $h_i : \mathbb{B} \rightarrow \mathbb{C}$, $i \in \{1, 2\}$ morphisms and $V \subseteq VA$ such that $f_1 \stackrel{V}{\equiv} f_2$. Note that this implies $f_1(v) = f_2(v)$ f.a. $v \in VA$. Assume that $h_1 \stackrel{f_1(V)}{\equiv} h_2$. Clearly $h_i \circ f_i : \mathbb{A} \rightarrow \mathbb{C}$ are morphisms and it follows $h_1 \circ f_1 \stackrel{V}{\equiv} h_2 \circ f_2$ implying that the given equivalence relation is compatible with the multiplication of morphisms of graphs of groups. \square

We close this section with the following important observation.

Lemma 3.50. Let $f, f' : \mathbb{A} \rightarrow \mathbb{B}$ be a morphisms with $f \equiv f'$. Then for any $v \in VA$ there exists some $b_v \in B_{f(v)}$ such that the following properties are satisfied.

1. $[b_{v_1} \mu_f(p) b_{v_2}^{-1}] = [\mu_{f'}(p)]$ for any $p \in \Sigma_{v_1}^{v_2}$.

For any chosen base point $v_0 \in VA$:

2. $[b_{v_0}] \varphi_f^{v_0}([p]) [b_{v_0}]^{-1} = \varphi_{f'}^{v_0}([p])$ for any $[p] \in \pi_1(\mathbb{A}, v_0)$.

3. $f_{\bar{f}}^{v_0}([p] A_{\omega(p)}) = [b_{v_0}] f_{\bar{f}'}^{v_0}([p] A_{\omega(p)})$ for any $p \in \Sigma_{v_0}^{\omega(p)}$.

Proof: First observe that it suffices to show the first assertion since the second and the third statement are immediate consequences of the first. Since $f \equiv f'$ it follows $f(x) = f'(x)$ for any $x \in VA \cup EA$ and there exists for any $v \in VA$ some $b_v \in B_{f(v)}$ and for any $e \in EA$ some $c \in B_{f(e)}$ such that for any $e \in EA$ with $\alpha(e) = v_1$ and $\omega(e) = v_2$ it follows that

1. $(g_e^\alpha)' = b_{v_1} g_e^\alpha \alpha_{f(e)}(c)$,
2. $(g_e^\omega)' = \omega_{f(e)}(c) g_e^\omega b_{v_2}^{-1}$,
3. $b_{v_i} f_{v_i}(a) b_{v_i}^{-1} = f'_{v_i}$ for $i \in \{1, 2\}$.

If now $p = a_0, e_1, \dots, e_k, a_k$ is an \mathbb{A} -path for some $k \in \mathbb{N}$ it follows by definition of μ_f and $\mu_{f'}$ that

$$[\mu_f(p)] = [b_0, f(e_1), b_1, f(e_2), \dots, f(e_k), b_k]$$

where $b_0 = f_{\alpha(e_1)}(a_0) \cdot g_{e_1}^\alpha$, $b_k = g_{e_k}^\omega \cdot f_{\omega(e_k)}(a_k)$ and $b_i = g_{e_i}^\omega \cdot f_{\omega(e_i)}(a_i) \cdot g_{e_{i+1}}^\alpha$ for $1 \leq i \leq k-1$ and

$$[\mu_{f'}(p)] = [b'_0, f'(e_1), b'_1, f'(e_2), \dots, f'(e_k), b'_k]$$

where $b'_0 = f'_{\alpha(e_1)}(a_0) \cdot (g_{e_1}^\alpha)'$, $b'_k = (g_{e_k}^\omega)' \cdot f'_{\omega(e_k)}(a_k)$ and $b'_i = (g_{e_i}^\omega)' \cdot f'_{\omega(e_i)}(a_i) \cdot (g_{e_{i+1}}^\alpha)'$ for $1 \leq i \leq k-1$.

Thus it follows $[b_{v_0} \mu_f(p) b_{v_n}^{-1}] = [\mu_{f'}(p)]$. \square

3.4.2 The group of Decktransformations associated to a cover of graphs of groups

We have now the setup to define the group of Decktransformation associated to some cover $f : \mathbb{A} \rightarrow \mathbb{B}$ in terms of \equiv -equivalence classes. For convenience, we will drop the subscript in the \equiv -equivalence class $[f]_{\equiv}$ associated to some morphism $f : \mathbb{A} \rightarrow \mathbb{B}$ and just write $[f]$ instead of $[f]_{\equiv}$.

Definition 3.51. Let $\mathfrak{f} : \mathbb{A} \rightarrow \mathbb{B}$ be a cover. Then we call the elements

$$\text{Deck}(\mathfrak{f}) = \{[\mathfrak{h}] \mid \mathfrak{h} \text{ is a graph of group automorphism of } \mathbb{A} \text{ s.t. } [\mathfrak{f} \circ \mathfrak{h}] = [\mathfrak{f}]\}$$

Decktransformations of \mathfrak{f} .

The following statement combined with Remark 3.49 implies now that $\text{Deck}(\mathfrak{f})$ admits a group structure, if we define $[\mathfrak{h}_1] \circ [\mathfrak{h}_2] := [\mathfrak{h}_1 \circ \mathfrak{h}_2]$ for any $[\mathfrak{h}_1], [\mathfrak{h}_2] \in \text{Deck}(\mathfrak{f})$ since the equivalence relation \equiv is compatible with the multiplication of graph of group morphisms.

Lemma 3.52. Let $\mathfrak{f} : \mathbb{A}^1 \rightarrow \mathbb{A}^2$ be an isomorphism of graphs of groups. Then there exists a unique graphs of groups isomorphism $\mathfrak{h} : \mathbb{A}^2 \rightarrow \mathbb{A}^1$ such that $\mathfrak{f} \circ \mathfrak{h} = \mathfrak{h} \circ \mathfrak{f} = \text{id}$, where

$$\text{id} := \{\text{id}, \{f_v = \text{id} \mid v \in VA^i\}, \{f_e = \text{id} \mid e \in EA^i\}, \{g_e^\alpha = 1 \mid e \in EA^i\}, \{g_e^\omega = 1 \mid e \in EA^i\}$$

for any $i \in \{1, 2\}$.

Proof: Let $\mathfrak{f} = \{f, \{f_v \mid v \in VA\}, \{f_e \mid e \in EA\}, \{g_e^\alpha \mid e \in EA\}, \{g_e^\omega \mid e \in EA\}\}$. Since \mathfrak{f} is an isomorphism there exists an isomorphism of graphs $f^{-1} : \mathbb{A}^2 \rightarrow \mathbb{A}^1$ and group isomorphisms $f_x^{-1} : A_{f(x)} \rightarrow A_x$ for any $x \in VA^1 \cup EA^1$. Define $\mathfrak{h} = \{h, \{h_{f(v)} \mid v \in VA^1\}, \{h_{f(e)} \mid e \in EA^1\}, \{(g_{f(e)}^\alpha)'\mid e \in EA^1\}, \{(g_{f(e)}^\omega)'\mid e \in EA^1\}$ such that the following holds:

1. $h := f^{-1}$
2. $h_{f(x)} := f_x^{-1}$ for any $x \in VA^1 \cup EA^1$.
3. $((g_{f(e)}^\omega)')^{-1} = (g_{f(e)}^\alpha)' = f_{\alpha(e)}^{-1}((g_e^\alpha)^{-1}) = (f_{\alpha(e)}^{-1}(g_e^\alpha))^{-1}$.

It is easily verified that $\mathfrak{h} : \mathbb{A}^2 \rightarrow \mathbb{A}^1$ is the desired graph of group isomorphism. \square

Note that it is straight forward computation to verify that the following is true:

Corollary 3.53. Let $\mathfrak{f} : \mathbb{A} \rightarrow \mathbb{B}$ be a cover. Then $(\text{Deck}(\mathfrak{f}), \circ)$ is a group. As usual we will identify the group $(\text{Deck}(\mathfrak{f}), \circ)$ with the set $\text{Deck}(\mathfrak{f})$. \square

To establish a group theoretical relation between $\text{Deck}(\mathfrak{f})$ and the normalizer of the represented subgroup of \mathfrak{f} we need the following statements. Applying Lemma 3.50 to some element of $\text{Deck}(\mathfrak{f})$ we receive the following immediate consequences:

Corollary and Definition 3.54. Let $\mathfrak{h} \in [\mathfrak{h}] \in \text{Deck}(\mathfrak{f})$ for some cover $\mathfrak{f} : \mathbb{A} \rightarrow \mathbb{B}$. Let $\mathfrak{f}' := \mathfrak{f} \circ \mathfrak{h}$. Then for any $v \in VA$ there exists some b_v^h such that the following properties are satisfied.

$$(1) [b_{h(v_1)}^h \mu_{\mathfrak{f}}(p) (b_{h(v_2)}^h)^{-1}] = [\mu_{\mathfrak{f}'}(p)] = [\mu_{\mathfrak{f}}(\mu_{\mathfrak{h}}(p))] \text{ for any } p \in \Sigma_{v_1}^{v_2}.$$

For any chosen base point $v_0 \in VA$:

$$(2) [b_{h(v_0)}^h \varphi_{\mathfrak{f}}^{v_0}([p]) (b_{h(v_0)}^h)^{-1}] = \varphi_{\mathfrak{f}}^{h(v_0)}([p]) \text{ for any } [p] \in \pi_1(\mathbb{A}, v_0).$$

$$(3) f_{\mathfrak{f}}^{v_0}([p]A_{\omega(p)}) = [b_{h(v_0)}^h] f_{\mathfrak{f}}^{h(v_0)}([p]A_{\omega(p)}) \text{ for any } p \in \Sigma_{v_0}^{\omega(p)}.$$

(4) For any $b \in B_{u_0}$ define $\mathfrak{f}^b : \mathbb{A} \rightarrow \mathbb{B}$ to be the cover obtained from \mathfrak{f} by performing the auxiliary modification of the second type corresponding to b in v_0 . Then by (2) and (3) it follows $\mathfrak{f} \circ \mathfrak{h} \stackrel{v_0}{\equiv} \mathfrak{f}^{b_{h(v_0)}^h}$. \square

Since our aim is to create an epimorphism $\chi : N_G(U) \rightarrow \text{Deck}(\mathfrak{f})$ for some subgroup U represented by some cover $\mathfrak{f} : \mathbb{A} \rightarrow \mathbb{B}$ we need to observe the following crucial fact.

Lemma 3.55. *Let $[h^1], [h^2] \in \text{Deck}(\mathfrak{f})$ such that $v_i := h^i(v_0)$ and $v_{1,2} = h^1 \circ h^2(v_0)$. Then $\mathfrak{f} \circ \mathfrak{h}^1 \circ \mathfrak{h}^2 \stackrel{v_0}{\cong} \mathfrak{f}^{b_{v_{1,2}}^{h^1} b_{v_2}^{h^2}}$.*

Proof: Let $p \in \Sigma_{v_0}^{v'}$. Then it follows

$$\mu_{\mathfrak{f} \circ \mathfrak{h}^1 \circ \mathfrak{h}^2}(p) = \mu_{\mathfrak{f}}(\mu_{\mathfrak{h}^1}(\mu_{\mathfrak{h}^2}(p))) = b_{v_{1,2}}^{h^1} \mu_{\mathfrak{f}}(\mu_{\mathfrak{h}^2}(p)) (b_{v_{1,2}}^{h^1})^{-1} = b_{v_{1,2}}^{h^1} b_{v_2}^{h^2} \mu_{\mathfrak{f}}(p) (b_{v_2}^{h^2})^{-1} (b_{v_{1,2}}^{h^1})^{-1}$$

for $v'_{1,2} = \omega(\mu_{\mathfrak{h}^1 \circ \mathfrak{h}^2}(p))$ and $v'_2 = \omega(\mu_{\mathfrak{h}^2}(p))$.

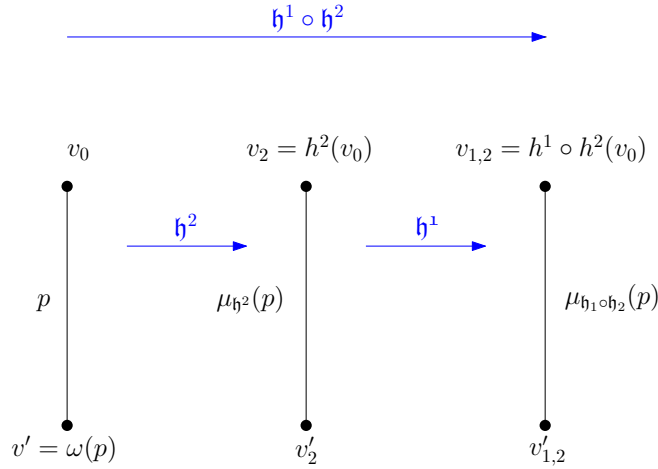

Figure 1: The paths p , $\mu_{h^2}(p)$ and $\mu_{h^1 \circ h^2}(p)$.

Now the claim follows by applying Corollary 3.54. \square

Assume that $\mathfrak{f} : \mathbb{A} \rightarrow \mathbb{B}$ is a cover such that the represented subgroups corresponding to two base points $v_0, v'_0 \in f^{-1}(u_0)$ for some $u_0 \in VB$ are conjugated by some element b of B_{u_0} in $\pi_1(\mathbb{B}, u_0)$. Then the following two statements ensure that we find a unique $[\mathfrak{h}] \in \text{Deck}(\mathfrak{f})$ such that $\mathfrak{f} \circ \mathfrak{h} \stackrel{v_0}{\cong} \mathfrak{f}^b$:

Lemma 3.56. *Let $\mathfrak{f}^1 : \mathbb{A}^1 \rightarrow \mathbb{B}$ and $\mathfrak{f}^2 : \mathbb{A}^2 \rightarrow \mathbb{B}$ be covers of graphs of groups representing the same subgroup U of $\pi_1(\mathbb{B}, u_0)$, i.e. $\varphi_{\mathfrak{f}^i}^{v_0^i}(\pi_1(\mathbb{A}^i, v_0^i)) = U$ for some $v_0^i \in VA^i$, $i \in \{1, 2\}$.*

Then there exists a graph of group isomorphism $\mathfrak{h} : \mathbb{A}^1 \rightarrow \mathbb{A}^2$ such that $\mathfrak{f}^2 \circ \mathfrak{h} \stackrel{v_0^1}{\cong} \mathfrak{f}^1$.

Proof: Clearly $\varphi_{\mathfrak{f}^i}^{v_0^i}$ are isomorphisms of groups and $f_{\mathfrak{f}^i}^{v_0^i}$ are $\varphi_{\mathfrak{f}^i}^{v_0^i}$ -equivariant isomorphisms for $i \in \{1, 2\}$. Thus the pair $(\varphi_{\mathfrak{f}^i}^{v_0^i}, f_{\mathfrak{f}^i}^{v_0^i})$ is an isomorphism from the $\pi_1(\mathbb{A}^i, v_0^i)$ -tree $\widetilde{(\mathbb{A}^i, v_0^i)}$ to the U -tree $\widetilde{(\mathbb{B}, u_0)}$ for $i \in \{1, 2\}$. Now it is easy to check that the pair $((\varphi_{\mathfrak{f}^2}^{v_0^2})^{-1} \circ \varphi_{\mathfrak{f}^1}^{v_0^1}, (f_{\mathfrak{f}^2}^{v_0^2})^{-1} \circ f_{\mathfrak{f}^1}^{v_0^1})$ is a well defined isomorphism from the $\pi_1(\mathbb{A}^1, v_0^1)$ -tree $\widetilde{(\mathbb{A}^1, v_0^1)}$ to the $\pi_1(\mathbb{A}^2, v_0^2)$ -tree $\widetilde{(\mathbb{A}^2, v_0^2)}$. Applying Theorem 3.30 there exists $\mathfrak{h} : \mathbb{A}^1 \rightarrow \mathbb{A}^2$ with $(\varphi_{\mathfrak{h}}^{v_0^1}, f_{\mathfrak{h}}^{v_0^1}) = ((\varphi_{\mathfrak{f}^2}^{v_0^2})^{-1} \circ \varphi_{\mathfrak{f}^1}^{v_0^1}, (f_{\mathfrak{f}^2}^{v_0^2})^{-1} \circ f_{\mathfrak{f}^1}^{v_0^1})$ and therefore $\mathfrak{f}^2 \circ \mathfrak{h} \stackrel{v_0^1}{\cong} \mathfrak{f}^1$ by definition of $\stackrel{v_0^1}{\cong}$. \square

So we deduce the following:

Corollary 3.57. *Let $f : \mathbb{A} \rightarrow \mathbb{B}$ be a cover and let $U = \varphi_f^{v_0}(\pi_1(\mathbb{A}, v_0)) \leq G = \pi_1(\mathbb{B}, u_0)$. Assume that there exists $b \in B_{u_0}$ such that $U = \varphi_f^{v'_0}(\pi_1(\mathbb{A}, v'_0))^b$ for some $v'_0 \in f^{-1}(u_0)$. Then the following holds:*

1. *There exists a graph of groups automorphism $h : \mathbb{A} \rightarrow \mathbb{A}$ satisfying $f \circ h \stackrel{v_0}{\cong} f^b$ and $h(v_0) = v'_0$.*
2. *For any two automorphisms $h^1, h^2 : \mathbb{A} \rightarrow \mathbb{A}$ satisfying $f \circ h^i \stackrel{v_0}{\cong} f^b$ and $h^i(v_0) = v'_0$ for $i \in \{1, 2\}$, it follows $h^1 \stackrel{v_0}{\cong} h^2$.*

Proof:

1. Assume that $U^{b^{-1}} = \varphi_f^{v'_0}(\pi_1(\mathbb{A}, v_0))$ for some $v'_0 \in f^{-1}(u_0)$. Note that $f^b \equiv f$ and it follows that $\varphi_{f^b}^{v_0}(x) = b\varphi_f^{v_0}(x)b^{-1}$ for any $x \in \pi_1(\mathbb{A}, v_0)$ implying that $\varphi_{f^b}^{v_0}(\pi_1(\mathbb{A}, v_0)) = \varphi_f^{v_0}(\pi_1(\mathbb{A}, v_0))^{b^{-1}} = U^{b^{-1}} = \varphi_f^{v'_0}(\pi_1(\mathbb{A}, v'_0))$. Applying Lemma 3.56 there exists some graph of group automorphism $h : \mathbb{A} \rightarrow \mathbb{A}$ such that $f \circ h \stackrel{v_0}{\cong} f^b$.
2. Let $h^1, h^2 : \mathbb{A} \rightarrow \mathbb{A}$ be automorphisms satisfying $f \circ h^i \stackrel{v_0}{\cong} f^b$ and $h^i(v_0) = v'_0$ for $i \in \{1, 2\}$. Thus $\varphi_{f^b}^{v'_0} \circ \varphi_{h^1}^{v_0} = \varphi_{f^b}^{v_0} = \varphi_{f^b}^{v'_0} \circ \varphi_{h^2}^{v_0}$ and $f_{h^1}^{v'_0} \circ f_{h^1}^{v_0} = f_{h^2}^{v_0} = f_{h^2}^{v'_0} \circ f_{h^2}^{v_0}$ implying that $\varphi_{h^1}^{v_0} = \varphi_{h^2}^{v_0}$ and $f_{h^1}^{v_0} = f_{h^2}^{v_0}$. Applying Lemma 3.46 it follows that $h^1 \stackrel{v_0}{\cong} h^2$ proving the claim. \square

The last statement which is needed to prove the main result of this chapter is the following.

Proposition 3.58. *Let $f : \mathbb{A} \rightarrow \mathbb{B}$ be a cover and let $U = \varphi_f^{v_0}(\pi_1(\mathbb{A}, v_0)) \leq G = \pi_1(\mathbb{B}, u_0)$. Moreover let p be an \mathbb{A} -path connecting v_0 with $v'_0 \in f^{-1}(u_0)$ and $b \in B_{u_0}$. Then the following holds:*

1. *There exists a graph of groups automorphism $h : \mathbb{A} \rightarrow \mathbb{A}$ satisfying $f \circ h \stackrel{v_0}{\cong} f^b$ and $h(v_0) = v'_0$ if and only if $g = [\mu(p)b] \in N_G(U)$.*
2. *If $[\mu(p)b] \in N_G(U)$ for some $b \in B_{u_0}$ then $[\mu(p)b'] \in N_G(U)$ if and only if $b' \in b(N_G(U) \cap B_{u_0})$.*
3. *Consider the action of G on $(\widetilde{\mathbb{B}}, u_0)$ and let $K \leq G$ be the kernel of this action. Then*

(a) $K \leq B_{u_0}$ and

(b) $f^b \stackrel{v_0}{\cong} f$ if and only if $b \in Z_G(U) \cap K$.

Proof: So let p be an \mathbb{A} -path connecting v_0 with $v'_0 \in f^{-1}(u_0)$ and let $b \in B_{u_0}$.

1. Assume that $[\mu(p)b] = g \in N_G(U)$. Then $U^g = U$ implies that

$$U^{b^{-1}} = [\mu(p)^{-1}]U[\mu(p)] = \varphi_f^{v'_0}([p^{-1}]\pi_1(\mathbb{A}, v_0)[p]) = \varphi_f^{v'_0}(\pi_1(\mathbb{A}, v'_0)).$$

As before let $f^b : \mathbb{A} \rightarrow \mathbb{B}$ be the cover obtained from f by performing the auxiliary modification of the second type corresponding to b in v_0 .

Then by Corollary 3.57 there exists some graph of group automorphism $\mathfrak{h} : \mathbb{A} \rightarrow \mathbb{A}$ such that $\mathfrak{f} \circ \mathfrak{h} \stackrel{v_0}{\cong} \mathfrak{f}^b$. Note that this implies $\mathfrak{f} \circ \mathfrak{h} \equiv \mathfrak{f}$.

Let conversely $\mathfrak{f} \circ \mathfrak{h} \equiv \mathfrak{f}^b$ and $h(v_0) = v'_0$ for some graph of group automorphism $\mathfrak{h} : \mathbb{A} \rightarrow \mathbb{A}$. Then it follows that

$$\begin{aligned} [\mu(p)^{-1}]U[\mu(p)] &= \varphi_{\mathfrak{f}}^{h(v_0)}([p^{-1}]\pi_1(\mathbb{A}, v_0)[p]) = \varphi_{\mathfrak{f}}^{h(v_0)}(\pi_1(\mathbb{A}, h(v_0))) \\ &= \varphi_{\mathfrak{f}}^{h(v_0)} \circ \varphi_{\mathfrak{h}}^{v_0} \circ (\varphi_{\mathfrak{h}}^{v_0})^{-1}(\pi_1(\mathbb{A}, h(v_0))) = \varphi_{\mathfrak{f}}^{h(v_0)} \circ \varphi_{\mathfrak{h}}^{v_0} \circ \varphi_{\mathfrak{h}^{-1}}^{h(v_0)}(\pi_1(\mathbb{A}, h(v_0))) \\ &= \varphi_{\mathfrak{f} \circ \mathfrak{h}}^{v_0}(\pi_1(\mathbb{A}, v_0)) = (\varphi_{\mathfrak{f}}^{v_0}(\pi_1(\mathbb{A}, v_0)))^{b^{-1}} = U^{b^{-1}}. \end{aligned}$$

implying that $g = [\mu(p) \cdot b] \in N_G(U)$.

2. So assume again that $[\mu(p)b] \in N_G(U)$. Clearly $[\mu(p)b'] \in N_G(U)$ if $b' = b \cdot b''$ for some $b'' \in N_G(U) \cap B_{u_0}$. So assume that $[\mu(p)b'] \in N_G(U)$. Then

$$U = [b'^{-1}bb^{-1}\mu(p)^{-1}]U[\mu(p)bb^{-1}b'] = [b'^{-1}b]U[b^{-1}b']$$

implying that $b^{-1}b' \in N_G(U) \cap B_{u_0}$ and therefore $b' \in b(N_G(U) \cap B_{u_0})$.

3. Obviously K can be regarded as a subgroup of B_{u_0} since K fixes any point in T . Moreover by Lemma 3.46 $f^b \stackrel{v_0}{\cong} \mathfrak{f}$ if and only if

$$b\varphi_{\mathfrak{f}}^{v_0}([p])b^{-1} = \varphi_{\mathfrak{f}^b}^{v_0}([p]) = \varphi_{\mathfrak{f}}^{v_0}([p])$$

for any $p \in \Sigma_{v_0}^{v_0}$ and

$$b \cdot f_{\mathfrak{f}}^{v_0}([p]A_v) = f_{\mathfrak{f}^b}^{v_0}([p]A_v) = f_{\mathfrak{f}}^{v_0}([p]A_v)$$

for any $p \in \Sigma_{v_0}^v$, $v \in VA$, which is equivalent to $b \in Z_G(U) \cap K$, since $f_{\mathfrak{f}}^{v_0}$ is an isomorphism of trees. \square

Now we are able to prove the following group theoretical relation between the normalizer of some subgroup $U \leq \pi_1(\mathbb{B}, u_0)$ represented by some cover $\mathfrak{f} : \mathbb{A} \rightarrow \mathbb{B}$ and the group of Deektransformations of \mathfrak{f} .

As discussed in the proof of Theorem 3.41 for any $[q] \in \pi_1(\mathbb{B}, u_0)$ there exists a vertex $w \in f^{-1}(u_0)$, an \mathbb{A} -path p connecting v_0 with w and some $b \in B_{u_0}$ such that $[q] = [\mu(p)b]$.

Theorem 3.59. *Let $\mathfrak{f} : \mathbb{A} \rightarrow \mathbb{B}$ be a cover and $U = \varphi_{\mathfrak{f}}^{v_0}(\pi_1(\mathbb{A}, v_0)) \leq G = \pi_1(\mathbb{B}, u_0)$. For any $g = [\mu(p) \cdot b] \in N_G(U)$ choose some equivalence class $[\mathfrak{h}_p^b] \in \text{Deck}(\mathfrak{f})$ satisfying $\mathfrak{f} \circ \mathfrak{h}_p^b \stackrel{v_0}{\cong} \mathfrak{f}^b$ with $\omega(p) = h(v_0)$. Moreover let K be the kernel of the action of G on $\widetilde{(\mathbb{B}, u_0)}$ and $Z := Z_G(U) \cap K$. Then the map*

$$\chi : N_G(U) \rightarrow \text{Deck}(\mathfrak{f}), \quad g \mapsto [\mathfrak{h}_p^b]$$

is an epimorphism of groups and $\ker(\chi) = Z \cdot U$.

Proof: Let $g = [\mu(p_1) \cdot b_1] = [\mu(p_2) \cdot b_2] \in N_G(U)$ for some \mathbb{A} -path p_i and some $b_i \in B_{u_0}$, $i \in \{1, 2\}$. Clearly $v := \omega(p_1) = \omega(p_2)$ and it follows that there exists $a \in A_v$ such that $b_2 = f_v(a)b_1$. Let $\mathfrak{h}^i := \mathfrak{h}_{p_i}^{b_i}$ for $i \in \{1, 2\}$. Hence $\mathfrak{f} \circ \mathfrak{h}^i \stackrel{v_0}{\cong} \mathfrak{f}^{b_i}$ for $i \in \{1, 2\}$ and it follows

$$\mathfrak{f} \circ (\mathfrak{h}^1)^a = (\mathfrak{f} \circ \mathfrak{h}^1)^{f_v(a)} \stackrel{v_0}{\cong} \mathfrak{f}^{f_v(a)b_1} = \mathfrak{f}^{b_2} \stackrel{v_0}{\cong} \mathfrak{f} \circ \mathfrak{h}^2$$

Hence $(\mathfrak{h}^1)^a \stackrel{v_0}{\cong} \mathfrak{h}^2$ by the second assertion of Corollary 3.57. Thus $\mathfrak{h}^1 \equiv \mathfrak{h}^2$ implying that χ is well defined.

To show that χ is a homomorphism let $g_1, g_2 \in N_G(U)$ satisfying $g_i = [\mu(p_i)b_i]$ for some \mathbb{A} -path p_i and some $b_i \in B_{u_0}$, $i \in \{1, 2\}$. Then it follows for $\mathfrak{h}^i := \mathfrak{h}_{p_i}^{b_i}$, $i \in \{1, 2\}$, that $p_1 \cdot \mu_{\mathfrak{h}^1}(p_2)$ is an \mathbb{A} -path connecting v_0 with $h^1 \circ h^2(v_0)$.

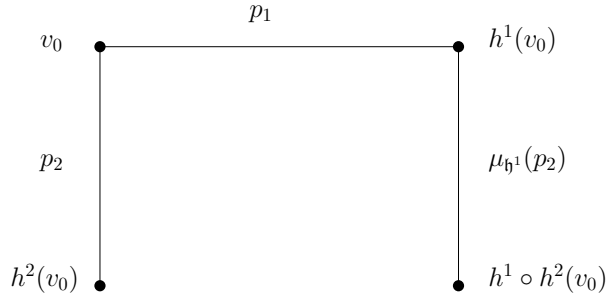

Figure 2: The path $p_1 \cdot \mu_{\mathfrak{h}^1}(p_2)$ connects v_0 with $h^1 \circ h^2(v_0)$.

Let $v_i := h^i(v_0)$ for $i \in \{1, 2\}$ and $v_{1,2} = h^1 \circ h^2(v_0)$. Then by Proposition 3.58.1 combined with Corollary 3.54 it follows that $\mathfrak{f}^{b_i} \stackrel{v_0}{\cong} \mathfrak{f} \circ \mathfrak{h}^i \stackrel{v_0}{\cong} \mathfrak{f}^{b_{v_i}^{h^i}}$. Thus Proposition 3.58.3 implies $z_i := (b_{v_i}^{h^i})^{-1}b_i \in Z$ for $i \in \{1, 2\}$. Hence by 3.54.1 we deduce

$$\begin{aligned} g_1 \cdot g_2 &= [\mu_{\mathfrak{f}}(p_1)b_1][\mu_{\mathfrak{f}}(p_2)b_2] = [\mu_{\mathfrak{f}}(p_1)b_1\mu_{\mathfrak{f}}(p_2)b_2] \\ &\stackrel{3.54.1}{=} [\mu_{\mathfrak{f}}(p_1)b_1 \underbrace{(b_{v_1}^{h^1})^{-1}(b_1 b_1^{-1})}_{= z_1 \in Z} \mu_{\mathfrak{f}}(\mu_{\mathfrak{h}^1}(p_2))b_{v_{1,2}}^{h^1}b_{v_2}^{h^2}z_2] \end{aligned}$$

As now $g_1g_2 \in N_G(U)$ it follows $g := [b_1^{-1}\mu_{\mathfrak{f}}(\mu_{\mathfrak{h}^1}(p_2))b_{v_{1,2}}^{h^1}b_{v_2}^{h^2}z_2] \in N_G(U)$. Thus $z_1^g = g^{-1}z_1g \in Z$ as obviously $Z \trianglelefteq N_G(U)$. Hence we deduce

$$g_1 \cdot g_2 = [\mu_{\mathfrak{f}}(p_1)b_1]z_1g = [\mu_{\mathfrak{f}}(p_1)b_1]gz_1^g = [\mu_{\mathfrak{f}}(p_1 \cdot \mu_{\mathfrak{h}^1}(p_2))b_{v_{1,2}}^{h^1}b_{v_2}^{h^2}(z_2z_1^g)].$$

By definition it follows for $[\mathfrak{h}^3] = \chi(g_1g_2)$ and $z := z_2z_1^g \in Z$ that

$$\mathfrak{f} \circ \mathfrak{h}^3 \stackrel{v_0}{\cong} \mathfrak{f}^{b_{v_{1,2}}^{h^1}b_{v_2}^{h^2}z} \stackrel{v_0}{\cong} \mathfrak{f}^{b_{v_{1,2}}^{h^1}b_{v_2}^{h^2}}$$

since $z \in Z$ and we conclude by Corollary 3.57.2 combined with 3.55 that

$$[\mathfrak{h}^3] = [\mathfrak{h}^1 \circ \mathfrak{h}^2] = [\mathfrak{h}^1] \circ [\mathfrak{h}^2] = \chi(g_1) \circ \chi(g_2)$$

proving that χ is a homomorphism.

For surjectivity let $[\mathfrak{h}] \in \text{Deck}(\mathfrak{f})$. Hence $\mathfrak{f} \circ \mathfrak{h} \equiv \mathfrak{f}$ implying that there exists $b \in B_{u_0}$ satisfying $\mathfrak{f} \circ \mathfrak{h} \stackrel{v_0}{\equiv} \mathfrak{f}^b$. Choose an arbitrary \mathbb{A} -path p originating at v_0 and terminating at $h(v_0)$. Then it follows $g := [\mu(p)b] \in N_G(U)$ and $\chi(g) = [\mathfrak{h}]$. Thus the map χ is an epimorphism.

To determine $\ker(\chi)$ let $[\mu(p)b] = g \in N_G(U)$ such that $\mathfrak{h} := \mathfrak{h}_p^b \equiv \text{id}$. Thus $\omega(p) = v_0$ and therefore $[\mu(p)] \in U$. Moreover there exists $a \in A_{v_0}$ such that $\mathfrak{h}^a \stackrel{v_0}{\equiv} \text{id}$ implying that

$$\mathfrak{f} = \mathfrak{f} \circ \text{id} \stackrel{v_0}{\equiv} \mathfrak{f} \circ \mathfrak{h}^a = (\mathfrak{f} \circ \mathfrak{h})^{f_{v_0}(a)} \stackrel{v_0}{\equiv} \mathfrak{f}^{f_{v_0}(a)b}.$$

Hence $f_{v_0}(a)b \in Z$ by the third assertion of Proposition 3.58 and therefore

$$g = [\mu(p)b] = [\mu(p)f_{v_0}(a^{-1})][f_{v_0}(a)b] \in U \cdot Z = Z \cdot U.$$

Thus $\ker(\chi) \subseteq ZU$.

Let conversly $g \in UZ$. Then there exists a closed \mathbb{A} -path p originating at v_0 and some $b \in Z$ such that $g = [\mu(p)b]$ and it follows for $\mathfrak{h} := \mathfrak{h}_p^b$ that

$$\mathfrak{f} \circ \mathfrak{h} \stackrel{v_0}{\equiv} \mathfrak{f}^b \stackrel{v_0}{\equiv} \mathfrak{f} = \mathfrak{f} \circ \text{id}.$$

Thus $\mathfrak{h} \stackrel{v_0}{\equiv} \text{id}$ by Corollary 3.57 implying that $\mathfrak{h} \equiv \text{id}$ and we conclude that $\ker(\chi) = ZU$ proving the claim. \square

3.5 Structure of a covering of graphs of groups

3.5.1 Double Cosets

As mentioned in section 3.3 it is possible to characterize a covering of graphs of groups by local properties. In this context double cosets play an important role. Hence we will repeat the following statements:

Definition 3.60. *Let G be a group.*

1. We set $A^g := g^{-1}Ag$ for any $A \leq G$ and $g \in G$.
2. For $A, B \leq G$ and $g \in G$ we call $A \cdot g \cdot B$ the double coset of G related to A and B . We define $A \backslash G / B := \{AgB \mid g \in G\}$ to be the set of double cosets of G with respect A and B .

Lemma 3.61. *Let G be a group, $A, B \leq G$ and $g_1, g_2 \in G$. Then the following holds:*

1. $Ag_1B \cap Ag_2B = \emptyset$ or $Ag_1B = Ag_2B$. In particular $g_1 \sim g_2$ if and only if $Ag_1B = Ag_2B$ is a equivalence relation on the set G .

If G is a finite group it follows:

2. For any $g \in G$ we have

$$|AgB| = \frac{|A| \cdot |B|}{|A^g \cap B|} = \frac{|A| \cdot |B|}{|A \cap B^{g^{-1}}|}.$$

3. The number of right cosets of A in G , which are contained in AgB , $g \in G$, equals the index of the subgroup $A^g \cap B$ in B . Similarly the number of left cosets of B in G , contained in AgB , is equal to the index of $A \cap B^{g^{-1}}$ in A .

Proof:

1. Let $g_1 \in Ag_2B$. Then there exists $a \in A$ and $b \in B$ with $g_1 = ag_2b$. Hence $Ag_1B = Aag_2bB = Ag_2B$. If $g \in Ag_1B \cap Ag_2B \neq \emptyset$ it follows that $Ag_1B = AgB = Ag_2B$. Obviously it follows that \sim is an equivalence relation.
2. Let A and B be finite groups. Then G acts on the set of right cosets of A in G $\Omega := \{Ag|g \in G\}$ by right multiplication:

$$\cdot : \Omega \times G \rightarrow \Omega; (Ag, x) \mapsto Ag \cdot x = Agx.$$

Let $Ag \in \Omega$ and $x \in \text{Stab}_G(Ag) := \{x \in G | Ag \cdot x = Ag\}$. Then there exists $a \in A$ s.t. $gx = ag$. Hence $x \in A^g$. Clearly we have that $A^g \subseteq \text{Stab}_G(Ag)$ and therefore $\text{Stab}_G(Ag) = A^g$. Consider the induced action of the subgroup B on Ω . We deduce that $\text{Stab}_B(Ag) = \text{Stab}_G(Ag) \cap B = A^g \cap B$. So let $(Ag).B := \{Ag' | \exists b \in B : Ag' = Ag \cdot b\}$ be the orbit of $Ag \in \Omega$ with respect to the action of B on Ω . Since B is finite, it follows that $|B| = |\text{Stab}_B(Ag)| \cdot |(Ag).B|$. Furthermore $|AgB| = |(Ag).B| \cdot |A|$ and therefore $|AgB| = |(Ag).B| \cdot |A| = \frac{|B|}{|A^g \cap B|} \cdot |A|$. Since $(A^g \cap B)^{g^{-1}} = A \cap B^{g^{-1}}$ we obtain the second equality.

3. By 2. it follows that $|(Ag).B| = \frac{|B|}{|A^g \cap B|}$. The second statement now follows similarly by analyzing the action of G and A on the left cosets of B in G . \square

Remark 3.62. Let G be a group and $A, B \leq G$. Since \sim is an equivalence relation, we obtain that G is the disjoint union of the double cosets $A \setminus G / B$. That means there exists a subset $X \subseteq G$, s.t. $G = \bigcup_{g \in X} AgB$.

Lemma 3.63. Let G be a group and let $A, B \leq G$.

1. Then the relation $g_1 \approx g_2$ if and only if there exists $b \in B$ with $A^{g_1} \cap B = (A^{g_2} \cap B)^b$ is an equivalence relation on the set G .
2. \sim is an refinement of \approx , that means $g_1 \sim g_2$ implies $g_1 \approx g_2$.
3. If $g_1 \in G$ we find for any $b \in B$ some $g_2 \in Ag_1B$, s.t. $(A^{g_1} \cap B)^b = (A^{g_2} \cap B)$.

Proof: Obviously \approx is an equivalence relation. To show the second property let $g_1, g_2 \in G$ with $g_1 \sim g_2$. Then it follows $Ag_1B = Ag_2B$. Therefore there exists $a \in A$ and $b \in B$ with $g_1 = ag_2b$ and we obtain

$$A^{g_1} \cap B = A^{ag_2b} \cap B = A^{g_2b} \cap B^b = (A^{g_2} \cap B)^b.$$

Hence $g_1 \approx g_2$. For the proof of 3. set $g_2 = g_1b \in Ag_1B$. Then we conclude that

$$(A^{g_2} \cap B) = (A^{g_1b} \cap B^b) = (A^{g_1} \cap B)^b.$$

\square

Moreover we observe the following:

Remark 3.64. Let $A, B \leq G$ and let $X \subseteq G$ such that $G = \bigcup_{g \in X} AgB$. Let $y \in G$ and set $Y := y^{-1}X$. Then it follows that $G = y^{-1}G = \bigcup_{g \in X} A^y y^{-1}gB = \bigcup_{g \in Y} A^y gB$. Moreover we have that $A^g \cap B = A^{y(y^{-1}g)} \cap B$. \square

Lemma 3.65. *Let G be a finite group and $A, B \leq G$. Then G acts on $\Omega_1 := \{Ag | g \in G\}$ and $\Omega_2 := \{Bg | g \in G\}$ by right multiplication. This induces an action of G on $\Omega := \Omega_1 \times \Omega_2$. So let*

$$\cdot : \Omega \times G \rightarrow \Omega; [(Ag_1, Bg_2), x] \mapsto (Ag_1 \cdot x, Bg_2 \cdot x).$$

and let G/Ω the set of G -orbits related to this action. Then the map

$$\phi : G/\Omega \rightarrow A \backslash G/B; (Ag_1, Bg_2)^G \mapsto Ag_1g_2^{-1}B$$

is a bijection between the set of G -orbits in Ω and the set of double cosets $A \backslash G/B$.

Proof:

1. *ϕ is well defined:* Let $(Ah_1, Bh_2) \in (Ag_1, Bg_2)^G$. Then it follows for $g := g_1g_2^{-1}$ and $h := h_1h_2^{-1}$ that $(Ag, B), (Ah, B) \in (Ag_1, Bg_2)^G$ s.t. $\phi((Ag, B)^G) = \phi(Ag_1, Bg_2)^G$ and $\phi((Ah, B)^G) = \phi(Ah_1, Bh_2)^G$. Since $(Ag, B), (Ah, B) \in (Ag_1, Bg_2)^G$ there exists $x \in G$ with $(Ag, B)^x = (Agx, Bx) = (Ah, B)$. It follows that $x \in B$. Hence $h \in Ah \subseteq AgB$ and therefore $AhB = AgB$. We conclude that ϕ is well-defined.
2. *Injectivity:* Let $\phi((Ag_1, Bg_2)^G) = \phi((Ah_1, Bh_2)^G)$. Then it follows again for $g := g_1g_2^{-1}$ and $h := h_1h_2^{-1}$ that $(Ag_1, Bg_2)^G = (Ag, B)^G$ and $(Ah_1, Bh_2)^G = (Ah, B)^G$. Now since $AgB = AhB$ there exists $a \in A$ and $b \in B$ s.t. $h = agb$. Hence we deduce that $(Ag, B)^b = (Ah, B)$ and therefore $(Ag, B)^G = (Ah, B)^G$.
3. *Surjectivity:* For any $g \in G$ it follows that $(Ag, B)^G \in G/\Omega$ with $\phi((Ag, B)^G) = AgB$. □

3.5.2 Characterising a covering by local properties

By Theorem 3.35 we know that any f.g. subgroup of the fundamental group of a graph of groups \mathbb{B} can be represented by a folded graph of group morphism $\mathfrak{f} : \mathbb{A} \rightarrow \mathbb{B}$ such that the underlying graph of \mathbb{A} is finite. In addition, we have seen that for any finite index subgroup there exists a finite covering representing it. To enable us to construct coverings of graphs of groups, we will now discuss the local structure of coverings of graphs of groups. We start with the following proposition about folded graphs of groups morphisms.

Proposition 3.66. *A morphism $\mathfrak{f} : \mathbb{A} \rightarrow \mathbb{B}$ is folded if and only if*

1. *\mathfrak{f} is injective on vertices and therefore on edges.*
2. *F.a. $e_1 \neq e_2 \in EA$ with $\alpha(e_1) = \alpha(e_2) = v$ and $f(e_1) = f(e_2) = l$ we have:*

$$f_v(A_v) \cdot g_{e_1}^\alpha \cdot \alpha_l(B_l) \cap f_v(A_v) \cdot g_{e_2}^\alpha \cdot \alpha_l(B_l) = \emptyset.$$

3. *Let $e \in EA$ with $v := \alpha(e)$, $l := f(e)$ and $u := f(v)$. Then it follows*

$$f_v(\alpha_e(A_e)) = f_v(A_v) \cap g_e^\alpha \cdot \alpha_l(B_l) \cdot (g_e^\alpha)^{-1}.$$

Proof: At first we will show that the third property is not satisfied if and only if the third condition of Lemma 3.33 holds. Since \mathfrak{f} is a morphism, it follows that

$$f_v(\alpha_e(A_e)) = g_e^\alpha \cdot \alpha_l(f_e(A_e)) \cdot (g_e^\alpha)^{-1} \leq f_v(A_v) \cap g_e^\alpha \cdot \alpha_l(B_l) \cdot (g_e^\alpha)^{-1}. \quad (*)$$

So let $e \in EA$, $\alpha(e) = v$, $f(e) = l$ and $f(v) = u$. Suppose that there exists $a \in A_v \setminus \alpha_e(A_e)$ s.t.

$$f_v(a) \cdot g_e^\alpha \cdot \alpha_l(B_l) = g_e^\alpha \cdot \alpha_l(B_l)$$

If we set $X := g_e^\alpha \cdot \alpha_l(B_l) \cdot (g_e^\alpha)^{-1}$, the previous equation is equivalent to

$$f_v(a) \cdot X \cdot g_e^\alpha = X \cdot g_e^\alpha$$

and this equation is satisfied if and only if

$$f_v(a) \cdot X = X$$

But this is the same as $f_v(a) \in g_e^\alpha \cdot \alpha_l(B_l) \cdot (g_e^\alpha)^{-1}$, which is equivalent to $f_v(a) \in f_v(A_v) \cap g_e^\alpha \cdot \alpha_l(B_l) \cdot (g_e^\alpha)^{-1}$. Since $a \notin \alpha_e(A_e)$ and hence $f_v(a) \notin f_e(\alpha_e(A_e))$ the previous statement holds if and only if

$$f_v(\alpha_e(A_e)) < f_v(A_v) \cap g_e^\alpha \cdot \alpha_l(B_l) \cdot (g_e^\alpha)^{-1}.$$

To complete the proof, we show that the second condition of Lemma 3.33 holds if and only if the second property is not satisfied. So let $e_1 \neq e_2 \in EA$ with $\alpha(e_1) = \alpha(e_2) = v$ and

$$f_v(a_1) \cdot g_{e_1}^\alpha \cdot \alpha_l(b_1) = f_v(a_2) \cdot g_{e_2}^\alpha \cdot \alpha_l(b_2)$$

s.t. $a_1, a_2 \in A_v$ and $b_1, b_2 \in B_l$.

If we set $a := a_1^{-1} \cdot a_2$ this is true if and only if $g_{e_1}^\alpha$ and $f(a) \cdot g_{e_2}^\alpha$ represent the same left cosets of $\alpha_l(B_l)$ in $B_{f(v)}$, which is equivalent to

$$g_{e_1}^\alpha \cdot \alpha_l(B_l) = f_v(a) \cdot g_{e_2}^\alpha \cdot \alpha_l(B_l).$$

□

Remark 3.67. Any subgroup U of the fundamental group $\pi_1(\mathbb{B}, u_0)$ acts on the associated Bass-Serre tree $(\widetilde{\mathbb{B}}, u_0)$. Clearly, the vertex and edge stabilizers corresponding to this action of U on $(\widetilde{\mathbb{B}}, u_0)$ are subgroups of the vertex and edge stabilizers corresponding to the action of $\pi_1(\mathbb{B}, u_0)$ on $(\widetilde{\mathbb{B}}, u_0)$. Furthermore, we know that the intersection of the stabilizers of two adjacent vertices is the stabilizer of the corresponding edge (see 3.22). If now $U = \varphi_{\mathfrak{f}}(\pi_1(\mathbb{A}, v_0))$ this fact is ensured by the third condition of Proposition 3.66.

Since any covering of graphs of groups is also a folded morphism with the additional condition that the injective map on tree level is already bijective, we obtain the following statement.

Theorem 3.68. A morphism $\mathfrak{f} : \mathbb{A} \rightarrow \mathbb{B}$ between two finite graphs of groups \mathbb{A} and \mathbb{B} is a covering if and only if the following (local) conditions are satisfied:

1. \mathfrak{f} is injective on vertices and therefore on edges.

2. Let $v \in VA$, $u := f(v)$ and $l \in EB$ with $\alpha(l) = u$. Then it follows

$$f^{-1}(l)_v := \{e \in f^{-1}(l) : \alpha(e) = v\} \neq \emptyset$$

and we have

$$B_u = \bigcup_{e \in f^{-1}(l)_v} f_v(A_v) \cdot g_e^\alpha \cdot \alpha_l(B_l).$$

3. Let $e \in EA$ with $v := \alpha(e)$, $l := f(e)$ and $u := f(v)$. Then it holds

$$f_v(\alpha_e(A_e)) = f_v(A_v) \cap g_e^\alpha \cdot \alpha_l(B_l) \cdot (g_e^\alpha)^{-1}.$$

Proof: Note that these conditions are nearly the same as in the proposition before except that in the second part we have that the vertex group B_u is the (disjoint) union of the sets $f_v(A_v) \cdot g_e^\alpha \cdot \alpha_l(B_l)$ for $l \in EB$ with $\alpha(l) = u$, s.t. the elements g_e^α correspond to the preimages of some edge l with origin in $v \in VA$. So we only have to show that this additional property is equivalent to the fact, that the induced map $f_{\mathfrak{f}}$ is surjective.

Assume that second condition holds and that $f_{\mathfrak{f}}$ is not surjective. Thus we find some edge $(x, l, x') \in E(\mathbb{B}, u_0) \setminus \text{Im}(f_{\mathfrak{f}})$ for some $l \in EB$ with $u := \alpha(l)$ and $u' := \omega(l)$, such that $x = [\mu(p)]B_u \in \text{Im}(f_{\mathfrak{f}})$ for some \mathbb{A} -path p . Since $(x, l, x') \in E(\mathbb{B}, u_0)$ there exists some $b \in B_u$ such that $x' = [\mu(p)][b, l, 1_{B_{u'}}]B_{u'}$. Let $\omega(p) = v$. By the second condition there exists $e \in f^{-1}(l)_v$ with $v' := \omega(e)$ satisfying $b \in f_v(A_v) \cdot g_e^\alpha \cdot \alpha_l(B_l)$. Hence we find some $a \in A_v$ and $b' \in B_l$ with $b = f_v(a) \cdot g_e^\alpha \cdot \alpha_l(b')$ and it follows

$$f_{\mathfrak{f}}([p] \cdot [a, e, 1_{A_{v'}}]A_{v'}) = [\mu(p)][f_v(a) \cdot g_e^\alpha \cdot \alpha_l(b'), l, \omega_l(b')^{-1}]B_{u'} = x' \in \text{Im}(f_{\mathfrak{f}})$$

and therefore $(x, l, x') \in f_{\mathfrak{f}}$. A contradiction. We conclude that $f_{\mathfrak{f}}$ is surjective and therefore bijective.

Conversly assume that $f_{\mathfrak{f}}$ is a bijective map and hence surjective. Let $l \in EB$ s.t. $\alpha(l) = u$. Suppose there exists some $v \in f^{-1}(u)$ with

$$b \in B_u \setminus \bigcup_{e \in f^{-1}(l)_v} f_v(A_v) \cdot g_e^\alpha \cdot \alpha_l(B_l).$$

W.l.o.g. let $v = v_0$. Since $f_{\mathfrak{f}}$ is bijective, we deduce that the vertex $x' = [b, l, 1_{B_{u'}}]B_{u'}$ for $u' := \omega(l)$ lies in the image of $f_{\mathfrak{f}}$. Thus there exists $e \in f^{-1}(l)_v$ and $a \in A_v$ s.t. $x' = [f_v(a) \cdot g_e^\alpha, l, 1_{B_{u'}}]B_{u'}$ and $f(\omega(e)) = u'$. We conclude that there exists $b' \in B_l$ s.t. $b = f_v(a) \cdot g_e^\alpha \cdot \alpha_l(b') \in f_v(A_v) \cdot g_e^\alpha \cdot \alpha_l(B_l)$, a contradiction. \square

If $\mathfrak{f} : \mathbb{A} \rightarrow \mathbb{B}$ is a covering, it follows that for any vertex $v \in VA$ and any edge $l \in EB$ with $\alpha(l) = f(v)$ the set $\{g_e^\alpha | e \in f^{-1}(l)_v\}$ is a double coset system (a system of representatives of the double cosets) for the double cosets of the form $f_v(A_v) \cdot x \cdot \alpha_l(B_l)$ with $x \in B_{f(v)}$. Hence Theorem 3.68 implicates a 1-1 correspondence between the set of preimages of some edge $l \in EB$ originating at some vertex $v \in VA$, $f^{-1}(l)_v$ and the set of double cosets of the form $f_v(A_v) \cdot x \cdot \alpha_l(B_l)$ with $x \in B_{f(v)}$. In the light of the discussion about double coset decompositions of a group it is know easy to see that the morphism $\mathfrak{f}' : \mathbb{A} \rightarrow \mathbb{B}$ obtained from $\mathfrak{f} : \mathbb{A} \rightarrow \mathbb{B}$ by replacing the element g_e^α by any other representative of the double coset $f_v(A_v) \cdot g_e^\alpha \cdot \alpha_l(B_l)$ for some edge $e \in f^{-1}(l)_v$, $v \in VA$, is as well cover of graphs of groups.

Remark 3.69. Let $\mathfrak{f} : \mathbb{A} \rightarrow \mathbb{B}$ be a covering and $l \in EB$ with $\alpha(l) = u$.

1. If $\alpha_l(B_l) \trianglelefteq B_u$, it follows that $f_v(A_v) \cdot \alpha_l(B_l) \leq B_u$ and therefore the set $\{g_e^\alpha : e \in f^{-1}(l)_v\}$ forms a right transversal of $f_v(A_v) \cdot \alpha_l(B_l)$ in B_u f.a. $v \in f^{-1}(u)$.
2. If $f_v(A_v) \trianglelefteq B_u$ for some $v \in f^{-1}(u)$, we have that $f_v(A_v) \cdot \alpha_l(B_l) \leq B_u$ and the set $\{g_e^\alpha : e \in f^{-1}(l)_v\}$ forms a left transversal of $f_v(A_v) \cdot \alpha_l(B_l)$ in B_u f.a. $v \in f^{-1}(u)$.
3. If $g_e^\alpha \cdot \alpha_l(B_l) \cdot (g_e^\alpha)^{-1} \leq f_v(A_v)$ f.a. $e \in f^{-1}(l)_v$, it follows that $\{g_e^\alpha : e \in f^{-1}(l)_v\}$ is a right transversal of $f_v(A_v)$ in B_u . This is for example true if $f_v(A_v) \trianglelefteq B_u$ and $\alpha_l(B_l) \leq f_v(A_v)$.

Remark 3.70. Let $\mathfrak{f} : \mathbb{A} \rightarrow \mathbb{B}$ be a covering, $l \in EB$ with $\alpha(l) = u$ and $\omega(l) = u'$. Then for any $e \in f^{-1}(l)$ with $\alpha(e) = v \in f^{-1}(u)$ and $\alpha(e) = v' \in f^{-1}(u')$ it follows that

$$\alpha_e^{-1}(f_v(A_v) \cap g_e^\alpha \cdot \alpha_l(B_l) \cdot (g_e^\alpha)^{-1}) = \omega_e^{-1}(f_{v'}(A_{v'}) \cap (g_e^\omega)^{-1} \cdot \omega_l(B_l) \cdot g_e^\omega).$$

Since we are interested in the subgroups of finite index of the fundamental group \mathbb{B} , we can assume w.l.o.g. that f.a. $y \in f^{-1}(x)$ we have $A_y \leq B_x$ for some $x \in EB \cup VB$. Then the previous equality implies:

1. $\alpha_e(A_e) = g_e^\alpha \cdot \alpha_l(A_e) \cdot (g_e^\alpha)^{-1} = A_v \cap g_e^\alpha \cdot \alpha_l(B_l) \cdot (g_e^\alpha)^{-1} \leq A_v$,
2. $\omega_e(A_e) = (g_e^\omega)^{-1} \cdot \omega_l(A_e) \cdot g_e^\omega = A_{v'} \cap (g_e^\omega)^{-1} \cdot \omega_l(B_l) \cdot g_e^\omega \leq A_{v'}$,
3. $A_e = \alpha_e^{-1}(A_v \cap g_e^\alpha \cdot \alpha_l(B_l) \cdot (g_e^\alpha)^{-1}) = \alpha_l^{-1}((g_e^\alpha)^{-1} \cdot A_v \cdot g_e^\alpha \cap \alpha_l(B_l))$,
4. $A_e = \omega_e^{-1}(A_{v'} \cap (g_e^\omega)^{-1} \cdot \omega_l(B_l) \cdot g_e^\omega) = \omega_l^{-1}(g_e^\omega \cdot A_{v'} \cdot (g_e^\omega)^{-1} \cap \omega_l(B_l))$.

The following statement is easy to check.

Lemma 3.71. Let \mathbb{B} be a graph of groups, $u_0 \in VB$ and U be a subgroup of $G := \pi_1(\mathbb{B}, u_0)$. Let U be represented by the folded morphism $\mathfrak{f} : \mathbb{A} \rightarrow \mathbb{B}$. Then for any subgroup $H \leq G$ with $U \leq H$ there exists a graph of groups \mathbb{C} and folded morphisms $\mathfrak{h} : \mathbb{A} \rightarrow \mathbb{C}$, $\mathfrak{g} : \mathbb{C} \rightarrow \mathbb{B}$, s.t. there exists $v_0 \in VA$ and $w_0 \in VC$ with $\varphi_{\mathfrak{g}} \circ \varphi_{\mathfrak{h}}(\pi_1(\mathbb{A}, v_0)) = U$ and $\varphi_{\mathfrak{g}}(\pi_1(\mathbb{C}, w_0)) = H$. If in addition $|G : H| < \infty$, it follows that \mathfrak{g} is a finite-sheeted cover of graphs of groups. \square

Recall that any vertex group B_u for some vertex $u \in VB$ can be embedded in the fundamental group $\pi_1(\mathbb{B}, u_0)$, $u_0 \in VB$, of some graph of groups \mathbb{B} :

Remark 3.72. Let \mathbb{B} be a graph of groups. Let $u_0, u \in VB$ and q be a \mathbb{B} -path connecting u_0 with u . Then by 3.15 the map $\phi : B_u \rightarrow \pi_1(\mathbb{B}, u_0)$; $g \mapsto [q \cdot g \cdot q^{-1}]$ is a monomorphism.

If now $U = \phi(B'_u)$ for some subgroup $B'_u \leq B_u$ then Lemma 3.71 implies that there exists a finite-sheeted cover $\mathfrak{g} : \mathbb{C} \rightarrow \mathbb{B}$, s.t. (after some suitable auxiliary modification if necessary, see 3.45.3) there exists a vertex $w \in VC$ with $B'_u \leq f_w(C_w) \leq B_u$.

Definition 3.73. Let \mathbb{C} be graph of groups. We call a graph of groups \mathbb{A} a subgraph of groups of \mathbb{C} if the following holds:

1. $VA \subseteq VC$ and $EA \subseteq EC$,
2. $A_x \leq C_x$ for any $x \in VA \cup EA$.

3. $\alpha_e^{\mathbb{A}} = \alpha_e^{\mathbb{C}}|_{A_e}$ and $\omega_e^{\mathbb{A}} = \omega_e^{\mathbb{C}}|_{A_e}$ for any $e \in EA$ if $\alpha_e^{\mathbb{A}}, \omega_e^{\mathbb{A}}$ and $\alpha_e^{\mathbb{C}}, \omega_e^{\mathbb{C}}$ are the related boundary monomorphisms corresponding to \mathbb{A} and \mathbb{C} for any $e \in EA$.

Moreover we will call \mathbb{A} the subgraph of groups induced by the subgraph A of \mathbb{C} if $A_x = C_x$ for any $x \in VA \cup EA$. Note that most of the time we will omit the superscript in the maps $\alpha_e^{\mathbb{A}}, \omega_e^{\mathbb{A}}$ and $\alpha_e^{\mathbb{C}}, \omega_e^{\mathbb{C}}$ if it is obvious which map is used in the context.

Definition 3.74. Let $\mathfrak{f} : \tilde{\mathbb{A}} \rightarrow \mathbb{B}$ be a folded morphism of graphs of groups representing some subgroup $U = \varphi_{\mathfrak{f}}(\pi_1(\mathbb{A}, v_0))$ of $G = \pi_1(\mathbb{B}, u_0)$. A connected subgraph of groups \mathbb{A} is called a core with respect to v_0 if \mathbb{A} contains v_0 , $\mathfrak{f}|_{\mathbb{A}}$ represents U and \mathbb{A} contains no proper subgraph of groups satisfying this conditions. We denote this subgraph of groups by $\text{core}(\tilde{\mathbb{A}}, v_0)$.

Definition 3.75. Let \mathbb{B} be a graph of groups with finite underlying graph B .

1. Let $\mathfrak{f} : \mathbb{A} \rightarrow \mathbb{B}$ be a folded graphs of groups morphism representing the subgroup $U \leq G := \pi_1(\mathbb{B}, u_0)$, s.t. the underlying graph A of \mathbb{A} is finite. Then we call \mathfrak{f} **weakly almost geometric**, if there exists a finite-sheeted covering of graphs of groups $\mathfrak{g} : \mathbb{C} \rightarrow \mathbb{B}$ and some subgraph of groups \mathbb{A}' of \mathbb{C} isomorphic to \mathbb{A} s.t. $\mathfrak{g}|_{\mathbb{A}'} \circ \mathfrak{h} = \mathfrak{f}$ for some suitable isomorphism of graphs of groups $\mathfrak{h} : \mathbb{A} \rightarrow \mathbb{A}'$. We say \mathfrak{f} is weakly almost geometric realized by \mathfrak{g} .
2. If in addition $A'_x = C_x$ for any $x \in VA' \cup EA'$ we call $\mathfrak{f} : \mathbb{A} \rightarrow \mathbb{B}$ **almost geometric**.
3. We call a f.g. subgroup U of the fundamental group of \mathbb{B} **(weakly) almost geometric**, if there exists a(n) **(weakly) almost geometric** morphism \mathfrak{f} representing U .
4. We say that a subgroup $B'_u \leq B_u$, $u \in VB$, of a vertex group is **(weakly) almost geometric** if the associated (canonical) graph of group morphism $\mathfrak{f} : \mathbb{A} \rightarrow \mathbb{B}$ with $VA = \{v\}$, $A_v = B'_u$, $EA = \emptyset$, $f(v) = u$ and $f_v = \text{id}$ is **(weakly) almost geometric**.

Note that this is the case if and only if the subgroup $U = [q \cdot B'_u \cdot q^{-1}] \leq \pi_1(\mathbb{B}, u_0)$ is **(weakly) almost geometric** for some (and therefore for any) \mathbb{B} -path q connecting u_0 with u .

5. We say that \mathbb{B} has property \mathcal{L} if for any folded morphism $\mathfrak{f} : \mathbb{A} \rightarrow \mathbb{B}$ of finite graphs of groups and any $b \in B_{f(v)} \setminus f_v(A_v)$ for some $v \in VA$, \mathfrak{f} is weakly almost geometric realized by some $\mathfrak{g} : \mathbb{C} \rightarrow \mathbb{B}$ such that $b \notin g_v(C_v)$ (here we can regard v as vertex of VC since $VA \subseteq VC$, if \mathbb{A} is almost geometric realized by \mathbb{C}).

Theorem 3.76. Let \mathbb{B} be a finite graph of groups. Then the following properties are equivalent:

1. For any folded morphism $\mathfrak{f} : \mathbb{A} \rightarrow \mathbb{B}$ of finite graphs of groups representing some subgroup U and any finite set $X \subseteq G \setminus U$ of elliptic elements, \mathfrak{f} is weakly almost geometric realized by some $\mathfrak{g} : \mathbb{C} \rightarrow \mathbb{B}$ representing some subgroup H containing U such that $X \cap H = \emptyset$.
2. \mathbb{B} has property \mathcal{L} .
3. $G := \pi_1(\mathbb{B}, u_0)$ is subgroup separable.

Before proving Theorem 3.76 we may observe the following:

Remark 3.77. Let \mathbb{B} be a graph of groups. For any $l \in EB$ with $\alpha(l) = \omega(l)$ we modify \mathbb{B} as follows. We add a new vertex u to VB , which cuts l into two pieces l_1 and l_2 . Now define $B_u := B_l =: B_{l_i}$ for $i \in \{1, 2\}$ and let $\alpha_{l_1} = \alpha_l$, $\omega_{l_1} = \alpha_{l_2} = \text{id}$ and $\omega_{l_2} = \omega_l$. Clearly the fundamental group of the resulting graph of groups is isomorphic to $\pi_1(\mathbb{B}, u_0)$. If the underlying graph B of \mathbb{B} is finite, we obtain after finitely many such steps a graph of groups \mathbb{B}' out of \mathbb{B} such that for any two edges $l_1, l_2 \in EB'$ $\alpha(l_1) \neq \alpha(l_2)$ or $\omega(l_1) \neq \omega(l_2)$ and B' has no loops, i.e. $\alpha(l) \neq \omega(l)$ f.a. $l \in EB'$.

Proof of Theorem 3.76: (1) \Rightarrow (2): trivial. For (2) \Rightarrow (3) consider some cover $\tilde{f} : \tilde{\mathbb{A}} \rightarrow \mathbb{B}$ representing some f.g. subgroup U . If U is of finite index there is nothing to show. So assume that U is of infinite index in G . Since U is f.g. there exists some finite subgraph of groups $\tilde{\mathbb{A}}$ of $\tilde{\mathbb{A}}$ such that $\text{Im} \varphi_{\tilde{f}} = \text{Im} \varphi_{\tilde{f}} = U$ for some chosen base point $v_0 \in \tilde{\mathbb{A}}$ and the induced folded morphism $\tilde{f} := \tilde{f}|_{\tilde{\mathbb{A}}}$ (for example $\text{core}(\tilde{\mathbb{A}}, v_0)$). Let $x \in G \setminus U$. Then there exists a reduced $\tilde{\mathbb{A}}$ -path p starting at v_0 and terminating at some $v \in f^{-1}(u_0)$ such that $[\mu_{\tilde{f}}(p) \cdot b] = [\mu_{\tilde{f}}(p)] \cdot [b] = [q] = x$. Clearly one can extend the subgraph of groups $\tilde{\mathbb{A}}$ such that p lies completely in $\tilde{\mathbb{A}}$ without changing the represented subgroup of \tilde{f} . If $v \neq v_0$ the claim follows directly, since $\tilde{\mathbb{A}}$ is assumed to be weakly almost geometric. So let $v = v_0$. Thus $b \notin A_{v_0}$ and since \mathbb{B} has property \mathcal{L} , \tilde{f} is weakly almost geometric realized by some finite-sheeted covering $\mathfrak{g} : \mathbb{C} \rightarrow \mathbb{B}$, such that $b \notin g_{v_0}(C_{v_0})$. So assume that there exists a \mathbb{C} -path p' starting at v_0 such that $\varphi_{\mathfrak{g}}([p']) = [\mu_{\mathfrak{g}}(p')] = x = [\mu_{\mathfrak{g}}(p)] \cdot [b]$ implying $[b] = [\mu_{\mathfrak{g}}(p^{-1})] \cdot [\mu_{\mathfrak{g}}(p')] \in \varphi_{\mathfrak{g}}(\pi_1(\mathbb{C}, v_0))$. Thus $b \in g_{v_0}(C_{v_0})$. A contradiction.

(3) \Rightarrow (1): So let $\tilde{f} : \tilde{\mathbb{A}} \rightarrow \mathbb{B}$ be a folded morphism of finite graphs of groups representing some subgroup $U = \varphi_{\tilde{f}}(\pi_1(\tilde{\mathbb{A}}, v_0))$ and let $X \subseteq G \setminus U$ be a finite subset of elliptic elements. After modifying \mathbb{B} by subdividing some edges in EB in the way as described in Remark 3.77 if necessary, we can assume that B has no loops and that for any pair of edges $e_1, e_2 \in EA$, we have $\alpha(e_1) \neq \alpha(e_2)$ or $\omega(e_1) \neq \omega(e_2)$. Let Y be a maximal subtree of A . For any $v \in VA$ let $\gamma_v := e_1^v, \dots, e_{k_v}^v$ $k_v \in \mathbb{N}$ be the unique path from v_0 to v in Y and $p_v := 1_{A_{v_0}}, e_1^v, \dots, e_{k_v}^v, 1_{A_v}$ be the $\tilde{\mathbb{A}}$ -path corresponding to γ_v with the trivial elements in the corresponding vertex groups. For any pair $v, v' \in VA$ with $v \neq v'$ and $f(v) = f(v')$ it follows $1_G \neq g_{v,v'} := [\mu_{\tilde{f}}(p_v) \cdot \mu_{\tilde{f}}(p_{v'}^{-1})] \in G$. Since G is subgroup separable there exists a finite index subgroup $H_{v,v'}$ containing U such that $g_{v,v'} \notin H_{v,v'}$. Furthermore for any $x \in X$ there exists a finite index subgroup H_x containing U such that $x \notin H_x$. Since A is a finite graph and X a finite set the subgroup

$$H := \bigcap_{v,v'} H_{v,v'} \cap \bigcap_{x \in X} H_x$$

is of finite index in G and contains U . Let $\mathfrak{g} : \mathbb{C} \rightarrow \mathbb{B}$ be a the covering representing H . Thus $H = \varphi_{\mathfrak{g}}(\pi_1(\mathbb{C}, w_0))$ for some $w_0 \in VC$. Since $U \leq H$ there exists a folded morphism $\mathfrak{h} : \tilde{\mathbb{A}} \rightarrow \mathbb{C}$ representing the preimage of U in $\pi_1(\mathbb{C}, w_0)$, i.e. such that $\varphi_{\mathfrak{g}}|_{\varphi_{\mathfrak{h}}(\pi_1(\tilde{\mathbb{A}}, v_0))} \circ \varphi_{\mathfrak{h}} = \varphi_{\tilde{f}}$. So assume that there exists some v, v' in VA with $h(v) = h(v')$. Thus $[\mu_{\mathfrak{h}}(p_v)] \cdot [\mu_{\mathfrak{h}}(p_{v'})]^{-1} \in \pi_1(\mathbb{C}, w_0)$ implying $g_{v,v'} \in H$. A contradiction. The claim follows now since by assumption the map on graph level $h : A \rightarrow C$ must identify two different vertices of VA if $h : A \rightarrow C$ identifies two different edges of EA and $U \leq H \subseteq G \setminus X$. \square

Suppose we are given a graph of group morphism of finite graphs of groups, such that the images of the vertex groups of the graph of groups \mathbb{A} are of finite index in the corresponding vertex groups of \mathbb{B} . Then the following statement shows that $\mathfrak{f} : \mathbb{A} \rightarrow \mathbb{B}$ is almost geometric if and only if the vertex groups of \mathbb{A} are almost geometric.

Theorem 3.78. *Let \mathbb{B} be a (finite) graph of groups having no loops and $u_0 \in VB$. Let $\mathfrak{f} : \mathbb{A} \rightarrow \mathbb{B}$ be a folded morphism of graphs of groups, s.t.*

1. *The underlying graph A of \mathbb{A} is finite and*
2. *$|B_{f(v)} : f_v(A_v)| < \infty$ for any $v \in VA$.*

Then \mathfrak{f} is almost geometric if and only if for any $v \in VA$ the subgroup $f_v(A_v) \leq B_{f(v)}$ is almost geometric.

For the proof of Theorem 3.78, we need the following rules for the construction of graph of group coverings:

Definition 3.79. *Let I be an index set and let $\mathfrak{f}^i : A^i \rightarrow \mathbb{B}$ be a folded morphism and $v_0^i \in VA^i$ for any $i \in I$.*

1. *Two edges $e_1 \in A^i$ and $e_2 \in A^j$ are called α -equivalent and we write $e_1 \sim_{\alpha} e_2$, if*
 - $f^i(e_1) = f^j(e_2) =: l$,
 - $f_{\alpha(e_1)}^i(A_{\alpha(e_1)}) = f_{\alpha(e_2)}^j(A_{\alpha(e_2)}) =: A \leq B_{\alpha(l)}$,
 - $A \cdot g_{e_1}^{\alpha} \cdot \alpha_l(B_l) = A \cdot g_{e_2}^{\alpha} \cdot \alpha_l(B_l)$.
2. *Two edges $e_1 \in A^i$ and $e_2 \in A^j$ are called \sim_{ω} -equivalent and we write $e_1 \sim_{\omega} e_2$ if $e_1^{-1} \sim_{\alpha} e_2^{-1}$.*
3. *We call two edges $e_1 \in A^i$ and $e_2 \in A^j$ \approx -equivalent and we write $e_1 \approx e_2$ if*
 - $f^i(e_1) = f^j(e_2) := l$ and
 - $f_{e_1}^i(A_{e_1}) = f_{e_2}^j(A_{e_2})^b$ for some $b \in B_l$.
4. *An edge $e \in EA^i$, $i \in \{1, 2\}$ is called free, if*
 - $e \notin \text{Core}(A^i, v_0^i)$ and
 - $\text{val}_{A^i}(\alpha(e)) = 1$ or $\text{val}_{A^i}(\omega(e)) = 1$.

Remark 3.80. *By Lemma 3.61 and Lemma 3.63.1, it is an immediate consequence, that \sim_{α} , \sim_{ω} and \approx are equivalence relations on the set $\bigcup_{i \in I} EA^i$. In addition Lemma 3.63.2 implies that if $e_1 \sim_{\alpha} e_2$ or $e_1 \sim_{\omega} e_2$ for $e_1, e_2 \in \bigcup_{i \in I} EA^i$ we already have that $e_1 \approx e_2$. \square*

Let $\mathfrak{f} : \mathbb{A} \rightarrow \mathbb{B}$ be a folded morphism with finite underlying graph A of \mathbb{A} such that \mathfrak{f} is no covering. Then we can add free edges to \mathbb{A} without changing the represented subgroup:

Definition 3.81. Let \mathbb{B} be a graph of groups, $u_0 \in VB$ and $U \leq \pi_1(\mathbb{B}, u_0)$. Furthermore let $\mathfrak{f} : \mathbb{A} \rightarrow \mathbb{B}$ be folded morphism s.t. \mathbb{A} is finite and $\varphi_{\mathfrak{f}}(\pi_1(\mathbb{A}, v_0)) = U$. Obviously there exists a covering $\mathfrak{g} : \mathbb{C} \rightarrow \mathbb{B}$, s.t. \mathbb{A} is a subgraph of groups of \mathbb{C} , $\mathfrak{g}|_{\mathbb{A}} = \mathfrak{f}$ and $U = \varphi_{\mathfrak{g}}(\mathbb{C}, v_0)$. Let $\tilde{\mathbb{A}}$ the subgraph of groups induced by the following subset of edges of \mathbb{C} : $X := EA \cup \{e \in EC \mid \alpha(e) \in VA \vee \omega(e) \in VA\} \subseteq EC$. Hence $E\tilde{\mathbb{A}} = X$ and $V\tilde{\mathbb{A}} = \{v \in VC \mid \exists e \in EC : \alpha(e) = v \vee \omega(e) = v\}$. We call the edges lying in the set $E\tilde{\mathbb{A}} \setminus EA$ free. For any $v \in VA$ and any edge $l \in EB$ with $\alpha(l) = f(v)$ there exists a 1-1 correspondence between the set of edges $\{e \mid e \in E\tilde{\mathbb{A}} \setminus EA \wedge \alpha(e) = v\}$ (the set of edge pairs starting at v and lying in $E\tilde{\mathbb{A}} \setminus EA$) and the double cosets of the form $f_v(A_v) \cdot x \cdot \alpha_l(B_l)$, $x \in B_{f(v)}$ which are not already covered by \mathfrak{f} .

Let $\tilde{\mathfrak{f}} := \mathfrak{g}|_{\tilde{\mathbb{A}}}$. Clearly if $\tilde{\mathbb{A}} = \mathbb{A}$ it follows that \mathfrak{f} is a covering and we deduce that $\mathfrak{f} = \tilde{\mathfrak{f}} = \mathfrak{g}$. In this case the set $E\tilde{\mathbb{A}} - EA$ is empty.

Definition 3.82. Let $\mathfrak{f} : \mathbb{A} \rightarrow \mathbb{B}$ be a folded morphism of graphs of groups, s.t. $VA = \{v\}$, $EA = \emptyset$ and $A_v \leq B_u$ for some $u \in VB$ and $f_v = \text{id}$. Then $\text{core}(\mathbb{A}, v) = \mathbb{A}$ and it follows that $\tilde{\mathbb{A}}$ has the shape of a star, if $\tilde{\mathbb{A}}$ is defined as in Definition 3.81. Moreover for any $e \in E\tilde{\mathbb{A}}$ with $\alpha(e) = v$ holds $\omega_e(A_e) = A_{\omega(e)}$. We call such a "star" the covering piece corresponding to the elliptic subgroup $A_v \leq B_u$.

We will now describe two types of extensions of graphs of groups. A construction step of type A describes a way of gluing two different graphs of groups which correspond to folded graph of group morphisms. A construction step of type B will be the extension of a given graph of groups corresponding to a folded graphs of groups morphism by an HNN-extension.

Construction 3.83 (Extension of graphs of groups). Let I be an index set and let $\mathfrak{f}^i : \mathbb{A}^i \rightarrow \mathbb{B}$ by a folded morphism for any $i \in I$. If there are free edges $e_1 \in EA^i$ and $e_2 \in EA^j$, $i, j \in I$, with $e_1 \approx e_2$ and $\alpha(e_1) \neq \omega(e_2)$, there exists $b \in B_l$ and $l := f^i(e_1) = f^j(e_2)$, s.t. $f_{e_1}^i(A_{e_1})^b = f_{e_2}^j(A_{e_2})$. Since

$$f_{\alpha(e_1)}^i(A_{\alpha(e_1)}) \cdot g_{e_1}^\alpha \cdot \alpha_l(B_l) = f_{\alpha(e_1)}^i(A_{\alpha(e_1)}) \cdot g_{e_1}^\alpha \cdot \alpha_l(b) \cdot \alpha_l(B_l).$$

and

$$f_{\alpha(e_1^{-1})}^i(A_{\alpha(e_1^{-1})}) \cdot g_{e_1^{-1}}^\alpha \cdot \alpha_l(B_l) = f_{\alpha(e_1^{-1})}^j(A_{\alpha(e_1^{-1})}) \cdot g_{e_1^{-1}}^\alpha \cdot \alpha_{l^{-1}}(b) \cdot \alpha_{l^{-1}}(B_l).$$

the elements $g_{e_1}^\alpha$ and $g_{e_2}^\alpha \alpha_l(b)$ cover the same double coset in $B_{\alpha(l)}$ as well as the elements $g_{e_1^{-1}}^\alpha$ and $g_{e_1^{-1}}^\alpha \alpha_{l^{-1}}(b)$ in $B_{\omega(l)} = B_{\alpha(l^{-1})}$.

Therefore it is possible to perform an auxiliary modification of the first type (see Lemma and definition 3.45.1) by replacing $g_{e_1}^\alpha$ by $g_{e_1}^\alpha \alpha_l(b)$, $g_{e_1}^\omega$ by $\omega_l(b)^{-1} g_{e_1}^\omega$, and f_{e_1} by $c_{b^{-1}} \circ f_{e_1} : A_{e_1} \rightarrow B_l, a \mapsto b^{-1} \cdot f_e(a) \cdot b$. Then it follows that $f_{e_1}^i(A_{e_1})$ is replaced by $f_{e_1}^i(A_{e_1})^b$ and that $(g_{e_1^{-1}}^\alpha)$ is replaced by $(g_{e_1^{-1}}^\alpha) \alpha_{l^{-1}}(b)$.

As explained the new g_e^α covers the same double coset as the one before performing this modification, as well as the new $g_{e^{-1}}^\alpha$ will cover the same double coset as the old one. Furthermore notice that \mathfrak{f}^i is still folded and the represented subgroup of \mathfrak{f}^i does not change. We will now modify \mathbb{A}^i and $\mathfrak{f}^i : \mathbb{A}^i \rightarrow \mathbb{B}$ as follows:

- Replace $A_{e_1}^i$ by $A_{e_2}^j$,
- replace $f_{e_1}^i$ by $f_{e_2}^j$,
- replace $\alpha_{e_1}^i$ by $\alpha_{e_1}^i \circ (f_{e_1}^i)^{-1} \circ f_{e_2}^j$,
- replace $f_{e_1}^i$ by $f_{e_1}^i \circ (f_{e_1}^i)^{-1} \circ f_{e_2}^j$,
- replace $A_{w(e_1)}^i$ by $A_{e_2}^j$ and ω_{e_1} by id.

Note that after this process \mathfrak{f}^i is still a well-defined graph of group morphism representing the same subgroup as before since e_1 is free. Now we can glue the two graphs of groups together by identifying the edges e_1 and e_2 . This is possible since they now have the same edge group. By doing this, clearly we also identify their inverse edges e_1^{-1} and e_2^{-1} . We obtain the following graph of groups \mathbb{C} :

1. $VC = VA^1 \setminus \{\alpha(e_1)\} \cup VA^2 \setminus \{\omega(e_2)\}$,
2. $EC = (EA^1 \setminus \{e_1^{\pm 1}\}) \cup (EA^2 \setminus \{e_2^{\pm 1}\}) \cup \{\mathfrak{e}\}$ with $\alpha(\mathfrak{e}) = \alpha(e_1)$ and $\omega(\mathfrak{e}) = \omega(e_2)$.
3. There are embeddings of graphs of groups $\mathfrak{g}^i : \mathbb{A}^i \hookrightarrow \mathbb{C}$ and $\mathfrak{g}^j : \mathbb{A}^j \hookrightarrow \mathbb{C}$, s.t. on underlying graph level, the following holds:
 - $g^i(e) \neq g^j(e')$ f.a. $e \in EA^i \setminus \{e_1\}$ and $e' \in EA^j \setminus \{e_2\}$,
 - $\mathfrak{e} = g^i(e_1) = g^j(e_2)$
4. There are subgraphs of groups of \mathbb{C} associated to $A^i \setminus \{e_1\}$ and $A^j \setminus \{e_2\}$, respectively and these subgraphs of groups can be identified with the corresponding subgraphs of groups in \mathbb{A}^i and \mathbb{A}^j , respectively, that means f.a. $x \in VA^i \cup EA^i$ we have $A_x = C_{g^i(x)}$ as well as for any $x \in VA^j \cup EA^j$ we have $A_x = C_{g^j(x)}$. In particular $C_{\mathfrak{e}} = A_{e_1}^i = A_{e_2}^j$.

Define now $\mathfrak{g} : \mathbb{C} \rightarrow \mathbb{B}$ as follows

- $\mathfrak{g}|_{\mathbb{A}^i \setminus \{e_1\}} := \mathfrak{f}^i$ and $\mathfrak{g}|_{\mathbb{A}^j \setminus \{e_2\}} := \mathfrak{f}^j$,
- $g(\mathfrak{e}) := f^i(e_1) = f^j(e_2)$,
- $g_{\mathfrak{e}} := f_{e_1}^i = f_{e_2}^j$,
- $g_{\mathfrak{e}}^\alpha := g_{e_1}^\alpha$ and $g_{\mathfrak{e}}^\omega := g_{e_2}^\omega$,
- $\alpha_{\mathfrak{e}} := \alpha_{e_1}$ and $\omega_{\mathfrak{e}} := \omega_{e_2}$.

Clearly we have that \mathfrak{g} is folded, since \mathfrak{f}^1 and \mathfrak{f}^2 are folded.

1. If $i \neq j$, then it follows that the number of free edge pairs in A^i and A^j decreases by 1. Furthermore \mathfrak{g} represents now a subgroup, which contains either the represented subgroup of \mathfrak{f}^i or the subgroup represented by \mathfrak{f}^j . Clearly this only depends on the choice of the base vertex and we have that both subgroups are at least conjugate into the subgroup represented by \mathfrak{g} . We call this approach a construction step of type A.

2. If $i = j$ the previous process produces nothing else than a new HNN-extension and the obtained graph of groups \mathbb{C} has exactly two free edge pairs less than $\mathbb{A}^i = \mathbb{A}^j$. Clearly the base vertex can be chosen such that the subgroup represented by $\mathfrak{f}^i = \mathfrak{f}^j$ is contained in the subgroup represented by \mathfrak{g} . We call this approach a construction step of type B.

Proof of the Theorem: Note that the implication " \Rightarrow " is trivial. For " \Leftarrow " let $\mathfrak{f} : \mathbb{A} \rightarrow \mathbb{B}$ be folded, s.t. A is finite and $|B_{f(v)} : f_v(A_v)| < \infty$ f.a. $v \in VA$. Since \mathbb{B} has no loops, we have that $\alpha(e) \neq \omega(e)$ f.a. $e \in EB$. We will prove the assumption by induction over the finite number of vertices in A .

So let $|VA| = 1$ and $VA = \{v_0\}$. Since \mathbb{B} has no loops we have that $\varphi_f(\pi_1(\mathbb{A}, v_0)) = [f_{v_0}(A_{v_0})] \leq \pi_1(\mathbb{B}, u_0)$. Thus the claim is trivial.

So assume that the assumption is true for any folded morphism of graphs of groups $\mathfrak{f} : \mathbb{A} \rightarrow \mathbb{B}$ with $|VA| < k$. Let $|VA| = k > 1$. If \mathfrak{f} is already a covering there is nothing to show. So assume the contrary and choose $E \subseteq EA$ with $e^{-1} \notin E$ if $e \in E$, s.t. after removing any edge pair $\{e, e^{-1}\}$ for $e \in E$ the underlying graph A of \mathbb{A} decomposes into two connected components A^1 and A^2 . W.l.o.g. we assume that for any $e \in E$ we have that $\alpha(e) \in A^1$ and $\omega(e) \in A^2$.

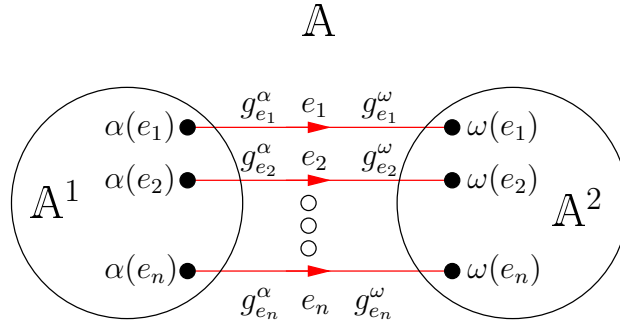

Figure 3: The two subgraphs of groups \mathbb{A}^1 and \mathbb{A}^2 of \mathbb{A} and the set of edges $\{e_1, \dots, e_n\} = E$, $n \in \mathbb{N}$.

The folded morphism \mathfrak{f} induces two folded morphisms $\mathfrak{f}^i : \mathbb{A}^i \rightarrow \mathbb{B}$ by setting $\mathfrak{f}^i := \mathfrak{f}|_{\mathbb{A}^i}$ for $i \in \{1, 2\}$. Clearly we have now $VA^i < k$ for $i \in \{1, 2\}$. Therefore by induction hypothesis \mathfrak{f}^i is almost geometric realized by some covering of graphs of groups $\mathfrak{h}^i : \mathbb{C}^i \rightarrow \mathbb{B}$ for any $i \in \{1, 2\}$. We proceed now as follows:

1. F.a. $e \in E$ we remove the pair of edges $t, t^{-1} \in EC^1$ with
 - $\alpha(t) = \alpha(e)$,
 - $t_\alpha \sim e$.
2. F.a. $e \in E$ we remove the pair of edges $s, s^{-1} \in EC^2$ with
 - $\omega(s) = \omega(e)$,
 - $s \sim_\omega e$.
3. After doing this for any $e \in E$, we observe that in general the underlying graphs C^1 and C^2 are not connected anymore. So let $C_1^i, \dots, C_{m_i}^i$ be the set of connected components of C^i for $i \in \{1, 2\}$.

Clearly there are folded morphisms $\mathfrak{h}_j^i : \mathbb{C}_j^i \rightarrow \mathbb{B}$ for all $i \in \{1, 2\}$ and $j \in \{1, \dots, m_i\}$. For any $i \in \{1, 2\}$ and any $j \in \{1, \dots, m_i\}$ define $\widetilde{\mathbb{C}}_j^i$ and $\widetilde{\mathfrak{h}}_j^i : \widetilde{\mathbb{C}}_j^i \rightarrow \mathbb{B}$ as in 3.81. Let \widetilde{C}^i be the (in general not connected) graph with $V\widetilde{C}^i = \bigcup_{j \in \{1, \dots, m_i\}} V\widetilde{C}_j^i$ and $E\widetilde{C}^i = \bigcup_{j \in \{1, \dots, m_i\}} E\widetilde{C}_j^i$ for $i \in \{1, 2\}$. Similarly let C^i be the union of the graphs C_j^i for $i \in \{1, 2\}$. Then it follows that C^i is a subgraph of \widetilde{C}^i .

4. Then for any removed edge t (associated to some $e \in E$) we have edges $t^1, t^2 \in E\widetilde{C}^1$ with

- $\alpha(t^1) = \alpha(t) = \alpha(e)$ and $\omega(t^1) \in V\widetilde{C}^1 \setminus VC^1$,
- $t^1 \underset{\alpha}{\sim} t \underset{\alpha}{\sim} e$,
- $\alpha(t^2) \in V\widetilde{C}^1 \setminus VC^1$ and $\omega(t^2) = \omega(t)$,
- $t^2 \underset{\omega}{\sim} t$.

And for any removed edge s (associated to some $e \in E$) we find edges $s^1, s^2 \in E\widetilde{C}^2$ satisfying

- $\alpha(s^1) = \alpha(s)$ and $\omega(s^1) \in V\widetilde{C}^2 \setminus VC^2$,
- $s^1 \underset{\alpha}{\sim} s$,
- $\alpha(s^2) \in V\widetilde{C}_i^2 \setminus VC_i^2$ and $\omega(s^2) = \omega(s) = \omega(e)$,
- $s^2 \underset{\omega}{\sim} s \underset{\omega}{\sim} e$,

s.t. by identifying t^1 and t^2 we would create an edge \mathfrak{t} s.t.

- $\mathfrak{t} \underset{\omega}{\sim} t$ and $\mathfrak{t} \underset{\alpha}{\sim} t$,
- $\alpha(\mathfrak{t}) = \alpha(t)$ and $\omega(\mathfrak{t}) = \omega(t)$.

And by identifying the edges s^1 and s^2 we would create an edge \mathfrak{s} s.t.

- $\mathfrak{s} \underset{\omega}{\sim} s$ und $\mathfrak{s} \underset{\alpha}{\sim} s$,
- $\alpha(\mathfrak{s}) = \alpha(s)$ und $\omega(\mathfrak{s}) = \omega(s)$.

But since obviously (see Remark 3.80) we have that $t^1 \approx s^2$ and $s^1 \approx t^2$ we are allowed to perform another identification: We obtain by identifying $t^1 \approx s^2$ an edge \mathfrak{e} satisfying

- $\mathfrak{e} \underset{\omega}{\sim} e$ and $\mathfrak{e} \underset{\alpha}{\sim} e$,
- $\alpha(\mathfrak{e}) = \alpha(e)$ and $\omega(\mathfrak{e}) = \omega(e)$.

In the same way we create a new edge by identifying $s^1 \approx t^2$ and after finitely many identifications of this type, we receive a finite set of finite graphs of groups $D := \{\mathbb{D}^1, \dots, \mathbb{D}^m\}$, $m \in \mathbb{N}$ and associated finite-sheeted coverings of graphs of groups $\mathfrak{g}_i : \widetilde{\mathbb{D}}^i \rightarrow \mathbb{B}$, $i \in \{1, \dots, m\}$ with the property that the underlying graphs D^1, \dots, D^m were obtained by identifying the pairs $t^1 \approx s^2$ and $s^1 \approx t^2$ in the previously described way for any $e \in E$.

In particular there exists a graph of groups $\mathbb{C} \in D$ with underlying graph C and associated finite-sheeted covering $\mathfrak{g} : \mathbb{C} \rightarrow \mathbb{B}$, s.t. $\mathfrak{e} \in EC$ f.a. (associated) $e \in E$. Furthermore it follows that C must contain the subgraph A' defined by $VA' := VA^1 \cup VA^2$ and $EA' := (EA^1 \cup EA^2) \cup \{\mathfrak{e} | e \in E\}$.

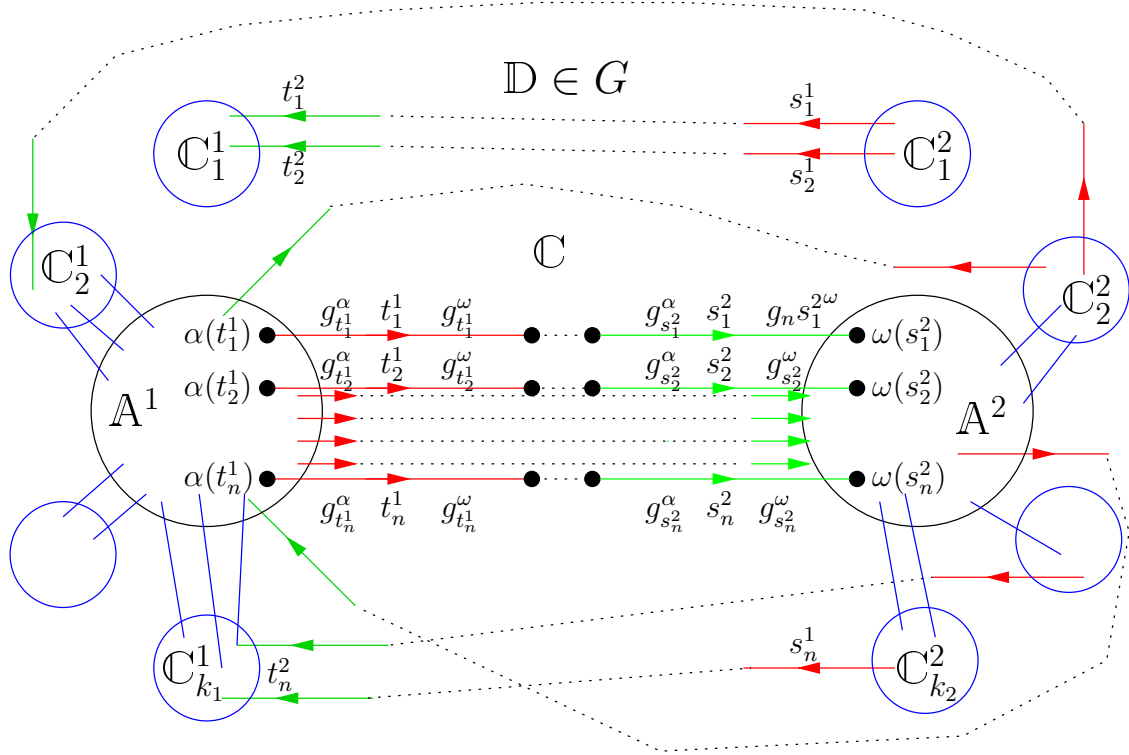

Figure 4: The resulting graph of groups \mathbb{C} containing A' .

Clearly it follows by construction that the associated subgraph of groups A' is isomorphic to A and as $\mathfrak{e} \sim_\omega e$ and $\mathfrak{e}_\alpha \sim e$ f.a. $e \in E$ we have that \mathfrak{f} and $\mathfrak{g}|_{A'}$ are representing the same subgroup. We conclude that A is almost geometric and that $\varphi_{\mathfrak{f}}(\pi_1(A, v_0))$ is a subgroup of $\varphi_{\mathfrak{g}}(\pi_1(\mathbb{C}, v_0)) \leq \pi_1(\mathbb{B}, g(v_0))$ s.t. $|\pi_1(\mathbb{B}, g(v_0)) : \varphi_{\mathfrak{g}}(\pi_1(\mathbb{C}, v_0))| < \infty$. \square

3.5.3 Covers of finite graph of finite groups

In [21] the authors proved the following:

Theorem 3.84. *Let G be a f.g. virtually free group. Then G splits as a finite graph of finite groups.* \square

Although it is a well-known fact that the converse is also true, i.e. that fundamental groups of finite graphs of finite groups are virtually free, we will give an easy proof for this statement using covering theory of graphs of groups. Moreover we will give a rank formula for free subgroups of finite index of fundamental groups of finite graphs of finite groups as a function of their indices and the orders of the vertex groups and edge groups of the given graph of groups.

Note that the following statement is obvious:

Remark 3.85. Let $\mathfrak{f} : \mathbb{A} \rightarrow \mathbb{B}$ be a cover of finite graphs of finite groups representing some subgroup F . Then F is a free subgroup if and only if $A_v = \{1_{A_v}\}$ for any $v \in VA$. □

Using this observation the following Lemma is an immediate consequence of Theorem 3.42:

Lemma 3.86. Let \mathbb{B} be a finite graph of finite groups and $\mathfrak{f} : \mathbb{A} \rightarrow \mathbb{B}$ be a cover representing some free group F of finite index in $G = \pi_1(\mathbb{B}, u_0)$. Then for any $l \in EB$ holds:

1. $|G : F| = \sum_{v \in f^{-1}(\alpha(l))} |B_{f(v)} : f_v(A_v)| = \sum_{v \in f^{-1}(\alpha(l))} |B_{f(v)}| = |f^{-1}(\alpha(l))| \cdot |B_{\alpha(l)}|$.
2. $|f^{-1}(\alpha(l))| = \frac{f^{-1}(l)}{|B_{\alpha(l)} : B_l|} = \frac{f^{-1}(l) \cdot |B_l|}{|B_{\alpha(l)}|}$.
3. $|G : F| = \frac{f^{-1}(l) \cdot |B_l|}{|B_{\alpha(l)}|} \cdot |B_{\alpha(l)}| = f^{-1}(l) \cdot |B_l|$.

Proof: The first assertion follows directly by Theorem 3.42. For the second statement we can apply Theorem 3.68. Then it follows for any $v \in f^{-1}(\alpha(l))$:

$$B_{\alpha(l)} = \bigcup_{e \in f^{-1}(l)_v} f_v(A_v) \cdot g_e^\alpha \cdot \alpha_l(B_l) = \bigcup_{e \in f^{-1}(l)_v} g_e^\alpha \cdot \alpha_l(B_l).$$

Hence $|f_l^{-1}(v)| = |B_{\alpha(l)} : B_l|$ for any $v \in f^{-1}(\alpha(l))$. Since the third assertion follows by the first in combination with the second we are done. □

The following is an immediate consequence:

Corollary 3.87. Let \mathbb{B} be a finite graph of finite groups and $\mathfrak{f} : \mathbb{A} \rightarrow \mathbb{B}$ be a cover representing some free group F of finite index in $G = \pi_1(\mathbb{B}, u_0)$. Then there exists $n \in \mathbb{N}$ such that $|G : F| = n \cdot \text{lcm}(B_u)_{u \in VB}$. □

Note that by Theorem 3.84 any f.g. virtually free group splits as a finite graph of finite groups. Therefore the following statement provides us a rank formula for free subgroups of finite index in f.g. virtually free groups:

Corollary 3.88. Let \mathbb{B} be a finite graph of finite groups and let $F \leq G = \pi_1(\mathbb{B}, u_0)$ be a free subgroup of finite index in G . Then

$$\text{rank}(F) = \frac{1}{2} \cdot \sum_{l \in EB} \frac{|G : F|}{|B_l|} - \sum_{u \in EB} \frac{|G : F|}{|B_u|} + 1.$$

Proof: Let $\mathfrak{f} : \mathbb{A} \rightarrow \mathbb{B}$ be a cover representing F . Clearly $\text{rank}(F) = \frac{1}{2}EA - VA + 1$. By Lemma 3.86.3 it follows that $f^{-1}(l) = \frac{|G:F|}{|B_l|}$ for any $l \in EB$. Thus we deduce that $EA = \sum_{l \in EB} \frac{|G:F|}{|B_l|}$. Now the claim follows since $f^{-1}(u) = \frac{|G:F|}{|B_u|}$ for any $u \in VB$ by Lemma 3.86.1 and therefore $VA = \sum_{u \in EB} \frac{|G:F|}{|B_u|}$. □

Suppose we are given a f.g. virtually free group $G = \pi_1(\mathbb{B}, u_0)$ for some finite graph of finite groups \mathbb{B} and $u_0 \in VB$. Then the following statement shows for which given natural number $k \in \mathbb{N}$ there exists some finite index subgroup $F \leq G$ of index k .

Theorem 3.89. *Let \mathbb{B} be a finite graph of finite groups. Then for any $n \in \mathbb{N}$ there exists a free group F of finite index in $G = \pi_1(\mathbb{B}, u_0)$ such that $|G : F| = n \cdot \text{lcm}(B_u)_{u \in VB}$.*

Proof: Let $u \in VB$. Then any covering piece corresponding to the trivial subgroup $\{1_{B_u}\}$ (see Definition 3.82) has exactly $\frac{|B_u|}{|B_l|}$ free edges for any $l \in EB$ satisfying $\alpha(l) = u$, and all of these edges are equivalent (see Construction 3.83). Moreover for any $l \in EB$ it follows that any edge starting at some covering piece corresponding to $\{1_{B_{\alpha(l)}}\}$ is equivalent to any edge terminating at some covering piece corresponding to $\{1_{B_{\omega(l)}}\}$. So let $n \in \mathbb{N}$. For any $u' \in VB$ take exactly $n \cdot \frac{\text{lcm}(B_u)_{u \in VB}}{B_{u'}}$ copies of the covering piece corresponding to the subgroup $\{1_{B_{u'}}\}$. Then for any $l \in EB$ it follows that any covering piece corresponding to $\{1_{B_{\alpha(l)}}\}$, has exactly $\frac{|B_{\alpha(l)}|}{|B_l|}$ free preimages of the edge l . Thus for any $l \in EB$ we get exactly

$$n \cdot \frac{\text{lcm}(B_u)_{u \in VB}}{|B_{\alpha(l)}|} \cdot \frac{|B_{\alpha(l)}|}{|B_l|} = n \cdot \frac{\text{lcm}(B_u)_{u \in VB}}{B_l}$$

free preimages of the edge l starting at some covering piece corresponding to $\{1_{B_{\alpha(l)}}\} \leq B_{\alpha(l)}$. Since the same holds for l^{-1} we deduce that the number of free preimages of l terminating at some covering piece corresponding to $\{1_{B_{\omega(l)}}\} \leq B_{\omega(l)}$ is as well $\frac{\text{lcm}(B_u)_{u \in VB}}{B_l}$. Clearly one can identify any free edge originating at some covering piece corresponding to $\{1_{B_{\alpha(l)}}\}$ with some free edge terminating at some covering piece corresponding to $\{1_{B_{\omega(l)}}\}$. And since for any $l \in EB$ the number of preimages of l originating at some covering piece corresponding to $\{1_{B_{\alpha(l)}}\}$ coincides with the number of edges terminating at some covering piece corresponding to $\{1_{B_{\omega(l)}}\}$ after finitely many construction steps as described in Construction 3.83, we receive a finite-sheeted cover $\mathfrak{f} : \mathbb{A} \rightarrow \mathbb{B}$ representing some finite index subgroup of U of G and by Remark 3.85 U is free. Moreover since for any $u \in UB$ we used exactly $n \cdot \frac{\text{lcm}(B_u)_{u \in VB}}{B_u}$ copies of the covering piece corresponding to the subgroup $\{1_{B_u}\}$ to create this cover, the represented subgroup has the desired index by Theorem 3.42. \square

Combining this with Theorem 3.84 leads to:

Theorem 3.90. *A f.g. group G is virtually free if and only if G splits as a finite graph of finite groups.* \square

Moreover we deduce the following immediate consequence of Theorem 3.89:

Corollary 3.91. *Let \mathbb{B} be a finite graph of finite groups. Let $F \leq G = \pi_1(\mathbb{B}, u_0)$ be a free subgroup of minimal index in G . Then the following holds:*

1. $|G : F| = \text{lcm}(B_u)_{u \in VB}$.
2. $\text{rank}(F) = \frac{1}{2} \cdot \sum_{l \in EB} \frac{\text{lcm}(B_u)_{u \in VB}}{|B_l|} - \sum_{u \in EB} \frac{\text{lcm}(B_u)_{u \in VB}}{|B_u|} + 1$. \square

We close this chapter with showing that any f.g. subgroup of the fundamental group of a finite graph of finite groups is almost geometric (see Definition 3.75).

Theorem 3.92. *Let \mathbb{B} be a finite graph of finite groups. Then the fundamental group $G = \pi_1(\mathbb{B}, u_0)$, $u_0 \in VB$, of \mathbb{B} is subgroup separable if and only if any finitely generated subgroup of G is almost geometric.*

Proof: Applying Theorem 3.76 it follows that $\pi_1(\mathbb{B}, u_0)$ is subgroup separable if any f.g. subgroup of $\pi_1(\mathbb{B}, u_0)$ is almost geometric. Conversely Let $B'_u \leq B_u$ for some $u \in VB$. We may assume that $u_0 = u$. Let $X := B_{u_0} \setminus B'_u$. Since B_{u_0} is a finite group, we have that X is a finite set. Since G is assumed to be subgroup separable we find for any $x \in X$ a normal finite index subgroup $N_x \trianglelefteq G$ and a homomorphism from $\varphi_x : G \rightarrow G/N_x$, such that $\varphi_x(x) \notin \varphi_x(B'_u)$. Clearly for any $x \in X$ we have that $D_x = B'_u \cdot N_x$ is a finite index subgroup of G containing B'_u , such that $x \notin D_x$. Consider the subgroup $D := \bigcap_{x \in X} D_x$ of G . Clearly D is of finite index in G since X is a finite set and it follows that $x \notin D \leq D_x$ for any $x \in X$. Furthermore there exists a covering $\mathfrak{f} : \mathbb{A} \rightarrow \mathbb{B}$ representing D , i.e. $D = \varphi_{\mathfrak{f}}(\pi_1(\mathbb{A}, v_0))$ for some $v_0 \in VA$. Thus, since u equals the base vertex and $x \notin D = \varphi_{\mathfrak{f}}(\pi_1(\mathbb{A}, v_0))$, we deduce that $B'_u = f_{v_0}(A_{v_0})$ implying that B'_u is almost geometric. Thus we proved that any elliptic subgroup is almost geometric. Therefore the claim follows by Theorem 3.78. \square

In [17] M. Hall showed that free groups are subgroup separable. Furthermore in [36] it is proven by P. Scott that the subgroup separability is inherited by subgroups and finite extensions. Thus we deduce that the following is true:

Theorem 3.93. *Let G be a virtually free group. Then G is subgroup separable.* \square

By applying Theorem 3.90 combined with 3.92 we conclude:

Corollary 3.94. *Any f.g. subgroup of a finite graph of finite groups is almost geometric.* \square

4 Towers of (k, C) -acylindrical stars of groups and the Subgroup Separability

4.1 (k, C) -acylindrical graphs of groups

In [45] Henry Wilton proved that Limit Groups are subgroup separable. For doing this he used that the subgroup separability is inherited by subgroups and that any Limit Group embeds into a so called ICE-tower over a free group. In this chapter we will adopt some ideas of this work in order to prove that some special kind of "tower extensions" of f.g. virtually free groups are subgroup separable. To warm up, we start with the following well-known facts about group actions on trees.

Definition 4.1. *Let \mathbb{B} be a graph of groups and $k, C \in \mathbb{N}$. We call \mathbb{B} (k, C) -acylindrical, if the action of $G = \pi_1(\mathbb{B}, u_0)$ on $\widetilde{(\mathbb{B}, u_0)}$ is (k, C) -acylindrical, i.e. if for any two vertices $v, w \in V(\widetilde{(\mathbb{B}, u_0)})$ satisfying that the distance of $v, w \in V(\widetilde{(\mathbb{B}, u_0)})$ is greater than k , we write $d(v, w) > k$, the stabilizer of the segment $[v, w]$ in $\widetilde{(\mathbb{B}, u_0)}$ is of order at most C in G .*

Lemma 4.2. *Let $k, C \in \mathbb{N}$, \mathbb{B} be a finite (k, C) -acylindrical graph of groups and let $\gamma \in G$ be a hyperbolic element. Then the following holds:*

1. *The setwise stabilizer of $\text{Axis}(\gamma)$,*

$$\text{Stab}_G(\text{Axis}(\gamma)) := \{g \in G : g \cdot v \in \text{Axis}(\gamma) \text{ f.a. } v \in \text{Axis}(\gamma)\}$$

is virtually cyclic.

2. *Let $\gamma' \in A = \text{Stab}_G(\text{Axis}(\gamma))$ be an infinite order element. Then γ' acts hyperbolically on $\text{Axis}(\gamma)$ and $\langle \gamma' \rangle$ is of finite index in A .*

Proof:

1. Assume that the action of $G = \pi_1(\mathbb{B}, u_0)$ on $\widetilde{(\mathbb{B}, u_0)}$ is (k, C) -acylindrical. Clearly $A := \text{Stab}_G(\text{Axis}(\gamma))$ acts on $\text{Axis}(\gamma)$ and therefore there exists a homomorphism $\Phi : \text{Stab}_G(\text{Axis}(\gamma)) \rightarrow D_\infty$ as $\text{Aut}(\text{Axis}(\gamma)) \cong D_\infty$. Since the action is (k, C) -acylindrical, $\ker(\Phi)$ must be a finite subgroup of A . Thus A is finite, finite-by-infinite cyclic or finite-by-infinite dihedral and therefore virtually cyclic.
2. Let $\gamma' \in A$ be an infinite order element. Since $\ker(\Phi)$ is finite we deduce that $\Phi(\langle \gamma' \rangle)$ is infinite cyclic and therefore of finite index in $D_\infty = \mathbb{Z}_2 \rtimes \mathbb{Z}$. Clearly this implies that γ' acts hyperbolically and that $|A : \langle \gamma' \rangle| < \infty$. \square

Lemma 4.3. *Let \mathbb{B} be a finite (k, C) -acylindrical graph of groups for some $k, C \in \mathbb{N}$. Moreover let γ, γ' be two hyperbolic elements and $A = \text{Stab}_G(\text{Axis}(\gamma))$ and $A' = \text{Stab}_G(\text{Axis}(\gamma'))$. Then the following conditions are equivalent:*

- (1) $\text{Axis}(\gamma) \cap \text{Axis}(\gamma')$ is an infinite ray in Γ .
- (2) $|A \cap A'| = \infty$.
- (3) $\text{Axis}(\gamma) = \text{Axis}(\gamma')$.
- (4) $A = A'$.

Proof:

- (1) \Rightarrow (2): Assume that the lines $\text{Axis}(\gamma)$ and $\text{Axis}(\gamma')$ intersect in an infinite ray, say R . Hence there are $z, w \in \mathbb{Z}$ such that $(\gamma^z(\gamma')^w) \cdot v = v$ for any $v \in R$ and it follows by Lemma 4.2 that $\gamma^z(\gamma')^w \in \ker(\Phi)$, as R is an infinite ray. Thus $(\gamma')^w \in A$ and therefore $|A \cap A'| = \infty$.
- (2) \Rightarrow (3): Assume that $X = A \cap A'$ is an infinite subgroup of G . Then $X \cap \langle \gamma \rangle \cap \langle \gamma' \rangle$ is of finite index in X . Hence $X \cap \langle \gamma \rangle \cap \langle \gamma' \rangle$ is as well an infinite subgroup of G . Thus there exists some $m \in \mathbb{N}$ such that $\gamma^m \in \langle \gamma' \rangle$ implying that $\text{Axis}(\gamma) = \text{Axis}(\gamma^m) = \text{Axis}(\gamma')$.
- (3) \Rightarrow (4): Clearly if $\text{Axis}(\gamma) = \text{Axis}(\gamma')$, we have that $A' = A$ by definition of A and A' .
- (4) \Rightarrow (1): If $A = A'$ it follows that there exists $m \in \mathbb{N}$ satisfying $\gamma^m \in \langle \gamma' \rangle$ since $\langle \gamma \rangle \cap \langle \gamma' \rangle$ is of finite index in $A = A'$ and we conclude $\text{Axis}(\gamma) = \text{Axis}(\gamma^m) = \text{Axis}(\gamma')$. □

Corollary 4.4. *Let \mathbb{B} be a finite graph of groups such that the action of $G = \pi_1(\mathbb{B}, u_0)$ on (\mathbb{B}, u_0) is (k, C) -acylindrical for some $k, C \in \mathbb{N}$. Let $\gamma \in G$ be hyperbolic and let $|A \cap A^g| = \infty$ for $A = \text{Stab}_G(\text{Axis}(\gamma))$ and some $g \in G$. Then $g \in A$ and therefore $A = A^g$. Moreover there exists some $m \in \mathbb{N}$ and some $\epsilon \in \{+1, -1\}$ with $(\gamma^m)^g = \gamma^{\epsilon m}$.*

Proof: Clearly $A^g = \text{Stab}_G(\text{Axis}(\gamma^g)) = \text{Stab}_G(g^{-1}\text{Axis}(\gamma))$. By Lemma 4.3 applied to γ and $\gamma' = \gamma^g$ it follows that $\text{Axis}(\gamma) = g^{-1}\text{Axis}(\gamma)$ and therefore $g \in A$. In particular $A = A^g$. Note that the translation length of γ equals the translation length of γ^g on $g^{-1}\text{Axis}(\gamma) = \text{Axis}(\gamma)$. Thus it follows that for any $n \in \mathbb{N}$ either $(\gamma^g)^n \gamma^{-n} \cdot v = v$ or $(\gamma^g)^n \gamma^n \cdot v = v$ for any vertex $v \in V\text{Axis}(\gamma)$. Hence there exists $\epsilon \in \{+1, -1\}$ such that $g^{-1}\gamma^n g \gamma^{\epsilon n} \in \ker(\Phi)$ for any $n \in \mathbb{N}$ if $\Phi : \text{Stab}_G(\text{Axis}(\gamma)) \rightarrow D_\infty$ is the naturally given homomorphism. We distinguish two cases:

1. Assume that $g^{-1}\gamma^n g \gamma^{-n} \in \ker(\Phi)$ for any $n \in \mathbb{N}$. Since $\ker(\Phi)$ is finite by (k, C) -acylindricity it follows that there exists $n, l \in \mathbb{N}$, $l < n$, such that $g^{-1}\gamma^n g \gamma^{-n} = x = g^{-1}\gamma^l g \gamma^{-l}$ for some $x \in \ker(\Phi)$. Thus $g^{-1}\gamma^n g \gamma^{-n} \gamma^l g^{-1} \gamma^{-l} g = 1$ implying that for $m = n - l$ we have $[\gamma^m, g] = \gamma^{-m} g^{-1} \gamma^m g = 1$.
2. Assume that $g^{-1}\gamma^n g \gamma^n \in \ker(\Phi)$ for any $n \in \mathbb{N}$. Recall that $\gamma^g \in A^g = A$ and that $\langle \gamma \rangle$ is of finite index in A . Thus it follows for $m = |A : \langle \gamma \rangle|!$ that $(\gamma^g)^m = (\gamma^m)^g \in \langle \gamma \rangle$. By comparing translation lengths it follows that $(\gamma^m)^g = \gamma^{-m}$. □

Corollary 4.5. *Let \mathbb{B} be a finite graph of groups such that the action of $G = \pi_1(\mathbb{B}, u_0)$ on (\mathbb{B}, u_0) is (k, C) -acylindrical for some $k, C \in \mathbb{N}$. Let A be a virtually cyclic subgroup of G . Moreover assume that A is maximal virtually abelian and that A contains some hyperbolic element $\gamma \in G$. Then $A = \text{Stab}_G(\text{Axis}(\gamma))$.*

Proof: Since A is virtually cyclic, A contains some normal cyclic subgroup of finite index, say $\langle \gamma' \rangle$. Hence the subgroup $X = \langle \gamma \rangle \cap \langle \gamma' \rangle$ is cyclic and of finite index in $\langle \gamma \rangle$. Moreover X is of finite index in $\langle \gamma' \rangle$ and therefore of finite index in A . Thus there exists $d \in \mathbb{N}$ such that $\langle \gamma^d \rangle$ is normal in A . Hence for any $g \in A$ it follows $g^{-1}\text{Axis}(\gamma^d) = \text{Axis}(\gamma^d) = \text{Axis}(\gamma)$ and therefore $g \in \text{Stab}_G(\text{Axis}(\gamma))$ implying that $A \leq \text{Stab}_G(\text{Axis}(\gamma))$. Since the action is (k, C) -acylindrical it follows that $\text{Stab}_G(\text{Axis}(\gamma))$ is virtually cyclic. Thus $A = \text{Stab}_G(\text{Axis}(\gamma))$ as A is maximal virtually abelian. □

Definition 4.6. Let $\mathfrak{f} : \mathbb{A} \rightarrow \mathbb{B}$ be a cover representing some f.g. subgroup $U = \varphi_{\mathfrak{f}}(\pi_1(\mathbb{A}, v_0))$ of $G = \pi_1(\mathbb{B}, u_0)$. Let $\gamma \in G$ be hyperbolic and let q be a reduced \mathbb{B} -path such that $[q] = \gamma$. Note that $f_{\mathfrak{f}} : (\mathbb{A}, v_0) \rightarrow (\mathbb{B}, u_0)$ is an isomorphism of trees, since \mathfrak{f} is a cover. Let $\mathfrak{h} : (\mathbb{A}, v_0) \rightarrow \mathbb{A}$ be the universal graphs of groups cover. Then we define $\text{Axis}_{\mathbb{A}}^{v_0}(\gamma)$ to be the image of $\text{Axis}(\gamma)$ under the given morphism of graphs $h \circ f_{\mathfrak{f}}^{-1} : (\mathbb{B}, u_0) \rightarrow \mathbb{A}$.

Remark and Definition 4.7. Let $\mathfrak{f} : \mathbb{A} \rightarrow \mathbb{B}$ be a cover representing some f.g. subgroup $U = \varphi_{\mathfrak{f}}(\pi_1(\mathbb{A}, v_0))$ of $G = \pi_1(\mathbb{B}, u_0)$. Let $\gamma \in G$ be hyperbolic and let q be a reduced \mathbb{B} -path such that $[q] = \gamma$. Let k be the translation length of γ with respect to the action of γ on (\mathbb{B}, u_0) . Then there exist reduced \mathbb{B} -paths u and q_{γ} such that q_{γ} is of length k and $[q] = [u] \cdot [q_{\gamma}] \cdot [u]^{-1}$. Then for any $z \in \mathbb{Z}$ there exists a reduced \mathbb{A} -path $p_{\gamma}^z = a_0^z, e_1^z, \dots, e_{n_z}^z, a_{n_z}^z$ with $a_{n_z}^z = 1_{A_{\omega(p_{\gamma}^z)}}$ such that $[\mu(p_{\gamma}^z)] \cdot [b] = [u] \cdot [q_{\gamma}]^z$ for some $b \in B_{\omega(u \cdot q_{\gamma})}$. We call p_{γ}^z a reduced preimage of $u \cdot q_{\gamma}^z$ starting at v_0 . Then it follows for any $z \in \mathbb{Z} \setminus \{0\}$ that $\omega(p_{\gamma}^z) \in V\text{Axis}(\gamma)$. \square

Definition 4.8. Let \mathbb{B} be a finite graph of groups. We call a hyperbolic element $\gamma \in G = \pi_1(\mathbb{B}, u_0)$ proper if for any cover $\mathfrak{f} : \mathbb{A} \rightarrow \mathbb{B}$, representing some f.g. subgroup U of G , $\text{Axis}_{\mathbb{A}}^{v_0}(\gamma)$ is a finite subgraph of \mathbb{A} if and only if $\langle \gamma^d \rangle \in U$ for some $d \in \mathbb{N}$.

Lemma 4.9. Let \mathbb{B} be a finite graph of finite groups. Then any hyperbolic element $\gamma \in G = \pi_1(\mathbb{B}, u_0)$ is proper.

Proof: Let $\mathfrak{f} : \mathbb{A} \rightarrow \mathbb{B}$ be a cover. If U is a finite index subgroup of G the claim is obvious, since in this case \mathbb{A} is a finite graph and $U \cap \langle \gamma \rangle$ is of finite index in $\langle \gamma \rangle$. Thus assume that $U := \varphi_{\mathfrak{f}}(\pi_1(\mathbb{A}, v_0))$ has infinite index in G and let q be a reduced \mathbb{B} -path with $[q] = \gamma \in G$. If $\text{Axis}_{\mathbb{A}}^{v_0}(\gamma)$ is finite we find some $v \in VA$ and infinitely many integers $z \in \mathbb{Z}$ such that there exists some reduced preimage p_{γ}^z of $u \cdot q_{\gamma}^z$ with $\omega(p_{\gamma}^z) = v \in VA$. Since $B_{f(v)}$ is a finite group there exists some $z, w \in \mathbb{Z}$ with $z \neq w$ such that $[\mu(p_{\gamma}^z)] \cdot [b] = [u] \cdot [q_{\gamma}]^z$ and $[\mu(p_{\gamma}^w)] \cdot [b] = [u] \cdot [q_{\gamma}]^w$. Therefore

$$\gamma^{w-z} = [q^{w-z}] = [u] \cdot [q_{\gamma}]^w \cdot ([u] \cdot [q_{\gamma}]^z)^{-1} = [\mu(p_{\gamma}^w)] \cdot [b][b^{-1}][\mu(p_{\gamma}^z)^{-1}] = \varphi_{\mathfrak{f}}([p_{\gamma}^w(p_{\gamma}^z)^{-1}]) \in U.$$

For the other implication assume that $\langle \gamma^d \rangle \in U$. Hence there exists a reduced closed \mathbb{A} -path p at v_0 such that $[\mu(p)] = [u] \cdot [q_{\gamma}]^d [u]^{-1} \in U$. Thus the endpoints of the reduced preimages corresponding to the \mathbb{B} -paths $u \cdot q_{\gamma}^z$ and $u \cdot q_{\gamma}^w$ for $z, w \in \mathbb{Z}$ coincide whenever $w \in z + d\mathbb{Z}$. It follows that there are only finitely $v \in VA$ with the property that there exists some $z \in \mathbb{Z}$ and some preimage p_{γ}^z of $u \cdot q_{\gamma}^z$ with $\omega(p_{\gamma}^z) = v$. Therefore $\text{Axis}_{\mathbb{A}}^{v_0}(\gamma)$ must be a finite subgraph of \mathbb{A} . \square

Note that the following observation is more or less the generalization of Lemma 2.15 [45] to our situation.

Lemma 4.10. Let \mathbb{B} be a finite graph of groups and let $c_1, c_2 \in G = \pi_1(\mathbb{B}, u_0)$ be elements acting hyperbolic on $\Gamma = (\mathbb{B}, u_0)$. Consider some $g \in G$, some f.g. subgroup $U \leq G$ and let Γ_U be some minimal U -invariant subtree Γ_U of Γ , s.t. $\text{Axis}(c_1) \cap g\text{Axis}(c_2)$ and $\Gamma_U \cap \text{Axis}(c_i)$, $i \in \{1, 2\}$, are compact arcs. Then there are only finitely many pairs $(n, m) \in \mathbb{Z}^2$ such that $c_1^n g c_2^m \in U$.

Proof: If $c_1^n g c_2^m \notin U$ for any pair $(n, m) \in \mathbb{Z}^2$ then there is nothing to show. So assume the contrary.

After replacing g by $c_1^n g c_2^m \in U$ for some suitable $(n, m) \in \mathbb{Z}^2$ if necessary, we can assume that $g \in U$. Let α be the path connecting $\text{Axis}(c_1)$ and $g\text{Axis}(c_2) = \text{Axis}(c_2^{g^{-1}})$ and choose some base point u_0 in α . If α is the empty path, choose u_0 in $\text{Axis}(c_1) \cap g\text{Axis}(c_2)$. Clearly for large enough $k \in \mathbb{N}$ it follows that for any $x \in \text{Axis}(c_1) \cup \alpha \cup g\text{Axis}(c_2)$ satisfying $d(u_0, x) \geq k$ holds $x \notin \Gamma_U$. Let c_i be the translation length of c_i for $i \in \{1, 2\}$. Furthermore let $g = [q]$ for some reduced \mathbb{B} -path q . Let $|q|$ be the \mathbb{B} -path length of q . Now choose $n, m \in \mathbb{Z}$ such $|c_1^n| \geq k + |q|$ and $|c_2^m| \geq k + |q|$. Let s be the nearest point in Γ_U to $c_1^n g c_2^m(u_0)$ and let r be the nearest point in Γ_U to $g c_2^m(u_0)$. Then the geodesic arc $[c_1^n g c_2^m(u_0), g c_2^m(u_0)]$ intersects Γ_U precisely in the arc $[s, r]$. Thus $c_1^n g c_2^m(u_0) \notin \Gamma_U$ implying that $c_1^n g c_2^m \notin U$.

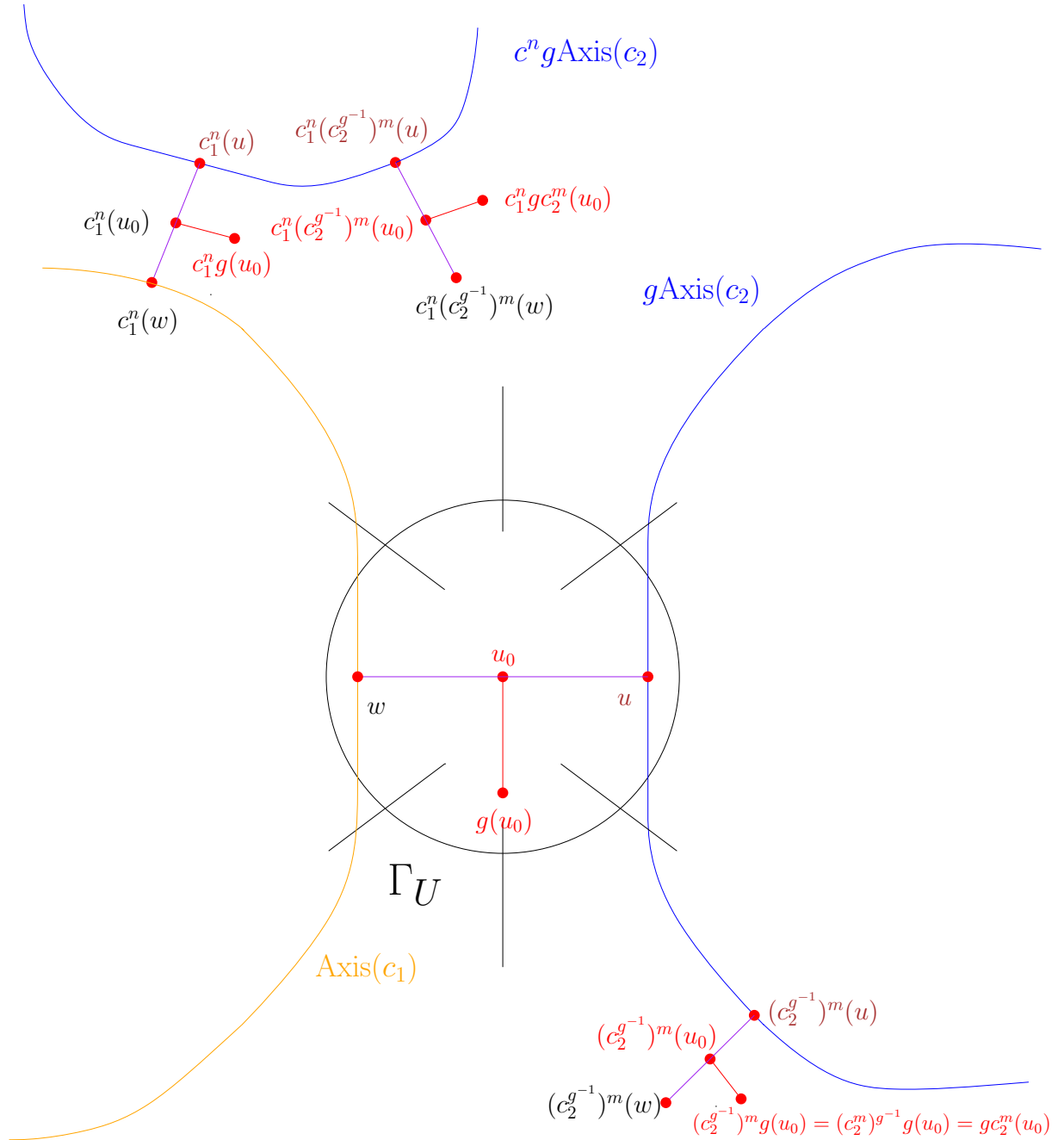

Figure 5: The case where α is not empty and q doesn't cause a backtracking on $\text{Axis}(c_1)$ or $g\text{Axis}(c_2)$. \square

4.2 Stars of groups with certain vertex groups

Definition 4.11. Let G be a group and I an index set. We call a family $(A_i)_{i \in I}$ of subgroups of G almost conjugacy separated if $|A_i \cap A_j^g| = \infty$ for some $g \in G$ implies $i = j$.

Definition 4.12. We call a finite tree of groups a star of groups if there exists some "midpoint" $u \in VB$ such that $d(u, u') \leq 1$ for any $u' \in VB$.

Note that the following statement is more or less the generalization of Lemma 2.16 [45] to our situation. Since the proof of this statement in [45] is less detailed, we give some detailed proof of our related statement. To do this we will make use of Lemma 4.10 in a similar way as the proof of Lemma 2.16 in [45] makes use of Lemma 2.15 in [45].

Lemma 4.13. Let \mathbb{B} be a star of groups with midpoint u and $EB^+ = \{l \in EB \mid \alpha(l) = u \wedge |\alpha_l(B_l)| = \infty\}$. Assume that the following holds:

1. $B_u = \pi_1(\mathbb{B}', u'_0)$ for some (k, C) -acylindrical graph of groups \mathbb{B}' .
2. Let $l \in EB$ with $\alpha(l) = u$. Then either $\alpha_l(B_l)$ is finite or $\alpha_l(B_l) = \text{Stab}_{B_u}(\text{Axis}(c))$ for some $c \in B_u$ acting properly hyperbolically on $\Gamma' = \widetilde{(\mathbb{B}', u'_0)}$. In particular $\alpha_l(B_l)$ is virtually infinite cyclic by Corollary 4.5.
3. The family $(\alpha_l(B_l))_{l \in EB^+}$ of subgroups of B_u is almost conjugacy separated in B_u .

Then \mathbb{B} is (k, C) -acylindric and any hyperbolic element $\gamma \in \pi_1(\mathbb{B}, u_0)$ is proper.

Proof: Note that the (k, C) -acylindricity of \mathbb{B} is a direct consequence of 4.3 combined with 4.4 since the family $(\alpha_l(B_l))_{l \in EB^+}$ is almost conjugacy separated in the fundamental group B_u of the (k, C) -acylindrical graph of groups \mathbb{B}' and $\alpha_l(B_l) = \text{Stab}_{B_u}(\text{Axis}(c))$ for some $c \in B_u$ acting properly hyperbolically on $\Gamma' = \widetilde{(\mathbb{B}', u'_0)}$ for any $l \in EB^+$.

It's left to show that any hyperbolic element is proper. Let $f : \mathbb{A} \rightarrow \mathbb{B}$ be a cover representing $U := \varphi_f(\pi_1(\mathbb{A}, v_0))$, $v_0 \in VA$. Similar as in the proof of Lemma 4.9 it follows that $U \cap \langle \gamma \rangle \neq \{1_G\}$ implies that $\text{Axis}_{\mathbb{A}}^{v_0}(\gamma)$ is a finite subgraph of A . So we are left to show the converse. Assume that $\text{Axis}_{\mathbb{A}}^{v_0}(\gamma)$ is finite and let $\gamma = [q] = [u][q_\gamma][u]^{-1}$ with $q_\gamma = b_0, l_1^z, b_1, \dots, l_n^z, b_n$ and p_γ^z , $z \in \mathbb{Z}$ as in Remark 4.7. If U is a finite index subgroup of G the claim is obvious, since in this case $U \cap \langle \gamma \rangle$ is of finite index in $\langle \gamma \rangle$. Thus assume that $U = \varphi_f(\pi_1(\mathbb{A}, v_0))$ has infinite index in G . Since γ acts hyperbolically on $\widetilde{(\mathbb{B}, u_0)}$ it follows that $\text{Axis}(\gamma)$ is an infinite line in $\widetilde{(\mathbb{B}, u_0)}$ and as $\text{Axis}_{\mathbb{A}}^{v_0}(\gamma)$ is assumed to be finite it follows that the image under the natural map $h \circ f_f^{-1} : \widetilde{(\mathbb{B}, u_0)} \rightarrow A$ of $\text{Axis}(\gamma)$ (see Definition 4.6) crosses some path e_1, e_2 in A with $\omega(e_1) = \alpha(e_2) = v \in VA$ infinitely many times. W.l.o.g. we can assume that $f(v) = u$. Let $l_1 := f(e_1)$ and $l_2 := f(e_2)$. By applying some auxiliary modification (see 3.45.3) we can assume that $g_{e_2}^\alpha = 1_{B_u}$. Thus w.l.o.g. there are infinitely many $z \in \mathbb{N}$ such that for reduced preimages p_γ^z and p_γ^{z-1} holds $p_\gamma^z = p_\gamma^{z-1} \cdot (a_0^z, e_1^z, \dots, e_k^z, a_k^z, e_{k+1}^z, \dots, e_n^z, a_n^z)$ with $e_k^z = e_1$ and $e_{k+1}^z = e_2$ s.t. $a_k^z \in A_v$ and

$$f_v(a_k^z) = g_{e_1}^{\omega^{-1}} x_1^z b_k x_2^z = (x_1^z)^{g_{e_1}^{\omega}} (g_{e_1}^{\omega^{-1}} b_k) x_2^z$$

for some $k \leq n$, $x_1^z \in X_1 = \omega_{l_1}(B_{l_1})$ and $x_2^z \in X_2 = \alpha_{l_2}(B_{l_2})$. We distinguish three cases:

1. Assume that $|X_2 : f_v(A_v) \cap X_2| < \infty$. For any $z \in \mathbb{Z}$ choose some reduced preimage

$$p_\gamma^z = p_\gamma^{z-1} \cdot (a_0^z, e_1^z, \dots, e_k^z, a_k^z, e_{k+1}^z, \dots, e_n^z, a_n^z)$$

of $[u][q_\gamma^z]$ and consider the subpath $p_z := p_\gamma^{z-1} \cdot (a_0^z, e_1^z, \dots, e_k^z, a_k^z)$. By assumption there are infinitely many $z \in \mathbb{Z}$ such that $e_k^z = e_1$ and $e_{k+1}^z = e_2$ in the above decomposition of some fixed preimage of $[u][q_\gamma^z]$. Then it follows that for these $z \in \mathbb{Z}$ there exists some $x_z^z \in X_2$ satisfying

$$[\mu(p_z) \cdot x_z^z] = [u][q_\gamma^{z-1} \cdot (b_0, l_1^\gamma, b_1 \dots, l_k^\gamma, b_k)].$$

Since $|X_2 : f_v(A_v) \cap X_2| < \infty$, we find some $z, w \in \mathbb{N}$ with $z > w$ and reduced preimages

$$\begin{aligned} p_\gamma^z &= p_\gamma^{z-1} \cdot (a_0^z, e_1^z, \dots, e_k^z, a_k^z, e_{k+1}^z, \dots, e_n^z, a_n^z), \\ p_\gamma^w &= p_\gamma^{w-1} \cdot (a_0^w, e_1^w, \dots, e_k^w, a_k^w, e_{k+1}^w, \dots, e_n^w, a_n^w) \end{aligned}$$

satisfying $e_k^z = e_k^w = e_1$, $e_{k+1}^z = e_{k+1}^w = e_2$ such that

$$[\mu(p_z) \cdot x_z] = [u][q_\gamma^{z-1}][(b_0, l_1^\gamma, b_1 \dots, l_k^\gamma, b_k)]$$

and

$$[\mu(p_w) \cdot x_w] = [u][q_\gamma^{w-1}][(b_0, l_1^\gamma, b_1 \dots, l_k^\gamma, b_k)]$$

for some $x_z, x_w \in B_{f(v)}$ satisfying $f_v(A_v)x_z = f_v(A_v)x_w$. Therefore there exists some $a \in A_v$ such that $x_z = f_v(a)x_w$ and it follows

$$g^{z-w} = [u][q_\gamma^{z-1}][(b_0, l_1^\gamma, b_1 \dots, l_k^\gamma, b_k)] \cdot ([u][q_\gamma^{w-1}][(b_0, l_1^\gamma, b_1 \dots, l_k^\gamma, b_k)])^{-1} =$$

$$[\mu(p_z) \cdot x_z] \cdot ([\mu(p_w) \cdot x_w])^{-1} = [\mu(p_z)(f_v(a)x_w)x_w^{-1} \cdot \mu(p_w^{-1})] = [\mu(p_z \cdot a \cdot p_w^{-1})] \in U.$$

Hence $\mathbb{Z} \cong \langle g^{z-w} \rangle \leq U$.

2. If $|X_1^{g_{e_1}^\omega} : f_v(A_v) \cap X_1^{g_{e_1}^\omega}| < \infty$ it follows by Remark 3.70 that $f_{v'}(A_{v'}) \cap g_{e_1}^\alpha \alpha_{l_1}(B_{l_1})(g_{e_1}^\alpha)^{-1}$ is of finite index in $g_{e_1}^\alpha \alpha_{l_1}(B_{l_1})(g_{e_1}^\alpha)^{-1}$ for $v' = \alpha(e_1)$ and therefore we can proceed as before for v' instead of v .
3. So we are left with the case

$$|X_2 : f_v(A_v) \cap X_2| = \infty = |X_1^{g_{e_1}^\omega} : f_v(A_v) \cap X_1^{g_{e_1}^\omega}|.$$

Choose $c_1 \in X_1$ and $c_2 \in X_2$ generating maximal cyclic subgroups and let R be a right transversal of $\langle c_1 \rangle$ in X_1 and L be a left transversal of $\langle c_2 \rangle$ in X_2 . Note that by assumption L and R are finite sets of elements. Moreover set $y = g_{e_1}^\omega$. Note that the assumption implies that c_1^y, c_2 act properly hyperbolically on $\Gamma' = (\mathbb{B}', u_0')$ and

$$f_v(A_v) \cap \langle c_1^y \rangle = \{1_{B_{u_0}}\} = f_v(A_v) \cap \langle c_2 \rangle.$$

Let $\Gamma'_{f_v(A_v)}$ be some minimal $f_v(A_v)$ -invariant subtree of Γ' . Since c_1^y, c_2 are proper, it follows that $\Gamma'_{f_v(A_v)} \cap y^{-1}\text{Axis}(c_1)$ and $\Gamma'_{f_v(A_v)} \cap \text{Axis}(c_2)$ are compact arcs in $\Gamma'_{f_v(A_v)}$. Consider some $l \in L$ and some $r \in R$. If $y^{-1}\text{Axis}(c_1) \cap (y^{-1}lb_k r)\text{Axis}(c_2)$ is an infinite ray in Γ' it follows that $\text{Axis}(c_1) \cap lb_k r \text{Axis}(c_2)$ is as well an infinite ray in Γ' . Thus by applying Lemma 4.3 we deduce that $|\omega_{l_1}(B_{l_1}) \cap \alpha_{l_2}(B_{l_2})^{(lb_k r)^{-1}}| = \infty$ and therefore $l_1 = l_2$ since the family $(\alpha_l(B_l))_{l \in EB^+}$ is almost conjugacy separated. Moreover by Corollary 4.4 it follows $b_k \in X_1 = X_2$ contradicting that q is reduced. Hence $\text{Axis}(c_1^y) \cap (y^{-1}lb_k r)\text{Axis}(c_2)$ is compact and therefore we can apply Lemma 4.10 to $g = y^{-1}lb_k r$, $f_v(A_v)$ and the proper hyperbolic elements $c_1^y, c_2 \in B_{u_0}$. It follows that for any $l \in L$ and any $r \in R$ there are only finitely many pairs $(n, m) \in \mathbb{Z}^2$ satisfying

$$(c_1^n l)^y (y^{-1} b_k) (r c_2^m) = (c_1^n)^y (y^{-1} l b_k r) c_2^m \in f_v(A_v)$$

implying that there are only finitely many pairs $(x_1^z, x_2^z) \in X_1 \times X_2$ satisfying

$$(x_1^z)^{g_{e_1}^\omega} ((g_{e_1}^\omega)^{-1} b_k) x_2^z \in f_v(A_v) \quad (*)$$

since L and R are finite sets of elements.

Similar to the first case choose for any $z \in \mathbb{Z}$ some reduced preimage

$$p_\gamma^z = p_\gamma^{z-1} \cdot (a_0^z, e_1^z, \dots, e_k^z, a_k^z, e_{k+1}^z, \dots, e_n^z, a_n^z)$$

of $[u][q_\gamma^z]$ and consider again the subpath $p_z := p_\gamma^{z-1} \cdot (a_0^z, e_1^z, \dots, e_k^z, a_k^z)$. As before there are infinitely many $z \in \mathbb{Z}$ such that $e_k^z = e_1$ and $e_{k+1}^z = e_2$ in the above decomposition of some fixed preimage of $[u][q_\gamma^z]$. Hence it follows that for these $z \in \mathbb{Z}$ there exists some $x_2^z \in X_2$ satisfying

$$[\mu(p_z) \cdot x_2^z] = [u][q_\gamma^{z-1} \cdot (b_0, l_1^\gamma, b_1 \dots, l_k^\gamma, b_k)].$$

Now it is easily verified by (*) that there exists some $z, w \in \mathbb{N}$ with $z > w$ and reduced preimages

$$p_\gamma^z = p_\gamma^{z-1} \cdot (a_0^z, e_1^z, \dots, e_k^z, a_k^z, e_{k+1}^z, \dots, e_n^z, a_n^z),$$

$$p_\gamma^w = p_\gamma^{w-1} \cdot (a_0^w, e_1^w, \dots, e_k^w, a_k^w, e_{k+1}^w, \dots, e_n^w, a_n^w)$$

satisfying $e_k^z = e_k^w = e_1$, $e_{k+1}^z = e_{k+1}^w = e_2$ and

$$[\mu(p_z) \cdot x_2^z] = [u][q_\gamma^{z-1}][(b_0, l_1^\gamma, b_1 \dots, l_k^\gamma, b_k)]$$

and

$$[\mu(p_w) \cdot x_2^w] = [u][q_\gamma^{w-1}][(b_0, l_1^\gamma, b_1 \dots, l_k^\gamma, b_k)]$$

with $x_2^z = x_2^w$. Now the claim follows as in the first case for $a = 1_{A_v}$ completing the proof. \square

Definition 4.14. Let \mathbb{B} be a finite graph of groups and let $f: \mathbb{A} \rightarrow \mathbb{B}$ be a cover representing some f.g. subgroup $U = \varphi_f(\pi_1(\mathbb{A}, v_0)) \leq G = \pi_1(\mathbb{B}, u_0)$. Consider a set of proper hyperbolic elements $\{\gamma_i\}$ such that $\langle \gamma_i \rangle \cap U = 1_G$ for any i . Then we call the set $\{\gamma_i\}$ disparate in \mathbb{A} , if the following conditions are satisfied:

1. $\text{Axis}_{\mathbb{A}}^{v_0}(\gamma) \setminus A'$ consists of one or two unbounded components for any finite connected subgraph A' of A containing the underlying graph of $\text{core}(\mathbb{A}, v_0)$ and any $\gamma \in \{\gamma_i\}$.
2. $\text{Axis}_{\mathbb{A}}^{v_0}(\gamma_i) \cap \text{Axis}_{\mathbb{A}}^{v_0}(\gamma_{i'})$ is finite for any i, i' with $i \neq i'$.
3. Let $\gamma \in \{\gamma_i\}$ and assume that $\text{Axis}_{\mathbb{A}}^{v_0}(\gamma) \setminus A'$ consists of only one unbounded component for any finite connected subgraph A' of A containing the underlying graph of $\text{core}(\mathbb{A}, v_0)$. Then there exists some $g \in \text{Stab}_U(\text{Axis}(\gamma))$ such that $(\gamma^{-d})^g = \gamma^d$.
4. There exists some $m \in \mathbb{N}$ such that for any $\gamma \in \{\gamma_i\}$ the following holds:

Let $\gamma = [u_\gamma][q_\gamma][u_\gamma]^{-1}$ with u_γ and q_γ chosen as in Remark 4.7. Clearly there exists a vertex $u \in VB$ such that for any $z \in \mathbb{Z}$ the \mathbb{B} -path $u_\gamma q_\gamma^z$ terminates at u . Then for any $z \in m\mathbb{Z} \setminus \{0\}$ and any reduced preimage p_γ^z of $[u_\gamma][q_\gamma]^z$ holds

$$(f_{\omega(p_\gamma^z)}(A_{\omega(p_\gamma^z)}))^b = f_{\omega(p_\gamma^m)}(A_{\omega(p_\gamma^m)}) \leq B_u$$

for some $b \in B_u$. In particular for any $z \in m\mathbb{Z}$ the two subgroups $f_{\omega(p_\gamma^z)}(A_{\omega(p_\gamma^z)})$ and $f_{\omega(p_\gamma^m)}(A_{\omega(p_\gamma^m)})$ of the vertex group B_u are conjugate in B_u .

Lemma 4.15. *Let \mathbb{B} be a finite (k, C) -acylindrical graph of groups, such that any vertex group B_u , $u \in VB$, contains only finitely many conjugacy classes of finite subgroups and let $\mathfrak{f} : \mathbb{A} \rightarrow \mathbb{B}$ representing some f.g. subgroup $U = \varphi_{\mathfrak{f}}(\pi_1(\mathbb{A}, v_0)) \leq G = \pi_1(\mathbb{B}, u_0)$. Let $(A_i)_{i \in \{1, \dots, n\}}$, $n \in \mathbb{N}$, be a finite family of almost conjugacy separated subgroups of $G = \pi_1(\mathbb{B}, u_0)$ such that $A_i = \text{Stab}_G(\text{Axis}(c_i))$ for some c_i acting properly hyperbolically on (\mathbb{B}, u_0) , $i \in \{1, \dots, n\}$. Let $\{c_{i_j}^{g_j}\}$ be a finite set of conjugates of these generators such that the following holds:*

1. $U g_j^{-1} A_{i_j} \neq U g_{j'}^{-1} A_{i_{j'}}$ for any j, j' with $i_j = i_{j'}$.
2. $\langle c_{i_j}^{g_j} \rangle \cap U = \{1_G\}$.

Then $\{c_{i_j}^{g_j}\}$ is disparate in \mathbb{A} .

Proof:

1. This follows directly from the fact that any $\gamma \in \{c_{i_j}^{g_j}\}$ is proper hyperbolic.
2. Assume that $\text{Axis}_{\mathbb{A}}^{v_0}(\gamma_1) \cap \text{Axis}_{\mathbb{A}}^{v_0}(\gamma_2)$ is infinite with $\gamma_1 = c_{i_j}^{g_j}$ and $\gamma_2 = c_{i_{j'}}^{g_{j'}}$ for some j, j' . Choose some minimal U -invariant subtree Γ_U of $\Gamma = \widetilde{(\mathbb{B}, u_0)}$. By (k, C) -acylindricity, after enlarging Γ_U if necessary, it can be assumed that every edge stabilizer in $\Gamma \setminus \Gamma_U$ is finite. As a consequence U permutes the components of $\Gamma \setminus \Gamma_U$ with finite stabilizers. Since $\text{Axis}_{\mathbb{A}}^{v_0}(\gamma_1) \cap \text{Axis}_{\mathbb{A}}^{v_0}(\gamma_2)$ is infinite it is easily verified that there exists some $u^{-1} \in U$, such that $u^{-1} \text{Axis}(\gamma_1) \cap \text{Axis}(\gamma_2)$ contains infinitely many edges. Thus $u^{-1} g_j^{-1} \text{Axis}(c_{i_j}) \cap g_{j'}^{-1} \text{Axis}(c_{i_{j'}})$ is an infinite ray in Γ . Applying Lemma 4.2.2 we deduce $|A_{i_j}^{g_j u} \cap A_{i_{j'}}^{g_{j'}}| = \infty$ implying that $i_j = i_{j'}$. Moreover by Lemma 4.2.3 it follows $g_j u g_{j'}^{-1} \in A_{i_j}$ and therefore $U g_j^{-1} A_{i_j} = U g_{j'}^{-1} A_{i_{j'}}$.
3. Let $\gamma = c_{i_j}^{g_j}$ for some j and assume that $\text{Axis}_{\mathbb{A}}^{v_0}(\gamma) \setminus A'$ consists of only one unbounded component for any finite connected subgraph A' of A containing the underlying graph of $\text{core}(\mathbb{A}, v_0)$. Since γ is proper and $\langle \gamma \rangle \cap U = \{1\}$ it follows that $\text{Axis}(\gamma) \setminus \Gamma_U$ consists of two unbounded components, say l_1, l_2 .

Similarly as in the second part of this proof, it follows that there exists some $u^{-1} \in U$ mapping infinitely many edges of l_1 to some edge of l_2 . Thus u is a reflection element which clearly acts elliptic on $\text{Axis}(\gamma)$. Hence by Corollary 4.4 case 2 we deduce that $u \in \text{Stab}_U(\text{Axis}(\gamma))$ and $(\gamma^m)^u = \gamma^{-m}$ for some $m \in \mathbb{N}$ proving 3.

4. Let $\gamma = c_{i_j}^{g_j}$ for some j and let Γ_U as above. After enlarging Γ_U further if necessary, we can assume that for any $v, v' \in \text{Axis}(\gamma) \setminus \Gamma_U$ the finite subgroups $\text{Stab}_U(v)$ and $\text{Stab}_U(v')$ are isomorphic. Clearly the group $\langle \gamma \rangle$ acts on the set of conjugacy classes of finite subgroups in B_u if u is the terminal vertex of the paths $u_\gamma q_\gamma^z$, $z \in \mathbb{Z}$. By assumption, there are only finitely many conjugacy classes of finite subgroups in B_u . Thus there exists $m \in \mathbb{N}$ such that $\langle \gamma^m \rangle$ is the kernel of this action. Hence for any $z \in m \cdot \mathbb{Z}$ and for any finite subgroup E of the embedded vertex group $\theta(B_u) \leq \pi_1(\mathbb{B}, u_0)$, we have $\gamma^{-z} E \gamma^z = E^b$ for some $b \in \theta(B_u)$. By replacing m by some multiple of m , we can assume that the vertex $[u][q_\gamma]^m \cdot B_u$ lies in $\text{Axis}(\gamma) \setminus \Gamma_U$ and $f_{\omega(p_\gamma^m)}(A_{\omega(p_\gamma^m)}) \cong f_{\omega(p_\gamma^z)}(A_{\omega(p_\gamma^z)})$ for any $z \in m \cdot \mathbb{Z} \setminus \{0\}$. Now the claim is easily verified if $\theta^{-1}(E)$ is assumed to be $f_{\omega(p_\gamma^z)}(A_{\omega(p_\gamma^z)})$ and by replacing m again by some multiple of m , since $\{c_i^{g_j}\}$ is a finite set of elements. \square

Recall that the following is true:

Remark 4.16. *Let A be a virtually cyclic group. Then for any infinite order element $c \in A$, there exists some $n \in \mathbb{N}$ such that $\langle c^n \rangle$ is normal in A .* \square

Theorem 4.17. *Let \mathbb{B} be a finite (k, C) -acylindrical graph of groups with subgroup separable fundamental group $G = \pi_1(\mathbb{B}, u_0)$, such that any vertex group B_u , $u \in VB$, contains only finitely many conjugacy classes of finite subgroups and let $\mathfrak{f} : \mathbb{A} \rightarrow \mathbb{B}$ be a folded morphism representing some f.g. subgroup $U = \varphi_{\mathfrak{f}}(\pi_1(\mathbb{A}, v_0)) \leq G$ with A finite. Consider a finite family of finite subgroups $(E_r)_{r \in \{1, \dots, R\}}$, $R \in \mathbb{N}$, and let $(A_i)_{i \in \{1, \dots, I\}}$, $I \in \mathbb{N}$, be a finite family of almost conjugacy separated subgroups of $G = \pi_1(\mathbb{B}, u_0)$, such that $A_i = \text{Stab}_G(\text{Axis}(c_i))$ for some c_i acting properly hyperbolically on (\mathbb{B}, u_0) for any i . Let $C_i := \langle c_i \rangle$. Then for any two finite sets of conjugates $\{E_{r_s}^{g_s}\}$ and $\{A_{i_j}^{g_j}\}$ satisfying*

1. $U \cdot g_j^{-1} \cdot A_{i_j} \neq U \cdot g_{j'}^{-1} \cdot A_{i_{j'}}$, for any j, j' with $i_j = i_{j'}$.
2. $U \cdot g_s^{-1} \cdot E_{r_s} \neq U \cdot g_{s'}^{-1} \cdot E_{r_{s'}}$ for any s, s' with $r_s = r_{s'}$.

and any $g \in G \setminus U$ there exists some $n \in \mathbb{N}$ such that for any (positive) multiple d of n there exists some finite index subgroup H_d of G containing U such that the following holds:

1. If $|A_{i_j}^{g_j} : (A_{i_j}^{g_j} \cap U)| < \infty$ for some j then $A_{i_j}^{g_j} \cap H_d = A_{i_j}^{g_j} \cap U$.
2. If $|A_{i_j}^{g_j} : (A_{i_j}^{g_j} \cap U)| = \infty$ for some j then $A_{i_j}^{g_j} \cap H_d = (A_{i_j}^{g_j} \cap U) \cdot \langle (c_{i_j}^{g_j})^d \rangle$.
3. $H_d \cdot g_j^{-1} \cdot A_{i_j} \neq H_d \cdot g_{j'}^{-1} \cdot A_{i_{j'}}$, for any j, j' with $i_j = i_{j'}$.
4. $H_d \cdot g_s^{-1} \cdot E_{r_s} \neq H_d \cdot g_{s'}^{-1} \cdot E_{r_{s'}}$, for any s, s' with $r_s = r_{s'}$.
5. $g \notin H_d$.

We say that \mathbb{B} has property \mathcal{L}^+ .

Proof: So let \mathbb{B} be a finite graph of groups that has property \mathcal{L} and let $\mathfrak{f} : \mathbb{A} \rightarrow \mathbb{B}$ be a folded morphism of finite graphs of groups representing $U = \varphi_{\mathfrak{f}}(\pi_1(\mathbb{A}, v_0))$. Moreover let $(E_r)_{r \in \{1, \dots, R\}}$, $R \in \mathbb{N}$, be a finite family of finite subgroups and let $(A_i)_{i \in \{1, \dots, I\}}$, $I \in \mathbb{N}$, be a finite family of almost conjugacy separated subgroups of $G = \pi_1(\mathbb{B}, u_0)$, such that $A_i = \text{Stab}_G(\text{Axis}(c_i))$ for some c_i acting properly hyperbolically on (\mathbb{B}, u_0) for any i . Assume that $|A_{i_j}^{g_j} \cap U| < \infty$ for some j . Thus $C_{i_j}^{g_j} \cap U = \{1_G\}$. So let $C := \{c_{i_j}^{g_j} | C_{i_j}^{g_j} \cap U = \{1_G\}\}$. W.l.o.g. we can regard \mathbb{A} as a subgraph of groups of some graph of groups $\tilde{\mathbb{A}}$ corresponding to a covering $\tilde{\mathfrak{f}} : \tilde{\mathbb{A}} \rightarrow \mathbb{B}$ representing U such that \mathbb{A} contains $\text{core}(\tilde{\mathbb{A}}, v_0)$. Note that $Ug_s^{-1}E_{r_s} \neq Ug_{s'}^{-1}E_{r_{s'}}$ for $s \neq s'$ with $r_s = r_{s'}$ is equivalent to the fact that $g_{s'}^{-1}xg_s \notin U$ for any $x \in E_{r_s}$. By extending \mathbb{A} if necessary we can assume that for any $s \neq s'$ with $r_s = r_{s'}$ and any $x \in E_{r_s}$ we have that a reduced preimage in $\tilde{\mathbb{A}}$ of the \mathbb{B} -path q satisfying $[q] = g_{s'}^{-1}xg_s$ is already an \mathbb{A} -path as well as we can assume that a reduced preimage in $\tilde{\mathbb{A}}$ of the \mathbb{B} -path p' satisfying $[p'] = g$ is already an \mathbb{A} -path. By extending $\tilde{\mathbb{A}}$ further if necessary, we can assume that for any larger finite connected subgraph A' of $\tilde{\mathbb{A}}$ containing the underlying graph of $\text{core}(\tilde{\mathbb{A}}, v_0)$ the number of connected components of $\text{Axis}_{\tilde{\mathbb{A}}}^{v_0}(c) \setminus A'$ coincides with the number of connected components of $\text{Axis}_{\mathbb{A}}^{v_0}(c) \setminus A$ for any c_i . For $t \in \{1, 2\}$ let now $C^t \subseteq C$ such that for any $\gamma \in C^t$ we have that $\text{Axis}_{\tilde{\mathbb{A}}}^{v_0}(\gamma) \setminus A$ consists of t connected components. By Lemma 4.15 the set C is disparate. For any $\gamma \in C$ consider a decomposition $\gamma = [u_\gamma][q_\gamma][u_\gamma]^{-1}$ as in Remark 4.7 and choose for any $z \in \mathbb{Z}$ a reduced preimage p_γ^z of $u_\gamma q_\gamma^z$. Consider some $\gamma \in C^1$. Since $\text{Axis}_{\tilde{\mathbb{A}}}^{v_0}(\gamma) \setminus A$ consists of only one unbounded component, following Lemma 4.15.3 there exists some vertex \tilde{v} in $\text{Axis}(\gamma)$ and some reflection element $g_\gamma \in \text{Stab}_U(\tilde{v})$ such that $(\gamma^m)^{g_\gamma} = \gamma^{-m}$ for any $m \in \mathbb{N}$. Let v be the image of \tilde{v} under the natural projection $\mathfrak{h} : (\mathbb{B}, u_0) \rightarrow \tilde{\mathbb{A}}$. Clearly we have that $v \in VA \subseteq V\tilde{A}$, since $g_\gamma \in U$. Thus there exists an \mathbb{A} -path p representing $g_\gamma \in U$, i.e. there exists $z \in \mathbb{Z}$ and \mathbb{B} -paths q_1, q_2 satisfying $q_1 \cdot q_2 = q_\gamma$ such that

$$g_\gamma = [\mu(p)] = [u_\gamma q_\gamma^z q_1 \cdot a \cdot q_1^{-1} g_\gamma^{-z} u_\gamma^{-1}]$$

for some $a \in A_v$. Thus by disparity it is easily verified that there exists some $n \in \mathbb{N}$ such that for any positive multiple d of n the following conditions are satisfied:

1. For any $\gamma \in C$ it follows $\omega(p_\gamma^d), \omega(p_\gamma^{-d}) \notin A$.

2. For any $\gamma \in C$ it follows

$$(f_{\omega(p_\gamma^d)}(A_{\omega(p_\gamma^d)}))^b = f_{\omega(p_\gamma^{-d})}(A_{\omega(p_\gamma^{-d})}) \leq B_u$$

for some $b \in B_u$ if u is the terminal vertex of the \mathbb{B} -path $u_\gamma q_\gamma$.

3. For any $\gamma \in C^2$ we have $\omega(p_\gamma^d) \neq \omega(p_\gamma^{-d})$.

4. For any $\gamma \in C^1$ there exists some element $g_\gamma \in \text{Stab}_U(\text{Axis}(\gamma))$ such that $(\gamma^d)^{g_\gamma} = \gamma^{-d}$.

5. $\langle c_i^d \rangle$ is normal in A_i for any i .

Choose some fixed multiple d of $2n$ and set $d' = d/2$. Now let \mathbb{A}^1 be the smallest (connected) subgraph of groups of $\tilde{\mathbb{A}}$ containing \mathbb{A} and the endpoints of the preimages p_γ^z of $u_\gamma q_\gamma^z$, for any $z \in \{-d, d\}$ and any $\gamma \in C^2$ and the endpoints of the preimages $p_\gamma^{d'}$ of $u_\gamma q_\gamma^{d'}$ for any $\gamma \in C^1$.

W.l.o.g. we can assume that for any $\gamma \in C^2$ the last edges of the preimages p_γ^z for $z \in \{-d, d\}$ and for any $\gamma \in C^1$ the last edges of the preimage p_γ^d are free edges (see Construction 3.83). For any $\gamma \in C^2$ proceed now as follows. Let $b_z \in B_u$ with $[p_\gamma^z \cdot b_z] = [u_\gamma] \cdot [q_\gamma]^z$. By applying some auxiliary modification of type two to the terminal vertices of the \mathbb{A} -paths p_γ^z for $z \in \{-d, d\}$, we can assume that $b_{-d} = 1 = b_d$. Note that this process does not alter the fact that

$$(f_{\omega(p_\gamma^d)}(A_{\omega(p_\gamma^d)}))^{b^{-1}} = f_{\omega(p_\gamma^{-d})}(A_{\omega(p_\gamma^{-d})}) \leq B_u$$

for some $b \in B_u$ if $u \in VB$ is the terminal vertex of the \mathbb{B} -paths $u_\gamma q_\gamma^z$ for any $z \in \mathbb{Z}$. Let e_z^{-1} be the last edge in the \mathbb{A} -path $u_\gamma q_\gamma^z$ and let $v_z = \alpha(e_z)$ for $z \in \{-d, d\}$.

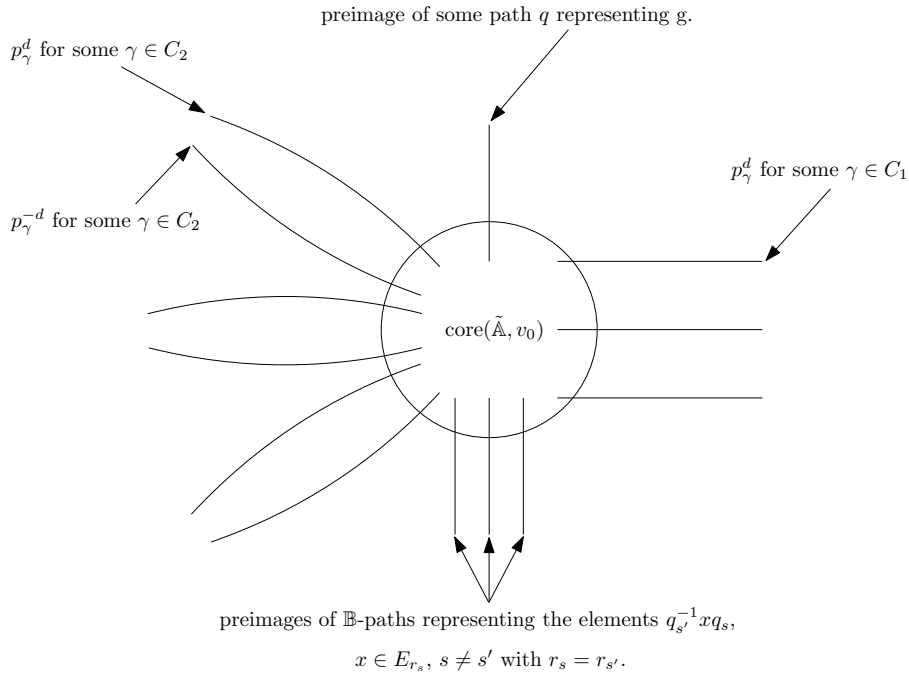

Figure 6: The graph of groups \mathbb{A}^1 .

By Remark 3.64 and since \tilde{f} is a cover it follows that there exists some edge $e \in E\tilde{A}$ such that $\alpha(e) = v_d$, $l = \tilde{f}(e) = \tilde{f}(e_{-d})$ and

$$f_{v_d}(A_{v_d})g_{e_d}^\alpha \alpha_l(B_l) \neq f_{v_d}(A_{v_d})g_e^\alpha \alpha_l(B_l) = f_{v_d}(A_{v_d})g_{e_{-d}}^\alpha \alpha_l(B_l)$$

by the choice of the \mathbb{B} -paths u_γ and q_γ . W.l.o.g. we can assume that $g_e^\alpha = g_{e_{-d}}^\alpha$. Then we have that

$$f_{v_d}(A_{v_d})^{b^{-1}g_e^\alpha} \cap \alpha_l(B_l) = f_{v_{-d}}(A_{v_{-d}})^{g_{e_{-d}}^\alpha} \cap \alpha_l(B_l).$$

Applying an auxiliary modification of type two again, we can switch $f_{v_d}(A_{v_d})$ to $f_{v_d}(A_{v_d})^{b^{-1}}$, g_e^α to bg_e^α and $g_{e_d}^\alpha$ to $bg_{e_d}^\alpha$. Thus

$$f_{v_d}(A_{v_d})^{g_e^\alpha} \cap \alpha_l(B_l) = f_{v_{-d}}(A_{v_{-d}})^{g_{e_{-d}}^\alpha} \cap \alpha_l(B_l).$$

implying that $f_e(A_e) = f_{e_{-d}}(A_{e_{-d}})$. Thus by Lemma 3.63 it follows that e, e_{-d} are free edges satisfying $e \approx e_{-d}$ (see Definition 3.79). So after defining $e_1 := e$ and $e_2 := e_{-d}$ we can exactly proceed as in Construction 3.83.

Note that since the edge groups are already equal this process creates a new edge ϵ satisfying $\alpha(\epsilon) = \alpha(e) = \alpha(e_d)$ and $\omega(\epsilon) = \alpha(e_{-d})$ with $g_\epsilon^\alpha = g_e^\alpha$ and $g_\epsilon^\omega = g_{e_{-d}}^\omega$. Proceed in this manner for any $\gamma \in C^2$ and call the resulting graph of groups \mathbb{A}^2 . Let $\mathfrak{f}^2 : \mathbb{A}^2 \rightarrow \mathbb{B}$ be the associated folded graphs of groups morphism. Again we can regard \mathbb{A}^2 as a subgraph of groups of a graph of groups $\tilde{\mathbb{A}}^2$ corresponding to some cover $\tilde{\mathfrak{f}}^2 : \tilde{\mathbb{A}}^2 \rightarrow \mathbb{B}$ representing the same subgroup as \mathbb{A}^2 . Moreover it follows for any $\gamma \in C^2$

$$[u_\gamma][q_\gamma]^{2d}[u_\gamma]^{-1} = [u_\gamma \cdot q_\gamma^d][q_\gamma^d \cdot u_\gamma^{-1}] = [\mu(p_\gamma^d)b][b^{-1} \cdot \mu((p_\gamma^{-d})^{-1})] \in \varphi_{\mathfrak{f}^2}(\pi_1(\mathbb{A}^2, v_0))$$

if μ is the now the associated map on \mathbb{A}^2 -path level corresponding to \mathfrak{f}^2 .

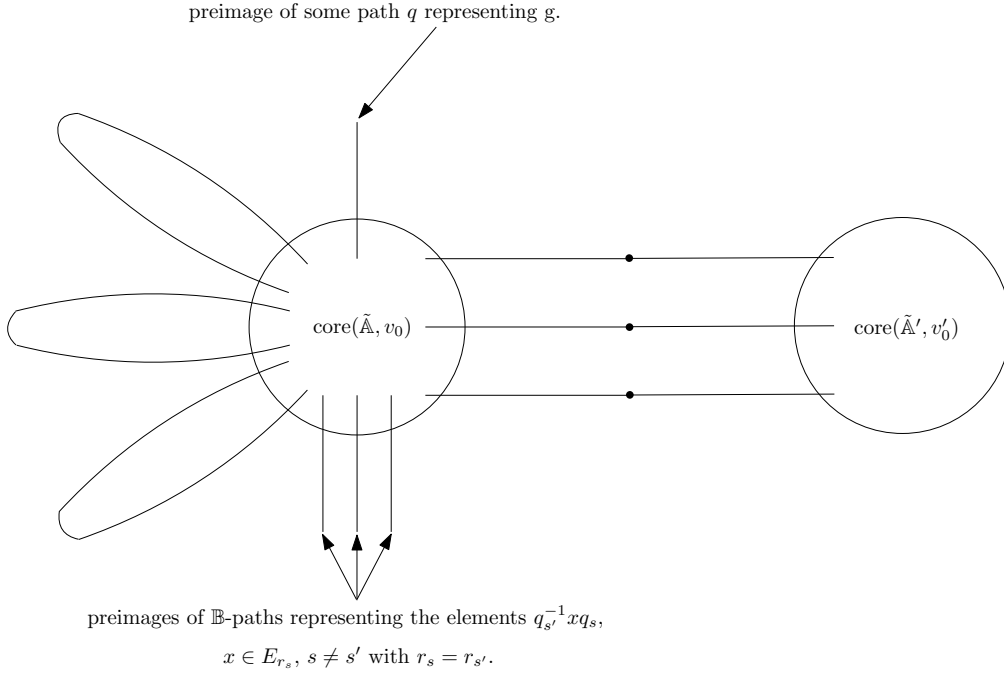

Figure 7: The graph of groups \mathbb{A}^{2d} .

Now take a copy $\tilde{\mathbb{A}}'$ of the covering graph of groups $\tilde{\mathbb{A}}$ and let v'_0 be the copy of v_0 in $\tilde{\mathbb{A}}$. Let \mathbb{A}^3 be the smallest (connected) subgraph of groups of $\tilde{\mathbb{A}}'$ containing $\text{core}(\tilde{\mathbb{A}}', v'_0)$ and the endpoints of the preimages $p_\gamma^{-d'}$ of $u_\gamma q_\gamma^{-d'}$ starting at v'_0 for any $\gamma \in C^1$. Now for any $\gamma \in C^1$ proceed as follows. Again by applying some auxiliary modification of type two to the terminal vertices of the \mathbb{A}^2 -paths $p_\gamma^{d'}$ and the \mathbb{A}^3 -paths $p_\gamma^{-d'}$, we can assume that $p_\gamma^z = \gamma^z$ for $z \in \{-d', d'\}$. As before this process does not alter the fact that

$$(f_{\omega(p_\gamma^{d'})}(A_{\omega(p_\gamma^{d'})}))^{b^{-1}} = f_{\omega(p_\gamma^{-d'})}(A_{\omega(p_\gamma^{-d'})}) \leq B_u$$

for some $b \in B_u$ if $u \in VB$ is the terminal vertex of the \mathbb{B} -paths $u_\gamma q_\gamma^z$ for any $z \in \mathbb{Z}$. Now proceed exactly as in the case $\gamma \in C^2$ with d' instead of d , i.e. define $e_{-d'} \in \tilde{\mathbb{A}}^2$ and find $e \in E\tilde{\mathbb{A}}$ as before and glue the graphs of groups \mathbb{A}^2 and \mathbb{A}^3 together by identifying the edges e and $e_{-d'}$. Proceed in this manner for any $\gamma \in C^1$ and call the resulting graph of groups \mathbb{A}^{2d} . Let $\mathfrak{f}^{2d} : \mathbb{A}^{2d} \rightarrow \mathbb{B}$ be the associated folded graphs of groups morphism. Remind that $g_\gamma \in U$ with $(\gamma^{d'})^{g_\gamma} = \gamma^{-d'}$.

Thus it follows that there exists some closed \mathbb{A}^2 -path p starting at v_0 and some closed \mathbb{A}^3 -path starting at v'_0 such that $\mu(p) = \mu(p') = g_\gamma$ and we conclude that

$$[u][q_\gamma]^{2d}[u]^{-1} = [\underbrace{\mu(p_\gamma^{d'})}_{\mathbb{A}^2\text{-path}}] \cdot [\underbrace{\mu((p_\gamma^{-d'})^{-1} \cdot p' \cdot p_\gamma^{-d'})}_{\mathbb{A}^3\text{-path}}] \cdot [\underbrace{\mu((p_\gamma^{d'})^{-1} \cdot p^{-1})}_{\mathbb{A}^2\text{-path}}] \in \varphi_{\mathbb{F}^2}(\pi_1(\mathbb{A}^{2d}, v_0)).$$

for any $\gamma \in C^1$. Let $U_{2d} := \varphi_{\mathbb{F}^2}(\pi_1(\mathbb{A}^{2d}, v_0))$. Then it easily verified that $A_{i_j}^{g_j} \cap U_{2d} = (A_{i_j}^{g_j} \cap U) \cdot \langle (c_{i_j}^{g_j})^{2d} \rangle$ for any $c_{i_j}^{g_j} \in C$ by construction of \mathbb{A}^{2d} . Clearly $(A_{i_j}^{g_j} \cap U) \cdot \langle (c_{i_j}^{g_j})^{2d} \rangle$ is of finite index in $A_{i_j}^{g_j}$ for any j . Thus we can enlarge \mathbb{A}^{2d} such that for any j and any leftcoset representative $[q]$ of $A_{i_j}^{g_j} \cap U_{2d}$ in $A_{i_j}^{g_j}$, there exists a reduced preimage of $[q]$ in \mathbb{A}^{2d} . Since \mathbb{B} has property \mathcal{L} , there exists a cover $\mathfrak{g} : \mathbb{C} \rightarrow \mathbb{B}$ satisfying the following properties:

1. \mathfrak{f}^{2d} is almost geometric realized by \mathfrak{g} .
2. If the chosen reduced preimage p satisfying $[\mu(p)b] = [q] = g_{s'}^{-1}xg_s$ for some $b \in B_{u_0}$ is closed at v_0 for some $x \in E_{r_s} = E_{r_{s'}}$, $s \neq s'$, then $b \notin C_{v_0}$.
3. If the chosen reduced preimage p satisfying $[\mu(p)b] = g$ for some $b \in B_{u_0}$ is closed at v_0 then $b \notin C_{v_0}$ implying that $g \notin H_{2d} := \varphi_{\mathfrak{g}}(\pi_1(\mathbb{C}, v_0))$.
4. $A_{i_j}^{g_j} \cap H_{2d} = A_{i_j}^{g_j} \cap U_{2d}$ for any j .

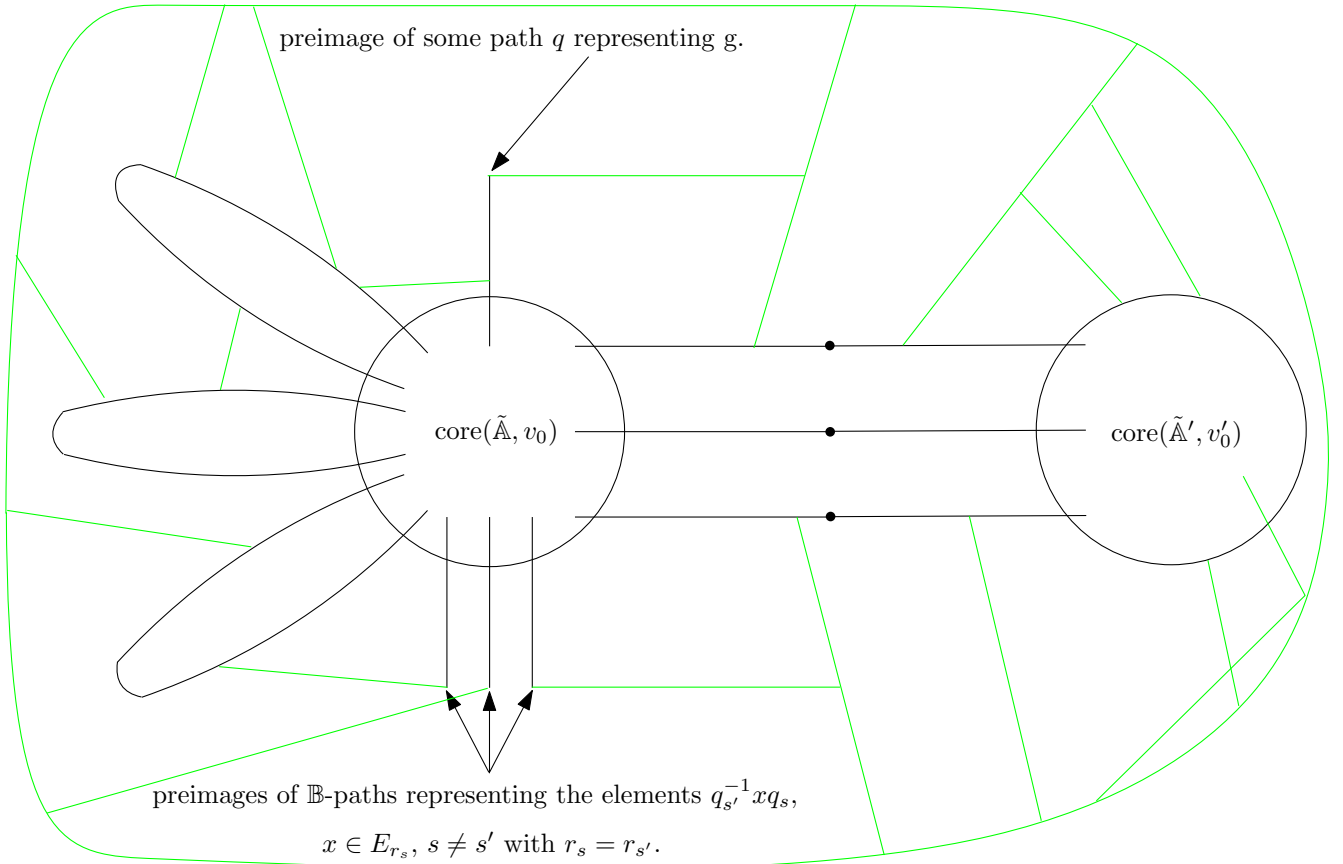

Figure 8: The graph of groups \mathbb{C} representing the finite index subgroup H_{2d} .

Note that we can make this assumptions since \mathbb{B} has property \mathcal{L} and E_r is finite for any r . If now $H_{2d} \cdot g_j^{-1} \cdot A_{i_j} = H_{2d} \cdot g_{j'}^{-1} \cdot A_{i_{j'}}$ for some $j \neq j'$ then there exists $h \in H^{2d}$ such that $(H_{2d} \cap A_{i_j}^{g_j})^h = H_{2d} \cap A_{i_{j'}}^{g_{j'}}$ by Lemma 3.63.2 and it is easily verified that this contradicts the fact that \mathfrak{f} is almost geometric realized by \mathfrak{g} . Moreover $H_{2d} \cdot g_s^{-1} \cdot E_{r_s} = H_{2d} \cdot g_{s'}^{-1} \cdot E_{r_{s'}}$ for some s, s' with $r_s = r_{s'}$ would imply that $[q] = g_s^{-1} x g_{s'} \in H_{2d}$ for some $x \in E_r$, contracting the fact that \mathbb{A} contains a reduced preimage of the path q and if this preimage is closed at v_0 , we have $b \notin C_{v_0}$ for $[\mu(p)b] = [q]$. Thus \mathfrak{g} represents the desired subgroup H_{2d} and since d was a fixed multiple of $2n$ the claim follows for n after replacing n by $4n$. \square

Lemma 4.18. *Let G be a subgroup separable group and let B be a normal virtually cyclic subgroup of G , such that any two subgroups in B are already conjugate in B whenever they are conjugate in G . Moreover let $\langle c \rangle$ be a maximal cyclic subgroup of finite index in B . Consider some subgroup $U \leq G$ and some finite set of elements $\{g_j\}$ satisfying $Bg_j^{-1}U \neq Bg_{j'}^{-1}U$ for any $j \neq j'$. Moreover let $g \in G \setminus U$. Then there exists some $m \in \mathbb{N}$ such that for any multiple d of m there exists some finite index subgroup H_d of G containing U such that the following holds:*

1. $g \notin H_d$,
2. $B \cdot g_j^{-1} \cdot H_d = g_j^{-1} \cdot B \cdot H_d \neq g_{j'}^{-1} \cdot B \cdot H_d = B \cdot g_{j'}^{-1} \cdot H_d$,
3. $B^{g_j} \cap H_d = B \cap H_d = (B \cap U) \cdot \langle c^d \rangle$,
4. $B \cap H_d^{g_j^{-1}} = (B \cap H_d)^{g_j^{-1}} = ((B \cap U) \cdot \langle c^d \rangle)^{g_j^{-1}} = ((B \cap U) \cdot \langle c^d \rangle)^b$ for some $b \in B$.

Proof: If $U \cap \langle c \rangle = \langle c^n \rangle$ for some $n \in \mathbb{N}$ let $m = n$. If $U \cap \langle c \rangle = \{1_G\}$ choose $m \in \mathbb{N}$ such that $\langle c^m \rangle$ is normal in G and $g \notin U \cdot \langle c^d \rangle \leq G$ for any multiple d of m . Note that such m exists, since we find some characteristic subgroup of finite index in $B \trianglelefteq G$, which is contained in $\langle c \rangle$. Let d be a fixed multiple of m and choose a left transversal L of the finite index subgroup $U' := U \cdot \langle c^d \rangle \cap B$ in B . Since G is subgroup separable there exists some finite index subgroup $H' \leq G$ containing U' satisfying $x \notin H'$ for any $x \in L$. Note that $g_j g_{j'}^{-1} \notin BU$ for any $j \neq j'$ since B is normal in G and $g_j^{-1} \cdot B \cdot H_d \neq g_{j'}^{-1} \cdot B \cdot H_d$. Thus using the subgroup separability of G again, we find some finite index subgroup H containing $BU \geq U'$ such that $g_j g_{j'}^{-1} \notin H$ for any $j \neq j'$. Now it is easily verified that $H_d := H' \cap H$ satisfies the required properties proving the claim. \square

Theorem 4.19. *Let \mathbb{B} be a star of groups with midpoint u_0 and let $EB^+ = \{l \in EB \mid \alpha(l) = u_0 \wedge |\alpha_l(B_l)| = \infty\}$. Assume that the following holds:*

1. *There exist $k', C' \in \mathbb{N}$ such that $B_{u_0} = \pi_1(\mathbb{B}', u'_0)$ for some (k', C') -acylindrical graph of groups \mathbb{B}' having property \mathcal{L}^+ .*
2. *Let $l \in EB$ with $\alpha(l) = u_0$. Then $\alpha_l(B_l)$ is either a finite group or $\alpha_l(B_l) = \text{Stab}_{B_{u_0}}(\text{Axis}(c_l))$ for some $c_l \in B_{u_0}$ acting properly hyperbolically on $\Gamma' = (\mathbb{B}', u'_0)$. In particular $\alpha_l(B_l)$ is virtually infinite cyclic by Corollary 4.5.*
3. *The family $(\alpha_l(B_l))_{l \in EB^+}$ is almost conjugacy separated.*
4. *Let $l \in VB$ such that $\alpha(l) = u \neq u_0$. Then B_u is subgroup separable and $\alpha_l(B_l) \trianglelefteq B_u$.*

Then \mathbb{B} is (k, C) -acylindrical and has property \mathcal{L} for some $k, C \in \mathbb{N}$. Moreover any hyperbolic element $\gamma \in \pi_1(\mathbb{B}, u_0)$ is proper.

Proof: First observe that it is an immediate consequence of Corollary 4.4 and Definition 4.11 that the assumptions imply the (k, C) -acylindricity of \mathbb{B} for some $k, C \in \mathbb{N}$. Thus by Lemma 4.13 it follows that any hyperbolic element $\gamma \in \pi_1(\mathbb{B}, u_0)$ is proper. So it's left to show that \mathbb{B} has property \mathcal{L} . For this let $f : \tilde{\mathbb{A}} \rightarrow \mathbb{B}$ be a folded morphism representing some f.g. subgroup $U \leq G = \pi_1(\mathbb{B}, u_0)$ with A finite and let $x \in B_{f(w)} \setminus f_w(A_w)$ for some fixed $w \in VA$. Clearly we can regard $\tilde{\mathbb{A}}$ as a subgraph of groups of some graph of groups $\tilde{\mathbb{A}}$ corresponding to some cover $\tilde{f} : \tilde{\mathbb{A}} \rightarrow \mathbb{B}$ representing U .

At first extend A such that for any free edge $e \in E\tilde{\mathbb{A}} \setminus EA$ satisfying $\alpha(e) = v \in VA$ it follows $f(v) = u_0$. Recall that $|VA| < \infty$. Now by applying Theorem 4.17 and Theorem 4.19 it follows that we find some $d \in \mathbb{N}$ such that for any $v \in VA$ there exists some finite index subgroup $C_v \leq B_{f(v)}$ containing $f_v(A_v)$ such that the following holds:

1. $x \notin C_v$ if $v = w$.
2. F.a. $e_1 \neq e_2 \in EA$ with $\alpha(e_1) = \alpha(e_2) = v \in VA$ and $f(e_1) = f(e_2) = l$ we have:

$$C_v g_{e_1}^\alpha \alpha_l(B_l) \neq C_v g_{e_2}^\alpha \alpha_l(B_l).$$

3. If $|f_v(A_v) : f_v(A_v) \cap g_e^\alpha \alpha_l(B_l)(g_e^\alpha)^{-1}| = \infty$ for some $e \in EA$ with $\alpha(e) = v$ and $f(e) = l$ it follows

$$C_v \cap g_e^\alpha \alpha_l(B_l)(g_e^\alpha)^{-1} = (f_v(A_v) \cap g_e^\alpha \alpha_l(B_l)(g_e^\alpha)^{-1}) \cdot (g_e^\alpha \langle c_l^d \rangle (g_e^\alpha)^{-1})$$

4. If $|f_v(A_v) : f_v(A_v) \cap g_e^\alpha \alpha_l(B_l)(g_e^\alpha)^{-1}| < \infty$ for some $e \in EA$ with $\alpha(e) = v$ and $f(e) = l$ it follows

$$C_v \cap g_e^\alpha \alpha_l(B_l)(g_e^\alpha)^{-1} = f_v(A_v) \cap g_e^\alpha \alpha_l(B_l)(g_e^\alpha)^{-1}.$$

Note that for any $v \in VA$ with $f(v) \neq u_0$ we have $f(e_1) = f(e_2) = l \in EB$ for any $e_1, e_2 \in EA$ with $\alpha(e_1) = \alpha(e_2) = v$. Moreover $C_v \cap g_e^\alpha \alpha_l(B_l)(g_e^\alpha)^{-1} = C_v \cap \alpha_l(B_l)$ for any $e \in f_v^{-1}(l)$. Define the graph of groups \mathbb{C} as follows:

1. Let $C = A$.
2. For any $v \in VA = VC$ let $C_v \leq B_{f(v)}$ be the subgroup satisfying the above conditions.
3. $C_e := (g_e^\alpha)^{-1} C_v g_e^\alpha \cap \alpha_l(B_l)$ for any $e \in EA = AC$.

It follows that we can regard $\tilde{\mathbb{A}}$ as a subgraph of groups of the graph of groups \mathbb{C} and it is easily verified that the tuple

$$\mathfrak{h} = (h = f, \{h_v = id | v \in VC\}, \{h_e = id | e \in EC\}, \{g_e^\alpha | e \in EC\}, \{g_e^\omega | e \in EC\})$$

with the same g_e^α 's and g_e^ω 's as in \tilde{f} is a **folded** morphism of graphs of groups.

Since \mathbb{B} is finite we have that $|EB| = n < \infty$. So let $\{l_1, \dots, l_n\}$ the subset of edges of EB originating at u_0 . Clearly \mathbb{C} embeds in some covering graph $\tilde{\mathbb{C}}$ and by assumption we have that for any free edge $e \in E\tilde{\mathbb{C}} \setminus EC$ with $\alpha(e) = v \in EC$ we have $\alpha(e) = u_0$. Thus for any free edge e holds $f(e) = l_i$ for some $i \in \{1, \dots, n\}$.

Hence it follows that for any $i \in \{1, \dots, n\}$ there exists some finite set of finite index subgroups $A_i^1, \dots, A_i^{m_i}$ of B_{l_i} for some $m_i \in \mathbb{N}$ such that for any free edge $e \in E\tilde{\mathbb{C}}$ with $f(e) = l_i$ we have that $h_e(C_e)^b = A_i^j \leq B_{l_i}$ for some $b \in B_{l_i}$ and $j \in \{1, \dots, m_i\}$. We say that e is of type A_i^j . Since C is finite it follows that there exists $k_1^1 \in \mathbb{N}$ such that there are exactly k_1^1 free edges of type A_1^1 . Now start with the finite index subgroup A_1^1 of B_{l_1} and apply Lemma 4.18 to $\omega_{l_1}(A_1^1) \leq B_{\omega(l_1)}$. By doing this, we receive a finite index subgroup $\tilde{A}_1^1 \leq B_{\omega(l_1)}$ such that for any $g \in B_{\omega(l_1)}$ it follows $(\tilde{A}_1^1)^g \cap \omega_{l_1}(B_{l_1}) = \omega_{l_1}(A_1^1)$ therefore the covering piece $\tilde{\mathbb{A}}_1^1$ corresponding to \tilde{A}_1^1 has the shape of a star (see Remark 3.82). So let v be the midpoint of this covering piece. Thus $A_v = \tilde{A}_1^1$ and it follows that any free edge starting at v is of type A_1^1 and since \tilde{A}_1^1 is of finite index in $B_{\omega(l_1)}$ it follows that there exists $r_1^1 \in \mathbb{N}$ such that there are exactly r_1^1 free edges starting at v and all of these are of type A_1^1 .

By proceeding as in Construction 3.83, we can glue k_1^1 copies of $\tilde{\mathbb{A}}_1^1$ to r_1^1 copies of \mathbb{C} to receive a graph of groups \mathbb{C}_1^1 which satisfies:

1. \mathbb{C} is a subgraph of groups of \mathbb{C}_1^1 .
2. \mathbb{C}_1^1 is finite and contains only free edges of type A_i^j with $j \neq 1$ if $i = 1$.

Proceeding in this manner for any A_i^j we receive after finitely many construction steps the graph of groups $\mathbb{C}_n^{m_n}$ satisfying:

1. $\mathbb{C}_n^{m_n}$ is finite and there exists a covering $\mathfrak{h}^{n, m_n} : \mathbb{C}_n^{m_n} \rightarrow \mathbb{B}$.
2. \mathfrak{h} is geometric realized by $\mathfrak{h}_n^{m_n}$
3. $x \notin (C_n^{m_n})_w$.

Note the first three construction steps will be illustrated in figure 9 on the next page. We conclude that \mathbb{B} has property \mathcal{L} proving the claim. \square

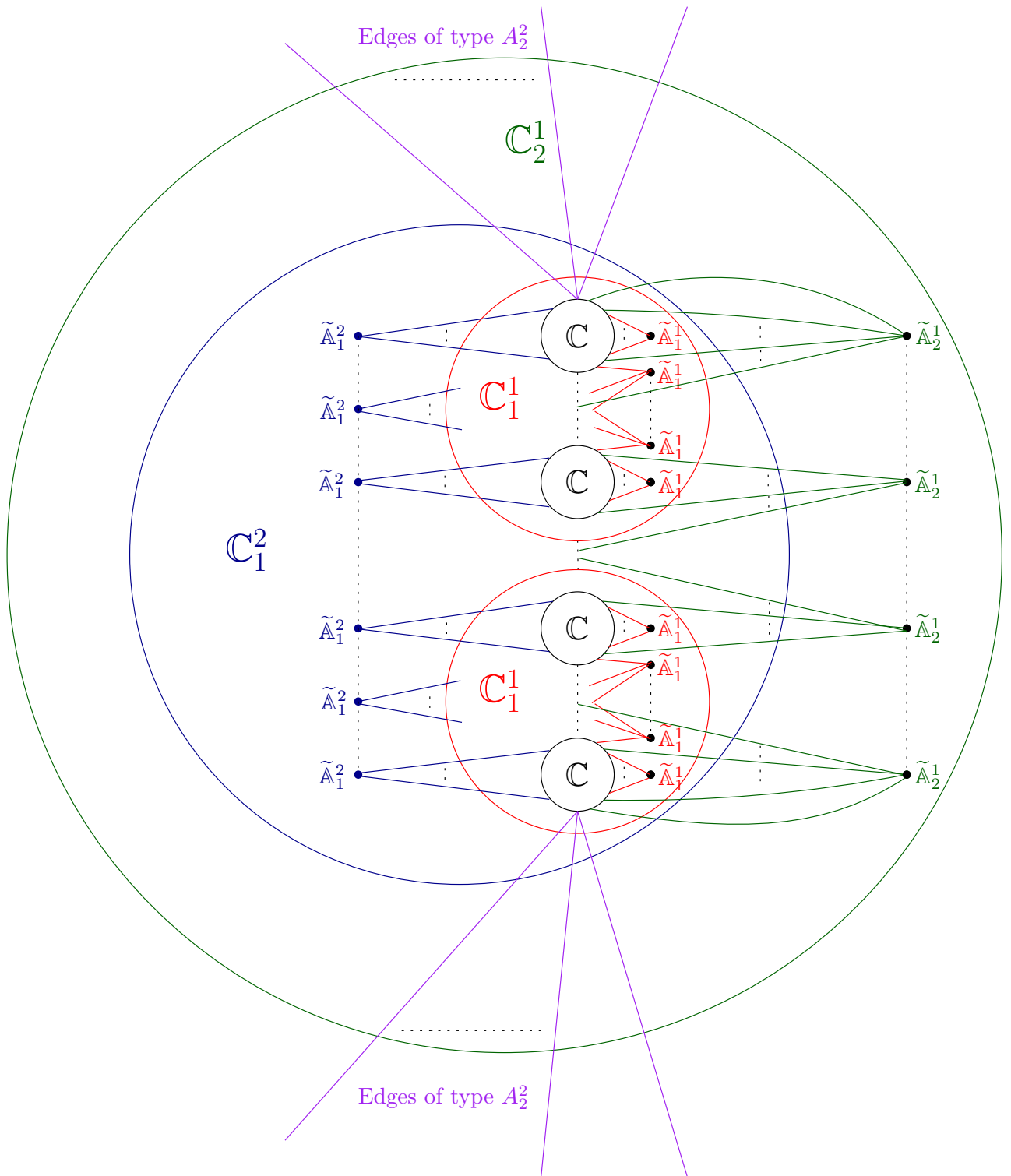

Figure 9: The picture illustrates the first three construction steps on the way constructing the covering graph of groups $\mathbb{C}_n^{m_n}$.

4.3 Towers of (k, C) -acylindrical stars of groups with certain "midpoint"-vertex groups

We are now able to prove the main result of this chapter. The proof will be by induction, while Theorem 4.17 provides the inductive step.

Definition 4.20. *We call a finite sequence of graphs of groups, $\mathbb{B}^1, \dots, \mathbb{B}^n$, $n \in \mathbb{N}$, a tame tower over the f.g. virtually free group G if the following holds:*

1. \mathbb{B}^0 is a finite graph of finite groups satisfying $\pi_1(\mathbb{B}^0, u_0) = G_0 = G$ for some $u_0 \in VB^0$.
2. \mathbb{B}^i , $0 < i \leq n$, is a finite star of groups with midpoint $m^i \in VB^i$ satisfying the following conditions:
 - (a) $B_{m^i}^i = \pi_1(\mathbb{B}^{i-1}, u_0)$ for some $u_0 \in VB^{i-1}$.
 - (b) Let $l \in EB^i$ originating at m^i . Then $\alpha_l(B_l^i)$ is either a finite group or $\alpha_l(B_l^i) = \text{Stab}_G(\text{Axis}(\gamma))$ for some hyperbolic loop $\gamma \in B_{m^i}^i = \pi_1(\mathbb{B}^{i-1}, u_0)$, $u_0 \in VB^{i-1}$. Moreover $B_{\omega(l)}^i$ is subgroup separable and contains only finitely many conjugacy classes of finite groups such that the embedded subgroup $B := \omega_l(B_l^i)$ is normal in $B_{\omega(l)}^i$ satisfying that any two subgroups in B are already conjugate in B whenever they are conjugate in $B_{\omega(l)}^i$.
 - (c) Let $EB^{i,+} := \{l \in EB^i \mid \alpha(l) = m^i \wedge |\alpha_l(B_l^i)| = \infty\}$. Then the family $(\alpha_l(B_l^i))_{l \in EB^{i,+}}$ is almost conjugacy separated for any $i \leq n$.

For any $u_0 \in VB^n$ we call the group $H = \pi_1(\mathbb{B}^n, u_0)$ a tame tower extension of the virtually free group G .

Remark 4.21. *Note that any finite subgroup E of the fundamental group G of a finite graph of groups \mathbb{B} acts elliptic on the corresponding Bass-Serre implying that E is conjugate to some subgroup of some vertex group of \mathbb{B} . It follows that the group G has finitely many conjugacy classes of finite groups if and only if any vertex group of \mathbb{B} fulfills this property. Since any f.g. virtually free group splits as finite graph of finite groups by Theorem 3.93 it follows that any f.g. virtually free group contains only finitely many conjugacy classes of finite groups. \square*

Theorem 4.22. *Let $n \in \mathbb{N}$ and $\mathbb{B}^1, \dots, \mathbb{B}^n$ be a tame tower over the virtually free group G . Then \mathbb{B}^n has property \mathcal{L}^+ . In particular any tame tower extension H of a virtually free group G is subgroup separable.*

Proof: As mentioned the proof follows by an easy induction. If $n = 0$ the statement follows by Theorem 4.17 since any virtually free group is subgroup separable by Theorem 3.93 and any finite graph of finite groups satisfies the required assumptions for applying Theorem 4.17. So let $n \geq 1$ and assume that \mathbb{B}^{n-1} has property \mathcal{L}^+ . First of all note that by Remark 4.21 we can assume by induction that the fundamental group of \mathbb{B}^i has only finitely many conjugacy classes of finite groups for any $i \leq n - 1$ and therefore the fundamental group of \mathbb{B}^n fulfills this property as well. Moreover an easy inductive argument shows that for any $i \leq n$ any element $\gamma \in \pi_1(\mathbb{B}^i, u_0)$, $u_0 \in VB^i$, acting hyperbolically on $\widetilde{(\mathbb{B}^i, u_0)}$ is proper by Lemma 4.9 combined with Lemma 4.13. So we are able to apply Theorem 4.19 to \mathbb{B}^n implying that \mathbb{B}^n has property \mathcal{L} which is equivalent to the fact that the fundamental group of \mathbb{B}^n is subgroup separable by Theorem 3.76. Applying Theorem 4.17 to \mathbb{B}^n provides now that \mathbb{B}^n has property \mathcal{L}^+ proving the claim. \square

4.4 Towers of iterated virtual extensions of centralizers

Towers of iterated extensions of centralizers play an important role in the theory of limit groups. We will generalize the definitions to "towers of iterated **virtual** extensions of centralizers", which may play an important role in theory of Γ -limit groups if Γ is an arbitrary (hyperbolic) group. Note that we will restrict us to the case where the base group Γ is a f.g. virtually free group. In this situation Theorem 4.22 enables us to show the subgroup separability for some kind of towers over Γ . We start with some basic definitions.

Definition 4.23. *Let G be a group and $A \leq G$. We say A has property \mathcal{C} , if A is maximal virtually abelian and A contains a maximal cyclic subgroup of G of finite index.*

Definition 4.24. *[Virtual extension of a centralizer] Let G be a group. Suppose that for some $x \in G$ the centralizer $C := C_G(x)$ is abelian and let $D \leq G$ such that D is maximal virtually abelian and D is virtually C . Moreover let A be a group such that there exists an injective homomorphism $\psi : D \rightarrow A$ and $A = \psi(D) \times A'$ with $A' \cong \mathbb{Z}^n$, $n \in \mathbb{N}$. We call the amalgamated product*

$$G(x, A) := G *_{D=\psi(D)} A$$

a virtual extension of the centralizer of x by A with respect to ψ . We call a virtual extension of centralizer special, if the group D has property \mathcal{C} .

Definition 4.25. *[(Special) iterated virtual extension of a centralizer] Let G be a group. A **(special) iterated virtual extension of centralizers over G** is a group H for which there exists a finite series*

$$G \cong G_0 \leq G_1 \leq \dots \leq G_k \cong H$$

*such that for $i = 0, \dots, k-1$, each G_{i+1} is a (special) virtual extension of a centralizer of G_i . We call H a **IVCE-group** of level k or a **SIVCE-group** of level k , accordingly.*

Our aim is to show that any SIVCE-group H over some f.g. virtually free group G is subgroup separable by applying Theorem 4.22. The next two statements provide that any such H is a tame tower extension over the corresponding virtually free group G .

Lemma 4.26. *Let H be a SIVCE-group over some f.g. virtually free group G then there exists $n \in \mathbb{N}$ and a sequence graphs of groups \mathbb{B}^i , $i \in \{0, \dots, n\}$, such that the following holds:*

1. \mathbb{B}^0 is a finite graph of finite groups satisfying $\pi_1(\mathbb{B}, u_0) = G_0 \cong G$ for some $u_0 \in VB$.
2. $H \cong G^n = \pi_1(\mathbb{B}^n, u_0)$ for some $u_0 \in VB^n$.
3. \mathbb{B}^i , $0 < i \leq n$, is a finite star of groups with midpoint $m^i \in VB^i$ satisfying the following conditions:
 - (a) $B_{m^i}^i = \pi_1(\mathbb{B}^{i-1}, u_0)$ for some $u_0 \in VB^{i-1}$.
 - (b) Let $l \in EB^i$ originating at m^i . Then $\alpha_l(B_l^i)$ is either finite or $\alpha_l(B_l^i) = \text{Stab}_G(\text{Axis}(\gamma))$ for some hyperbolic loop $\gamma \in B_{m^i}^i = \pi_1(\mathbb{B}^{i-1}, u_0)$ and $B_{\omega(l)}^i = \omega_l(B_l^i) \times \mathbb{Z}^r$ for some $r \in \mathbb{N}$.

(c) Let $EB^{i,+} := \{l \in EB^i \mid \alpha(l) = m^i \wedge |\alpha_l(B_l^i)| = \infty\}$. Then the family $(\alpha_l(B_l^i))_{l \in EB^{i,+}}$ is almost conjugacy separated for any $i \leq n$.

Proof: The proof is by induction on level. If $k = 1$ the claim is obvious. So assume that $k > 1$ and let $G_k = G_{k-1} *_{D_k = \psi(D_k)} A_k$. By induction hypothesis we can assume that G_{k-1} satisfies the desired conditions. Thus there exists $n \in \mathbb{N}$ such that $G_{k-1} = \pi_1(\mathbb{B}^n, u_0)$ for some star of groups \mathbb{B}^n and some base point $u_0 \in VB^n$.

If $D_i = \text{Stab}_G(\text{Axis}(\gamma))$ s.t. γ acts hyperbolically on (\mathbb{B}^n, u_0) the claim is obvious since any amalgamated product can be regarded as a graph of groups with two vertices and one edge. So assume that D_i acts elliptic on (\mathbb{B}^n, u_0) . Since D_k has property \mathcal{C} it follows that D_k cannot be conjugate into $B_{\omega(l)}^i \setminus \omega_l(B_l^i)$ with $\alpha(l) = m^i$ for some $l \in EB^i$, $i \leq n$. We distinguish two cases:

1. If D_k is infinite it is easily verified that we can find some $i < n$, some $h \in G_{k-1}$ and some $\gamma \in D_k$ such that γ^h acts hyperbolically on (\mathbb{B}^{i-1}, u_0) for some chosen basepoint $u_0 \in VB^{i-1}$. W.l.o.g. assume that $\gamma^h = \gamma$. Then it follows by Corollary 4.5 that $D_k = \text{Stab}_G(\text{Axis}(\gamma))$ since the inductive hypothesis implies that \mathbb{B}^{i-1} is (k, C) -acylindrical by Theorem 4.19. Thus one of the following holds:
 - (a) There exists some $l \in EB^i$ originating at m^i such that $D_k^g = \alpha_l(B_l^i)$ for some $g \in \pi_1(\mathbb{B}^{i-1}, u_0)$. Then it is easily verified that extending the rank of the free abelian subgroup in $B_{\omega(l)}^i$ in the obvious way leads to a group isomorphic to G_k .
 - (b) Assume that for any $l \in EB^i$ with $\alpha(l) = m^i$ and any $g \in \pi_1(\mathbb{B}^{i-1}, u_0)$ holds $|D_k^g \cap \alpha_l(B_l^i)| < \infty$. Then we extend \mathbb{B}^i by adding a new edge l' to EB^i such that $\alpha_{l'}(B_{l'}^i) = D_k$, $\omega_{l'}(B_{l'}^i) = \psi(D_k)$ and $B_{\omega(l')}^i = A_k$. Again this proves the claim since by doing this we receive a group isomorphic to G_k .
2. If D_k is finite it is easily verified that there exists some $h \in G_{k-1}$ such that D_k^h is a subgroup of the base group G , which is virtually free. Now the claim follows by distinguishing the same two cases as before for \mathbb{B}^1 and by proceeding as in these cases. \square

Remind that in order to apply Theorem 4.22 we still need to show that any vertex group of the graph of groups \mathbb{B}_i , $i \leq n$, contains only finitely many conjugacy classes of finite groups. By Remark 4.21 it suffices to prove the following to arrange this:

Lemma 4.27. *Any f.g. virtually abelian group A has only finitely many conjugacy classes of finite groups.*

Proof: Let A be f.g. virtually abelian group. If A is finite, the result is trivial, so we may assume that A is infinite. Thus A contains some free abelian normal subgroup $Z \cong \mathbb{Z}^r$, $r \in \mathbb{N}$, of finite index, say n . Then for any finite subgroup E the subgroup $E \cdot Z \leq A$ splits as a semidirect product of the groups E and Z implying that $|E| \leq n$. Therefore we find some finite subset of finite subgroups F_1, \dots, F_k such that for any $E \leq A$ we have $E \cong F_i$ for some $i \in \{1, \dots, k\}$. So it suffices to show that A contains only finitely many conjugacy classes of finite isomorphic subgroups. So let $E_1, E_2 \leq A$ be two finite isomorphic subgroups of order m and let $\phi : E_1 \rightarrow E_2$ be an isomorphism. Then $E_1 Z$ and $E_2 Z$ are two of only finitely many finite index subgroups containing Z , since A/Z is finite. So w.l.o.g. we may assume $A = E_1 Z = E_2 Z$.

Consider the injective endomorphism $\varphi : Z \rightarrow Z; z \mapsto z^m$ with $m = |E_1| = |E_2|$. Obviously $Z' := \varphi(Z)$ is a characteristic subgroup of index r^m in Z and therefore Z' is a normal subgroup of finite index in A . Let X be a transversal of Z' in Z . Then $E_i X$, $i \in \{1, 2\}$, is a transversal of Z' in A . It is easily verified that there exists a bijective map $\psi : E_1 X \rightarrow E_2 X$ satisfying $\psi(e \cdot x)Z' = e \cdot xZ'$ for any $e \in E_1$ and $x \in X$ such that $\psi|_{E_1} = \phi$. Now by assuming that $1_A \in X$ it follows $\psi(e)Z' = eZ'$ for any $e \in E_1$. Furthermore since $Z' \leq Z$ is abelian and $\psi(e)^{-1}e \in Z'$ we can define unambiguously the element $\tilde{z} := \prod_{e \in E_1} \psi(e)^{-1}e \in Z'$. Again as $Z' \leq Z$ is abelian it follows for any $f \in E_1$:

$$\psi(f)^{-1}\tilde{z}\psi(f) = \prod_{e \in E_1} \psi(f)^{-1}\psi(e)^{-1}e\psi(f) = \prod_{e \in E_1} \underbrace{\psi(ef)^{-1}ef}_{\in Z'} \underbrace{f^{-1}\psi(f)}_{\in Z'} = \tilde{z} \cdot (f^{-1}\psi(f))^m.$$

Thus since φ is injective there exists some unique $z \in \mathbb{Z}$ such that $\varphi(z) = z^m = \tilde{z}$ and therefore the above equation implies

$$(\psi(f)^{-1}z\psi(f))^m = \psi(f)^{-1}\tilde{z}\psi(f) = \tilde{z} \cdot (f^{-1}\psi(f))^m = (zf^{-1}\psi(f))^m.$$

Again by injectivity of ϕ it follows $\psi(f)^{-1}z\psi(f) = zf^{-1}\psi(f)$ for all $f \in E_1$ implying that $zfz^{-1} = \psi(f)$. We conclude that $zE_1z^{-1} = \psi(E_1) = E_2$ proving the claim. \square

So we deduce the following:

Corollary 4.28. *Let G be a f.g. virtually free group and let H be an iterated virtual extension of centralizer over G . Then H contains only finitely many conjugacy classes of finite groups.* \square

Consequently any SIVCE-group H over a f.g. virtually free group G is a tame tower extension over G . Thus we conclude by applying Theorem 4.22:

Theorem 4.29. *Any SIVCE-group H over some f.g. virtually free group G is subgroup separable.* \square

Although we are not disposed to give some explicit definition of a Γ -Limit group in this work, note that in [22] the authors proved that G is a Γ -Limit group for some f.g. free group Γ if and only if G is a subgroup of a so called ICE-group over some f.g. free group. Note that the definition of an ICE-group and the definition of an IVCE-group coincides, if Γ is free. Following 1.12-1.14 in [45] one can assume that this IVCE-group is already an SIVCE-group. So this leads to the conjecture that any Γ -Limit Group H over a f.g. virtually free group Γ embeds into a SIVCE-group over a f.g. virtually free group and therefore embeds into a tame tower extension over some f.g. virtually free group. Hence Theorem 4.29 would imply that any Γ -Limit Group of this type is subgroup separable, as any subgroup of a subgroup separable group is subgroup separable. Anyway, we will not discuss this problem any further in this thesis.

5 Virtually free groups are SCS

5.1 Con-Separability

We recall now the con-serability property introduced in [3], which will be very useful to give some proofs for the SCS-property for some classes of groups. In order to explain how to use the con-separability for proving the SCS-property for some classes of groups by the way we will introduce another separability property, the so called "conjugacy distinguishability", which the authors of [8] and [9] used for establishing the SCS-property for some classes of groups and we will point out the connection of this property and the con-separability.

Definition 5.1. *Let G be a group.*

1. *Let H_1 and H_2 be finitely generated subgroups of G . We say that H_1 is con-separated from H_2 within G if there is a finite index subgroup $D \leq G$ containing H_1 such that H_2 is not conjugate into D . We call D a witness of separation.*
2. *We call H_1 con-separated in G if H_1 is con-separated from any finitely generated subgroup $H_2 \leq G$ that is not already conjugate into H_1 .*

Note that being con-separated is not a symmetric relation. In [2] the authors used the so called SICS-property to establish the SCS-property for some special virtually free groups:

Definition 5.2. *Let G be a group. G is called subgroup into conjugacy separable (SICS) if for any two f.g. subgroups H_1 and H_2 satisfying that H_2 is not conjugate into H_1 there exists a finite quotient of G such that the image of H_2 is not conjugate into the image of H_1 .*

In the last few years there have been two different task groups working independently from each other on establishing the SCS-property for different classes of groups. Namely K. Bux and O. Bogopolski, see [2], [3] and [8] aswell as P. A. Zalesskii, S. C. Chagas and L. Ribes, see [9], [33] and [12]. Latter used the following equivalent definition to the con-separability.

Definition 5.3. *Let G be a group and let H be a f.g. subgroup of G .*

1. *We call H into conjugacy distinguished in G if for any f.g. subgroup K not conjugate into H there exists a finite quotient of G where the image of K is not conjugate into the image of H .*
2. *We call G (infinite) into conjugacy distinguished if any f.g. (infinite) subgroup of G is into conjugacy distinguished.*

The following easy Lemma provides the equivalence of these two notions.

Lemma 5.4. *Let H_1, H_2 be f.g. subgroups of a group G . Then the following conditions are equivalent:*

- (1) *H_1 is con-separated from H_2 within G ,*
- (2) *There exists a homomorphism from G onto a finite group \bar{G} such that the image of H_2 is not conjugate into the image of H_1 .*

Proof: (1) \Rightarrow (2): Let D be the witness of con-separation for H_1 from H_2 . Then D contains a finite index subgroup N , which is normal in G . Obviously, the image of H_2 in G/N is not conjugate into the image of H_1 in G/N .

(2) \Rightarrow (1): If $\varphi : G \rightarrow \bar{G}$ is the homomorphism from (2), then $D := H_1 \cdot \ker\varphi$ is the witness of con-separation for H_1 from H_2 . \square

For completeness we observe the following statement.

Corollary 5.5. *Let G be a group.*

1. *A f.g. subgroup H of G is con-separated in G if and only if H is conjugacy distinguished in G .*

2. *G is subgroup into conjugacy separable if and only if G is conjugacy distinguished.*
 \square

The following Lemma, proven in [3], enables us to push the con-separability within a finite index subgroup to the con-separability within the whole group.

Lemma 5.6. *Let G' be a finite index subgroup of the group G and let H_1 and H_2 be two finitely generated subgroups of G' . Let g_1, \dots, g_k be a set of representatives for the left cosets G' in G . Assume that H_1 is con-separated from $H_2^{g_i}$ in G' for each i whenever $H_2^{g_i}$ is a subgroup of G' . Then H_1 is con-separated from H_2 in G . In particular, if H_1 is con-separated in G' it is also con-separated in G .*

Proof: If $H_2^{g_i}$ is contained in G' , let $D_i \leq G'$ be a witness of con-separation for H_1 from $H_2^{g_i}$ within G' . Otherwise, put $D_i := G'$. Note that in either case, $H_2^{g_i}$ is not conjugate into D_i by a conjugating element of G' . We claim that H_1 is con-separated from H_2 within G with witness $D := D_1 \cap \dots \cap D_k$. For contradiction, assume $H_2^g \leq D$ for some $g \in G$. We write $g = g_i h$ for some $h \in G'$. Then $H_2^{g_i h} \leq D \leq D_i$ implying that $H_2^{g_i} \leq D_i^{h^{-1}}$. Thus $H_2^{g_i}$ is conjugate into D_i by $h^{-1} \in G'$. This is a contradiction. \square

5.2 Chain Condition

Definition 5.7. *We say that an automorphism $\alpha \in \text{Aut}(G)$ of the group G is expanding if there is a finitely generated subgroup $H \leq G$ such that $H < H^\alpha$ is a strict inclusion.*

Not every group admits expanding automorphisms. E.g., the following result [41] of Takahasi implies that free groups of finite rank do not.

Theorem 5.8. *Let*

$$H_1 < H_2 < H_2 < \dots \leq F_n$$

be a strictly ascending infinite chain of finitely generated subgroups of the finitely generated free group F_n . The sequence of ranks of free groups H_i is unbounded. \square

In [3] it is shown, that we can promote Takahasi's Theorem to surface groups. For completeness we repeat the proof.

Proposition 5.9. *Let S be a compact surface and let*

$$H_1 < H_2 < H_2 < \dots \leq \pi_1(S)$$

be a strictly ascending infinite chain of finitely generated subgroups. Then the groups H_i are free and the sequence of their ranks is unbounded.

Proof: If S is not closed, i.e. a surface with boundary, then $N = \pi_1(S)$ is a f.g. free group, since S is compact. Thus the statement follows directly from Theorem 5.8. So assume that S is closed. Note that the ascending union $H := \cup_i H_i$ cannot be finitely generated as the sequence is strictly ascending. In particular H has infinite index in $\pi_1(S)$ and is free of countable rank. Thus we can embed H as a subgroup of F_2 to receive the strictly ascending sequence

$$H_1 < H_2 < H_3 < \dots \leq F_2$$

and the claim follows again from Theorem 5.8. \square

Lemma 5.10. *Let G be a group and N a finite index subgroup of G , such that N does not admit expanding automorphisms.*

1. *If N is characteristic in G , then G does not admit expanding automorphisms.*
2. *If N is normal in G , then G does not admit expanding inner automorphisms.*

Proof: So let N be a subgroup of finite index in G , which does not admit expanding inner automorphisms.

1. Assume that N is characteristic in G . If $\alpha \in \text{Aut}(G)$ would be an expanding automorphism on a subgroup $H \leq G$, we would have the ascending chain

$$H < H^\alpha < H^{\alpha^2} < \dots$$

Since N is of finite index in G the ascending chain

$$H \cap N \leq H^\alpha \cap N \leq H^{\alpha^2} \cap N \leq \dots \leq N$$

has a strictly ascending subchain

$$H \cap N < H^{\alpha^{k_1}} \cap N < H^{\alpha^{k_2}} \cap N < \dots \leq N$$

for some $k_i \in \mathbb{N}$ for all $i \in \mathbb{N}$. Since N is characteristic in G , we conclude that $H^{\alpha^k} \cap N = (H \cap N)^{\alpha^k}$ for any $k \in \mathbb{N}$, contradicting that N does not admit expanding automorphisms.

2. The proof of the second assertion is similar, except that we are in the situation where $N \trianglelefteq G$ and $\alpha \in \text{Inn}(G)$. \square

Corollary 5.11. *Let S be compact surface and let G virtually $\pi_1(S)$. Then G does not admit expanding inner automorphisms.*

Proof: Let G be such a group. Then there exists a subgroup N of finite index in G with $N = \pi_1(S)$ for some compact surface S . W.l.o.g. we can assume that N is normal in G . By Lemma 5.10 it suffices to prove that N does not admit expanding automorphisms. If $\alpha \in \text{Aut}(N)$ would be an expanding automorphism on a subgroup $H \leq N$, we would have the ascending chain

$$H < H^\alpha < H^{\alpha^2} < \dots \leq N$$

Since $\alpha \in \text{Aut}(N)$ it follows that all groups in the chain are isomorphic implying that their free ranks coincide, contradicting Proposition 5.9. \square

Since any f.g. free group can be regarded as the fundamental group of a compact surface with boundary we observe the following:

Corollary 5.12. *Let G be a f.g. virtually free group. Then G admits no expanding inner automorphisms.* \square

The following statement implies that for any totally orientable Seifert fibered space M , $\pi_1(M)$ does not admit expanding inner automorphisms:

Lemma 5.13. *Consider the short exact sequence of groups*

$$1 \rightarrow C \xrightarrow{\psi} G \xrightarrow{\varphi} H \rightarrow 1$$

such that C does not admit expanding automorphisms and H does not admit expanding inner automorphisms. Then G has no expanding inner automorphisms.

Proof: W.l.o.g. we identify C with $\psi(C)$. Let $S \leq G$ and assume that there exists $g \in G$ such that $S \not\leq S^g$. By assumption H has no inner expanding automorphisms. So we deduce that $\varphi(S) = \varphi(S)^{\varphi(g)} = \varphi(S^g)$. Therefore $S \cdot C/C = S^g \cdot C/C$. Moreover we have that $S \cap C \leq S^g \cap C$. Since $C = \ker \varphi$ is normal in G , $S \cap C \not\leq S^g \cap C = (S \cap C)^g$ contradicts the assumption that C has no expanding automorphisms. So assume that $S \cap C = S^g \cap C$. Then we deduce $S/S \cap C \leq S^g/S \cap C = S^g/S^g \cap C$. Considering the natural isomorphism $\tau : S^g/S^g \cap C \rightarrow S^g \cdot C/C$ we conclude

$$\varphi(S) = SC/C = \tau(S/S \cap C) = \tau(S/S^g \cap C) \leq \tau(S^g/S^g \cap C) = S^gC/C = \varphi(S^g).$$

A contradiction. Thus the statement is proven. \square

We close this chapter with the following useful statements of [2]:

Lemma 5.14. *Let H_1 and H_2 be two finitely generated subgroups of a group G . Assume that G does not admit expanding inner automorphisms. If H_1 conjugates into H_2 and H_2 conjugates into H_1 , then H_1 and H_2 are conjugate. More precisely, for any two elements $g, h \in G$ with $H_2^g \leq H_1$ and $H_1^h \leq H_2$ one already has equality: $H_2^g = H_1$ and $H_1^h = H_2$*

Proof: We have $H_1 \leq H_2^{h^{-1}} \leq H_1^{g^{-1}h^{-1}}$. Put $f := g^{-1}h^{-1}$ and consider the associated inner automorphism. Since it is not expanding, the inclusion $H_1 \leq H_1^f$ is not strict. Hence $H_1 = H_1^f$ that implies $H_1^h = H_2^g = H_1$. \square

This statement produces the following crucial corollary, which will enable us to deduce the SCS-property from the con-separability if the considered group G does not admit expanding inner automorphisms.

Corollary 5.15. *Suppose that a group G does not admit expanding inner automorphisms and let H_1 and H_2 be two non-conjugate finitely generated subgroups of G . Then H_1 is not conjugate into H_2 or H_2 is not conjugate into H_1 .* \square

5.3 Fully conjugacy separable groups

It seems reasonable, that the conjugacy separability is related to the conjugacy separability. And it turns out, that the cs-property is an important tool for proving the subgroup conjugacy separability. Remind that a group G is said to be conjugacy separable (CS) if for any pair of non conjugate elements $a, b \in G$, there exists a homomorphism φ from G to a finite group E such that $\varphi(a)$ and $\varphi(b)$ are not conjugate within E . In the following definition we extend this property to finite subsets of G :

Definition 5.16. *A group G is called fully conjugacy separable (FCS) if for any two finite subsets $A, B \subseteq G$ with a not conjugated to b for any $a \in A$ and $b \in B$, there exists a homomorphism φ from G to a finite group E , such that $\varphi(a)$ is not conjugate to $\varphi(b)$ in E for any pair of elements $a \in A, b \in B$.*

It is easy to see that fully conjugacy separable implies conjugacy separable. The following Lemma shows that the converse is also true:

Lemma 5.17. *A group G is conjugacy separable if and only if it is fully conjugacy separable.*

Proof: We have to show that the conjugacy separability implies the fully conjugacy separability, since the other implication is obvious. So let G be CS and $A, B \subseteq G$ two finite subsets, such that no element of A is conjugate to an element of B . Since G is CS, for any pair $a \in A, b \in B$ there exists a finite group $E_{a,b}$ and a homomorphism $\varphi : G \rightarrow E_{a,b}$ such that the images of a and b are not conjugate in $E_{a,b}$. These homomorphisms induce a homomorphism

$$\varphi := \prod_{a \in A, b \in B} \varphi_{a,b} : G \rightarrow \prod_{a \in A, b \in B} E_{a,b}.$$

Clearly $E := \prod_{a \in A, b \in B} E_{a,b}$ is finite as $n = |A| \cdot |B|$ is finite. Moreover we have that $(e_1, \dots, e_n)^{(x_1, \dots, x_n)} = (f_1, \dots, f_n)$ in E if and only if $e_i^{x_i} = f_i$. Therefore $\varphi : G \rightarrow E$ is the desired homomorphism. \square

Lemma 5.18. *Let G be a group, B a subgroup and A a subset of G . Then the following statements are equivalent:*

- (1) *There exists a finite index subgroup D of G containing B such that any $a \in A$ is not conjugate into D .*
- (2) *There exists a homomorphism φ from G to a finite group E such that $\varphi(a)$ is not conjugate into $\varphi(B)$ in E for any $a \in A$.*

Proof: (1) \Rightarrow (2): Consider the finite index normal subgroup $N := \bigcap_{g \in G} D^g$ and the associated homomorphism $\varphi : G \rightarrow G/N$. Assume $\varphi(a)^{\varphi(g)} \in \varphi(B)$ for some $a \in A$ and $g \in G$. Then $a^g \in \varphi^{-1}(\varphi(B)) = B \cdot N \leq D$. A contradiction. Hence φ is the desired homomorphism.

(2) \Rightarrow (1): Clearly $N := \ker \varphi$ is a normal finite index subgroup of G . Assume $a^g \in D := B \cdot N$ for some $a \in A$ and $g \in G$. Then $\varphi(a^g) = \varphi(a)^{\varphi(g)} \in \varphi(B \cdot N) = B \cdot N/N = \varphi(B)$. A contradiction. Therefore D is the required subgroup of finite index containing B . \square

Corollary 5.19. *Let G be a conjugacy separable group. Then any **finite** subgroup B of G is con-separated from each element g not conjugate into B .*

Proof: By Lemma 5.17 G is FCS. Hence there exists a homomorphism φ from G to a finite group E , such that $\varphi(g)$ is not conjugate into $\varphi(B)$. Hence the claim follows immediately from Lemma 5.18. \square

In order to give a short proof that any finite subgroup of a group G containing some conjugacy separable subgroup of finite index is con-separated in G , we need the well known terminology of "twisted conjugacy classes":

Lemma and Definition 5.20. *Let G be a group and ϕ an automorphism of G . We call $g_1, g_2 \in G$ twisted- ϕ conjugate in G and write $g_1 \sim_\phi g_2$ if there exists some $g \in G$ such that $\phi(g)g_1g^{-1} = g_2$. Then \sim_ϕ defines an equivalence relation on the set of elements of G and we call this relation "twisted- ϕ conjugacy" with "twisted- ϕ conjugacy classes". We denote the twisted- ϕ conjugacy class of an element $g \in G$ by $[g]_\phi$.*

Lemma and Definition 5.21. *Let G be a group and ϕ an automorphism of G . We call ϕ virtually inner if ϕ^n is inner for some integer n . Given a virtually inner automorphism, ϕ , let $G*_\phi$ denote the group*

$$\langle G, t : t^n = x, g^t = \phi(g), \text{ for all } g \in G \rangle$$

where n is chosen to be the least integer such that ϕ^n is inner and $x \in G$ is chosen so that $\phi^n(g) = g^x$ for all $g \in G$. This group has G as a normal subgroup of finite index.

In [25], proposition 3.5, the author proved the following:

Lemma 5.22. *Let G be a conjugacy separable group and ϕ be a virtually inner automorphism of G . If G_ϕ is conjugacy separable then twisted- ϕ conjugacy classes in G are closed in the profinite topology of G .*

Proof: Note that G is a finite index subgroup of G_ϕ , so a subset of G is closed in the profinite topology of G if and only if it is closed in the profinite topology of G_ϕ . Now consider the element tg , for $g \in G$. Since $(tg)^t = gt = (tg)^{g^{-1}}$ and $ht = t\phi(h)$ for any $h \in G$ it is easily verified that every conjugate of tg is a conjugate of tg by some element of G . Moreover, if $x \in G$ then,

$$xtgx^{-1} = t(\phi(x))gx^{-1}.$$

Hence the conjugacy class of tg in G_ϕ is equal to

$$t([g]_\phi),$$

where the twisted- ϕ conjugacy class is understood to be in G . Now, since group multiplication is a homeomorphism, $[g]_\phi$ must be closed in G_ϕ and hence in G . \square

This gives rise to the following crucial statement.

Lemma 5.23. *Let G be a group containing some normal conjugacy separable subgroup N of finite index. Then any finite subgroup H_1 of G satisfying $H_1 \cap N = \{1_G\}$ is con-separated in G .*

Proof: By Lemma 5.6 we can assume that $G = H_1 \cdot N \cong H_1 \times N$. So let H_2 be a finitely generated subgroup of G . Choose some finite set $B \subseteq H_2$ such that $H_2 = \langle B \rangle$. Thus for any $g \in G$ it follows $H_2^g \leq H_1$ if and only if $B^g \subseteq H_1$. So assume that $B^g \not\subseteq H_1$ for any $g \in G$. Since $G = H_1 \cdot N \cong H_1 \times N$ it follows that for any $b \in B$ there exists unique $a_b \in H_1$ and $n_b \in N$ such that $b = a_b \cdot n_b$. Moreover the set $\{x_b | b \in H_2\}$ is finite as B is a finite generating set. Note that since H_1 is finite any element $a \in H_1$ is of finite order. Thus any $a \in H_1$ induces a virtually inner automorphism $\phi_a : N \rightarrow N, n \mapsto n^a$. As by Lemma 5.22 the twisted conjugacy classes are closed in N it follows that for any $b \in B$ and any $a \in H_1$ there exists a finite index subgroup N_b^a in N such that $[n_b]_{\phi_a} \cap N_b^a = \emptyset$. Thus $\hat{N} := \bigcap_{b \in B} N_b^a$ is a finite index subgroup of N . W.l.o.g. we can assume that \hat{N} is characteristic in N implying that $\hat{N} \trianglelefteq G$. Hence $D := H_1 \cdot \hat{N}$ is a finite index subgroup of G containing H_1 . Assume that $B^{g^{-1}} \subseteq D$ for some $g \in G$. Clearly there exists $a \in H_1$ and $n \in N$ such that $g = an$ and it follows for any $b \in B$:

$$b^{g^{-1}} = (an)a_b n_b (n^{-1}a^{-1}) = aa_b (n^{a_b} n_b n^{-1}) a^{-1} \in D.$$

Since $a, a_b \in D$ we deduce that $(a_b^{-1} b^{g^{-1}})^a = n^{a_b} n_b n^{-1} \in D$ and therefore

$$n^{a_b} n_b n^{-1} \in D \cap N = (H_1 \cdot \hat{N}) \cap N = (H_1 \cap N) \cdot \hat{N} = \hat{N}.$$

If now $n^{a_b} n_b n^{-1} \neq 1_G$ it follows $n^{a_b} n_b n^{-1} \in [n_b]_{\phi_{a_b}} \cap \hat{N}$ contradicting $[n_b]_{\phi_{a_b}} \cap \hat{N} = \emptyset$. Thus $b^{g^{-1}} = a_b^{-1}$ for any $b \in B$ implying that $B^g \subseteq A$. A contradiction. \square

Combining Lemma 5.23 with Corollary 5.15 and Lemma 5.6, we obtain the following important statement:

Corollary 5.24. *Let G be a group which does not admit expanding inner automorphisms. Moreover assume that G contains a conjugacy separable group of finite index and that any f.g. infinite subgroup H is con-separated from any f.g. infinite subgroup H_2 of G , which is not already conjugate into H_1 in G . Then G is subgroup conjugacy separable.*

Proof: So let G be a group which does not admit expanding inner automorphisms. Moreover assume that G contains a conjugacy separable group of finite index and assume that any f.g. infinite subgroup H is con-separated in G . Let H_1 and H_2 be two f.g. non-conjugate subgroups of G . We have to show that there exists a finite quotient of G such that the image of H_1 is not conjugate to H_2 . By Lemma 5.15 w.l.o.g. we can assume that H_2 is not conjugate into H_1 . If H_1 is finite it follows from Lemma 5.23 that H_1 is con-separated from H_2 within G . So assume that H_1 is infinite. If H_2 is infinite then H_1 is con-separated from H_2 by assumption. If H_2 is finite then H_1 cannot be conjugate into H_2 , since H_1 is assumed to be infinite. Thus H_2 is con-separated from H_1 by Lemma 5.23. Anyway by Lemma 5.4 there exists a finite quotient such that the image of H_2 is not conjugate into H_1 or the image of H_1 is not conjugate into the image of H_2 implying that the image H_1 is not conjugate to image H_2 . Thus G is SCS. \square

So in order to prove that a group G , which contains some cs-group of finite index and does not admit expanding inner automorphism, is SCS, we only have to show that any f.g. infinite subgroup $H \leq G$ is con-separated from any f.g. infinite subgroup H_2 , which is not already conjugate into H_1 in G .

5.4 A proof that virtually free groups are SCS

In this chapter we show that any f.g. virtually free group is subgroup conjugacy separable. While I was working on this thesis in [33] the authors proved independently the same result using techniques of profinite topology exclusively. However we will give a proof using covering theory of graphs of groups. As well as the authors of [33] we will make use of the following statement which is proven in [10] combined with [40].

Theorem 5.25. *Any f.g. virtually free group is conjugacy separable.* \square

From now on let \mathbb{B} be a minimal finite graph of finite groups with no loops.

Lemma 5.26. *Let A be finite subgroup of $G = \pi_1(\mathbb{B}, u_0)$ and let $A^G = \{a^g | a \in A \wedge g \in G\}$. Define $X := \{[p] \in G | \exists q \in [p] : |q| \leq M\}$ for some $M \in \mathbb{N}$. Then there exists a finite index subgroup D_X of G containing A , s.t. the following two properties are satisfied:*

1. *Any $x \in X \setminus A^G$ is not conjugate into D_X .*
2. *$x \notin D_X$ for any $x \in X \setminus A$.*

Proof: Since \mathbb{B} is a finite graph of finite groups, we deduce that X is a finite set. Since G is a f.g. virtually free group it follows by Theorem 5.25 that G is CS and therefore FCS. By applying Lemma 5.18 there exists a subgroup of finite index D_X^1 containing A satisfying the first property and since G is subgroup separable by Theorem 3.93 it follows that there exists a finite index subgroup D_X^2 containing A satisfying the second condition. Now the claim follows for $D_X := D_X^1 \cap D_X^2$. \square

Definition 5.27. *Let \mathbb{C} be a graph of groups with underlying graph C . We call a non-trivial path $\gamma = e_1 \dots, e_k$, $k \in \mathbb{N}$, in C essential if $\alpha_{e_1}(C_{e_1}) \not\leq C_{\alpha(e_1)}$ and $\omega_{e_k}(C_{e_k}) \not\leq C_{\omega(e_k)}$. Moreover we call the vertices $\alpha(e_1)$ and $\omega(e_k)$ the associated essential vertices.*

Corollary 5.28. *Let $\mathfrak{f} : \mathbb{A} \rightarrow \mathbb{B}$ be a folded morphism of finite graphs of finite groups, s.t. $VA = \{v_0\}$, $EA = \emptyset$ and $A_{v_0} \leq B_{u_0}$ for some $u_0 \in VB$ and $f_{v_0} = \text{id}$. Moreover let M be natural number s.t. $M \geq 2 \cdot d + 2$ for $d := \max_{u \in VB} d(u_0, u)$. Then there exists a finite-sheeted covering $\mathfrak{g} : \mathbb{C} \rightarrow \mathbb{B}$ representing some subgroup $D \leq G$ satisfying the following properties:*

- (1) *$A_{v_0} = C_{w_0}$, which means that \mathbb{A} is geometric in \mathbb{C} .*
- (2) *For any elliptic element $x \in D$ we have that $x^g \leq A_{v_0}$ for some $g \in G$.*
- (3) *Let $\gamma = e_1, \dots, e_k$, $k \in \mathbb{N}$, be an essential path in C . Then $k > \frac{M-2d}{2}$.*
- (4) *Let $\gamma = e_1, \dots, e_k$, $k \in \mathbb{N}$, form a non-trivial circle in C , i.e. γ is reduced, $k > 1$ and $\alpha(e_1) = \omega(e_k)$. Then $k > M - 2d$.*
- (5) *Let $\gamma = e_1, \dots, e_k$, $k \in \mathbb{N}$, be a non-trivial reduced path in C such that $\alpha(e_1) = \omega(e_k) = w_0$. Then $k > M - 2d$.*
- (6) *Let $\gamma = e_1, \dots, e_k$, $k \in \mathbb{N}$, be a non-trivial reduced path in C such that $\alpha(e_1) = w_0$ and $\omega_{e_k}(C_{e_k}) \not\leq C_{\omega(e_k)}$. Then $k > \frac{M-2d}{2}$.*

Proof: So let M be a natural number s.t. $M \geq 2 \cdot d + 2$ for $d := \max_{u \in VB} d(u_0, u)$. Let $X := \{[p] \in G \mid \exists q \in [p] : |q| \leq M\}$. Then Lemma 5.26 implies that there exists a finite index subgroup D_X of G containing $[A_{v_0}]$ satisfying

- (a) Any $x \in X \setminus [A_{v_0}]^G$ is not conjugate into D_X and
- (b) $x \notin D_X$ for any $x \in X \setminus [A_{v_0}]$.

Let $\mathfrak{g} : \mathbb{C} \rightarrow \mathbb{B}$ be a finite-sheeted cover representing D_X . W.l.o.g. we may assume that for the base vertex $w_0 \in VC$ holds $g_{w_0} = \text{id}$ implying that $A_{v_0} \leq C_{w_0}$ as $[A_{v_0}] \leq D_X$. Clearly $[b] \in X \setminus [A_{v_0}]$ for any $b \in B_{u_0} \setminus A_{v_0}$. Thus (b) implies $A_{v_0} = C_{w_0}$ proving (1).

For (2) let $x \in D_X \leq G = \pi_1(\mathbb{B}, u_0)$ be an elliptic element. For any vertex $u \in VB$ let q_u be a \mathbb{B} -path of length $d(u_0, u)$ connecting u_0 with u . Note that any elliptic element of G is conjugate to some element of the form $[q_u \cdot b \cdot q_u^{-1}]$ for some $u \in VB$ and some $b \in B_u$. Thus there exists $g \in G$ such that $x^g = [q_u \cdot b \cdot q_u^{-1}]$ for some $u \in VB$ and some $b \in B_u$ implying that $x^g \in X$ since $|q_u \cdot b \cdot q_u^{-1}| = 2 \cdot d(u_0, u) < M$. Therefore we conclude by (a) that $x^g \in [A_{v_0}]^G$ proving (2).

For (3) and (4) assume that there exists a path $\gamma = e_1, \dots, e_k$, $k \in \mathbb{N}$, such that either γ is essential and $k \leq \frac{M-2d}{2}$ or γ forms a non-trivial circle in C and $k \leq M - 2d$. Since \mathbb{C} is a covering we deduce that in both cases we find a hyperbolic element $x \in G$ such that $x = [\mu_{\mathfrak{g}}(p_{w,w'} \cdot p \cdot p_{w,w'}^{-1})]$ for some \mathbb{C} paths $p_{w,w'}$ and p satisfying the following conditions:

- $\alpha(p) = \omega(p) = w' = \alpha(e_1)$ and $|p| \leq M - 2d$,
- $\alpha(p_{w,w'}) = w$ and $\omega(p_{w,w'}) = w'$ for some $w \in g^{-1}(u_0) \subseteq VC$ with $|p_{w,w'}| \leq d$.

Thus x is conjugate into D_X and $|p_{w,w'} \cdot p \cdot p_{w,w'}^{-1}| \leq M$. Hence it follows by (a) that x is conjugate into $[A_{v_0}]$, contradicting that x acts hyperbolic. This proves (3) and (4). Note that (4) implies (5). Moreover (6) is an immediate consequence of the fact that $x \notin D_X$ for any $x \in X \setminus [A_{v_0}]$, completing the proof. \square

This corollary will be the base in the proof by induction of the following statement:

Proposition 5.29. *Let $U \leq \pi(\mathbb{B}, u_0)$ and M be natural number s.t. $M \geq 2 \cdot d + 2$ for $d := \max_{u \in VB} d(u_0, u)$. Let $\mathfrak{f} : \mathbb{A} \rightarrow \mathbb{B}$ representing $U = \pi_1(\mathbb{A}, v_0)$ for some $v \in VA$ such that $\text{core}(\mathbb{A}, v_0) = \mathbb{A}$. Then there exists a finite covering $\mathfrak{g} : \mathbb{C} \rightarrow \mathbb{B}$ representing some subgroup $D \leq G$ satisfying the following properties:*

- (1) \mathbb{A} is geometric in \mathbb{C} .
- (2) For any elliptic element $x \in D$ we have that $x^g \leq U$ for some $g \in G$.
- (3) Let $\gamma = e_1, \dots, e_k$, $k \in \mathbb{N}$, be an essential path in C such that there exists $w \in \{\alpha(e_1), \omega(e_k)\}$ satisfying $w \notin VA$. Then $k > \frac{M-2d}{2}$.
- (4) Let a reduced path $\gamma = e_1, \dots, e_k$, $k \in \mathbb{N}$, with $e_r \notin EA$ for some $r \in \{1, \dots, k\}$ form a non-trivial circle in C , i.e. γ is reduced, $k > 1$ and $\alpha(e_1) = \omega(e_k)$. Then $k > M - 2d$.

(5) Let $\gamma = e_1, \dots, e_k$, $k \in \mathbb{N}$, be a reduced path in C such that $e_r \in EC \setminus EA$ for some $r \in \{1, \dots, k\}$ and $\alpha(e_1), \omega(e_k) \in VA$. Then $k > M - 2d$.

(6) Let $\gamma = e_1, \dots, e_k$, $k \in \mathbb{N}$, be a non-trivial reduced path in C such that $e_i \in EC \setminus EA$ for some $i \in \{1, \dots, k\}$ and $\alpha(e_1) \in VA \subseteq VC$ and $\omega_{e_k}(C_{e_k}) \preceq C_{\omega(e_k)}$. Then $k > \frac{M-2d}{2}$.

Proof: We will prove the assumption by induction over the finite number of vertices in A . As mentioned before, Corollary 5.28 proves the case $|VA| = 1$. So let $|VA| = n$. Now we will proceed as in the proof of Theorem 3.78. So create two subgraph of groups \mathbb{A}^1 and \mathbb{A}^2 as in the proof of Theorem 3.78 by removing some suitable edges of EA . Then $VA^i < n$ for $i \in \{1, 2\}$. By induction hypothesis there exists a covering \mathbb{C}^i for \mathbb{A}^i satisfying (1)-(6). Clearly we can proceed as in the proof of Theorem 3.78 to create a covering \mathbb{C} such that \mathbb{A} is geometric in \mathbb{C} . So it's left to prove that this covering of graphs of groups is the desired one. Since the properties (1) and (2) are obvious we are going to show the properties (3)-(6).

Before we start with the proof, we observe the following:

Observation ():*

Let $i \in \{1, 2\}$. By induction hypothesis we can assume that property (5) holds for \mathbb{C}^i . Thus it follows that for any two edges $e_1, e_2 \in EC^i$ satisfying $\alpha(e_1), \alpha(e_2) \in VA^i$ that the distance of two vertices x and y with $x \in \{\alpha(e_1), \omega(e_1)\}$ and $y \in \{\alpha(e_2), \omega(e_2)\}$ is greater than $M - 2d - 2$. Note that there are two types of identified edges in the constructed covering \mathbb{C} . The set of edges E which lie in the copy of \mathbb{A} in \mathbb{C} and the set F of identified edges which do not lie in the copy of \mathbb{A} in \mathbb{C} . Let $f_1, f_2 \in E \cup F$ with $f_1 \neq f_2$. Then it is an immediate consequence of the previous argument that for any reduced path $\gamma = e_1, \dots, e_k$, $k \in \mathbb{N}$, with $\alpha(e_1) = \alpha(f_1)$, $\omega(e_k) = \alpha(f_2)$ and $e_r \notin EA^i \subseteq EC^i$ for any $r \in \{1, \dots, k\}$ that $k > M - 2d - 2$ since (5) holds for \mathbb{C}^i .

*Observation (**):*

Let $f \in F$. Then a similar argument as above implies that the distance of any two vertices x and v with $x \in \{\alpha(f), \omega(f)\}$ and $v \in VA$ is greater than $M - 2d - 1$.

Keeping this in mind, we start with proving (5). So let $\gamma = e_1, \dots, e_k$, $k \in \mathbb{N}$, be a reduced path in C such that $e_i \in EC \setminus EA$ and $\alpha(e_1), \omega(e_k) \in VA$. If γ can be regarded as a path in \mathbb{C}^i for some $i \in \{1, 2\}$ before constructing \mathbb{C} out of \mathbb{C}^1 and \mathbb{C}^2 , the claim follows since we can assume that (5) holds for \mathbb{C}^i by inductive hypothesis. Otherwise γ must cross some $f \in F$ and the claim is easily verified by (**).

If $\omega(e_k) \notin VA$ an analogous argumentation as above shows (6) by applying (*) instead of (**). Moreover if $\omega(e_k) \in VA$ then it follows that (6) is an immediate consequence of (5). So we are left to show (3) and (4). For (3) let $\gamma = e_1, \dots, e_k$, $k \in \mathbb{N}$, be an essential path in C such that there exists $w \in \{\alpha(e_1), \omega(e_k)\}$ satisfying $w \notin VA$.

Case 1: Assume that $\alpha(e_1), \omega(e_k) \in VC^i$ for some $i \in \{1, 2\}$ before constructing \mathbb{C} out of \mathbb{C}^1 and \mathbb{C}^2 . By inductive hypothesis we can assume that γ passes some $f \in F$ or some $e \in E$. Thus there exists $r, s \in \{1, \dots, k\}$ with $r \neq s$ such that $e_r, e_s \in F \cup E$ since $\alpha(e_1), \omega(e_k) \in VC^i$. Hence the claim follows by (*).

Case 2: W.l.o.g. assume that $\alpha(e_1) \in VC^1$ and $\omega(e_k) \in VC^2$. Thus there exists some $r \in \{1, \dots, k\}$ and subpaths $\gamma_1 = e_1, \dots, e_{r-1}$ and $\gamma_2 = e_{r+1}, \dots, e_k$ of γ such that $e_r \in F$ and γ_i can be regarded as a path in C^i for $i \in \{1, 2\}$ before constructing \mathbb{C} out of \mathbb{C}^1 and \mathbb{C}^2 . Thus $|\gamma_i| > \frac{M-2d}{2} - 1$ since (6) holds for \mathbb{C}^i , $i \in \{1, 2\}$, by induction. Clearly this implies $k > \frac{M-2d}{2}$.

So it's left to prove (4). So let a reduced path $\gamma = e_1, \dots, e_k$, $k \in \mathbb{N}$, with $e_r \notin EA$ for some $r \in \{1, \dots, k\}$ form a non-trivial circle in C , i.e. γ is reduced, $k > 1$ and $\alpha(e_1) = \omega(e_k)$. If $e_s \notin F \cup E$ for any $s \in \{1, \dots, k\}$ the claim follows by inductive hypothesis. So assume the contrary. Thus there exists $r, s \in \{1, \dots, k\}$ such that $r \neq s$ and $e_r, e_s \in F \cup E$ since γ is closed and we conclude by (*) that $k > M - 2d$ proving the statement. \square

Corollary 5.30. *Let \mathbb{B} be a finite graph of finite groups and let $G = \pi_1(\mathbb{B}, u_0)$ for some $u_0 \in VB$. Then any f.g. infinite subgroup H_1 is con-separated from any f.g. infinite subgroup H_2 of G , which is not already conjugate into H_1 in G .*

Proof: So let \mathbb{B} be a finite graph of finite groups, $G = \pi_1(\mathbb{B}, u_0)$ for some $u_0 \in VB$ and let $H_1, H_2 \leq G$ be two f.g. infinite subgroups of G such that H_2 is not conjugate into H_1 in G . Choose some representing folded morphism $\mathfrak{f}_i : \mathbb{A}_i \rightarrow \mathbb{B}$ for H_i , $i \in \{1, 2\}$, such that $\text{core}(\mathbb{A}_1, v_0^1) = \mathbb{A}_1$ and $\text{core}(\mathbb{A}_2, v_0^2) = \mathbb{A}_2$ for some suitable base vertices $v_0^i \in A_i$, $i \in \{1, 2\}$. Furthermore let $d := \max_{u \in VB} d(u_0, u)$ and $d_2 := \max_{v_1, v_2 \in VA_2} d(v_1, v_2)$ and let M be natural number with $M \geq \max\{4d + 2, 4d_2 + 2\}$. Create the covering $\mathfrak{g} : \mathbb{C} \rightarrow \mathbb{B}$ as in Proposition 5.29 for \mathbb{A}_1 and M . Then the the morphism \mathfrak{g} represents a finite index subgroup D_M of G containing H_1 . Assume that H_2 is conjugate into D_M . Then there exists a folded morphism from $\mathfrak{h} : \mathbb{A}_2 \rightarrow \mathbb{C}$ representing some conjugate of H_2 in D_M , i.e. $\varphi_{\mathfrak{g}}|_{\varphi_{\mathfrak{h}}(\pi_1(\mathbb{A}_2, v_0^2))} \circ \varphi_{\mathfrak{h}}(\pi_1(\mathbb{A}_2, v_0^2)) = H_2^g$ for some $g \in G$. Thus we deduce by condition (3) and (4) that by the choice of M the represented subgroup of \mathfrak{h} must be either elliptic or it is already a subgroup of H_1 . Since H_2 is not conjugate into H_1 it follows that H_2 is elliptic and therefore finite which provides the conclusive contradiction. \square

We conclude by Lemma 5.24:

Theorem 5.31. *Let G be a f.g. virtually free group. Then G is subgroup conjugacy separable.*

Proof: By Theorem 3.90 one can assume that $G = \pi_1(\mathbb{B}, u_0)$ for some finite graph of finite groups \mathbb{B} and some $u_0 \in VB$. By Theorem 5.25 G is conjugacy separable and by Corollary 5.12 G admits no expanding inner automorphism. Thus Corollary 5.30 implies that the claim is a direct consequence of Corollary 5.24. \square

6 Fuchsian groups are SCS

Planar groups act properly discontinuously by isometries on \mathbb{H}^2 , \mathbb{R}^2 or \mathbb{S}^2 and are classified by their orbifold, i.e. by the quotient space of the respective plane modulo the group action where one needs to record rotation orders of images of fixed points and reflections. The groups can then be recovered as the fundamental group of the orbifold. Details can be found in the beautiful article of P. Scott [37]. In this work we restrict us to that kind of group actions, where the corresponding orbifold is orientable. In particular in the case, where the acting group G is a Fuchsian group:

Definition 6.1. *We call a group G a Fuchsian group if G is a discrete subgroup of $\text{Isom}^+(X)$ for $X \in \{\mathbb{H}^2, \mathbb{R}^2, \mathbb{S}^2\}$.*

As mentioned before, the associated quotient space $\mathcal{O} = X/G$ is an orientable 2-dimensional orbifold such that $\pi_1(\mathcal{O}) \cong G$. If G is f.g., we will see that \mathcal{O} can be assumed to be compact and such a compact orientable 2-orbifold can be easily described in the form $\mathcal{O} = (\Sigma_{g(\Sigma)}^n; p_1, \dots, p_m)$ where Σ is a surface with n boundary components of genus $g(\Sigma)$ and $p_i \in \mathbb{N}_{\geq 2}$ are the rotation orders of the cone points.

The aim of the following four sections of this chapter is to give a proof for the following statement.

Theorem 6.2. *Finitely generated Fuchsian groups are SCS.*

The ideas are based on the ideas of [3], where the authors showed that the fundamental group of a compact closed orientable surface is SCS.

Afterwards we will use Theorem 6.2 to prove in chapter 9 that fundamental groups of totally orientable compact Seifert 3-manifolds are SCS as well. For this we will use the following result. A proof can be found in [37]:

Theorem 6.3. *Let M be a Seifert fibered space. Then there exists a short exact sequence*

$$1 \rightarrow C \rightarrow \pi_1(M) \rightarrow H \rightarrow 1,$$

such that C is a cyclic group and H is the fundamental group of a 2-dimensional orbifold \mathcal{O} .

Now we define a totally orientable Seifert 3-manifold as follows:

Definition 6.4. *Let M be a Seifert fibered space. M is called totally orientable if there exists a short exact sequence*

$$1 \rightarrow C \rightarrow \pi_1(M) \rightarrow H \rightarrow 1,$$

*such that $H = \pi_1(\mathcal{O})$ for some **orientable** 2-orbifold \mathcal{O} .*

So we will show:

Theorem 6.5. *Let M be a totally orientable Seifert fibered space such that there exists a short exact sequence*

$$1 \rightarrow C \rightarrow \pi_1(M) \rightarrow H \rightarrow 1$$

*with $H = \pi_1(\mathcal{O})$ finitely generated for some **orientable** 2-orbifold \mathcal{O} . Then $\pi_1(M)$ is SCS.*

The cases where $\pi_1(\mathcal{O})$ acts on \mathbb{R}^2 or \mathbb{S}^2 will be dealt separately in the next section (6.1), while the interesting case, i.e. where $\pi_1(\mathcal{O})$ acts on \mathbb{H}^2 , will be discussed in the sections 6.2-6.4.

6.1 Virtually Polycyclic Groups

In this chapter we will show that any discrete subgroup of $\text{Isom}^+(X)$ for $X \in \{\mathbb{R}^2, \mathbb{S}^2\}$ and the fundamental group of the pillow orbifold are SCS. In addition we will show that the corresponding fundamental group of a Seifert fibered space M with the property that in the corresponding short exact sequence of Definition 6.4, we have $H \in \text{Isom}^+(X)$ for $X \in \{\mathbb{R}^2, \mathbb{S}^2\}$ or $H = \pi_1(\mathcal{O})$ for the pillow orbifold \mathcal{O} is SCS. For this we will exploit that any virtually polycyclic group is SCS.

Definition 6.6. *A group G is called polycyclic if there exists a subnormal series*

$$G = G_0 \geq G_1 \geq \dots \geq G_{n-1} \geq G_n = \{1_G\}$$

*with cyclic factors. Such a series is called **pc series** of G .*

Definition 6.7. *A group G is called virtually polycyclic if G has a polycyclic subgroup of finite index.*

In [38] on page 69 Theorem 7 it is proven:

Theorem 6.8. *Virtually polycyclic groups are SCS.* □

We will deal now with the case, where H is a group acting on \mathbb{R}^2 or \mathbb{S}^2 :

Theorem 6.9. *Let H be a discrete subgroup of $\text{Isom}^+(\mathbb{R}^2)$. Then there exists a short exact sequence*

$$1 \rightarrow T \rightarrow H \rightarrow E \rightarrow 1,$$

such that E is a finite group and $T \in \{\{1_T\}, \mathbb{Z}, \mathbb{Z} \times \mathbb{Z}\}$. □

Hence in this case H is virtually abelian and therefore virtually polycyclic. Moreover the same holds for an associated Seifert fibered space:

Corollary 6.10. *Let $G = \pi_1(M)$ for some Seifert fibered space M , where in the corresponding short exact sequence*

$$1 \rightarrow C \rightarrow \pi_1(M) \xrightarrow{\varphi} H \rightarrow 1,$$

we have $H \in \text{Isom}^+(\mathbb{R}^2)$.

Proof: Clearly in this case, we have that $C \cong \mathbb{Z}$. By Theorem 6.3 there exists a short exact sequence

$$1 \rightarrow T \rightarrow H \rightarrow E \rightarrow 1,$$

such that E is a finite group and $T \in \{\{1_T\}, \mathbb{Z}, \mathbb{Z} \times \mathbb{Z}\}$. Hence there exists a normal finite index subgroup $N \cong T$ in H . Let $G_0 := \varphi^{-1}(N)$. Then G_0 is a normal subgroup of finite index in G . If $G_0/C \cong T \in \{\{1_T\}, \mathbb{Z}\}$ the statement is trivial. So let $T \cong \mathbb{Z} \times \mathbb{Z}$. Then it is easy to see that $G_0 \cong (\mathbb{Z} \times \mathbb{Z}) \rtimes \mathbb{Z}$ and therefore G_0 is polycyclic. Hence the statement follows by Theorem 6.8. □

As explained in [37], we have that:

Lemma 6.11. *Let H be a discrete subgroup of $\text{Isom}^+(\mathbb{S}^2)$. Then H is a finite.* □

So by 6.8 we conclude:

Corollary 6.12. *Let H be a discrete subgroup of $\text{Isom}^+(X)$ with $X \in \{\mathbb{S}^2, \mathbb{R}^2\}$. Then H is SCS. \square*

Corollary 6.13. *Let $G = \pi_1(M)$ for some Seifert fibered space M , where in the corresponding short exact sequence*

$$1 \rightarrow C \rightarrow \pi_1(M) \xrightarrow{\varphi} H \rightarrow 1,$$

we have $H \in \text{Isom}^+(X)$ with $X \in \{\mathbb{S}^2, \mathbb{R}^2\}$. Then G is SCS. \square

In the paper [37] it is shown that:

Theorem 6.14. *If G is a subgroup of $\text{Isom}^+(\mathbb{H})$, then G contains a surface group of finite index. \square*

Moreover it is known that any surface group is CS (see [25]):

Theorem 6.15. *Let G be a group having a surface group of finite index. Then G is conjugacy separable. \square*

Combining this fact with Corollary 5.11 and Corollary 5.24 we obtain:

Corollary 6.16. *Let G be a subgroup of $\text{Isom}^+(\mathbb{H})$ and assume that any f.g. infinite subgroup H_1 is con-separated from any f.g. infinite subgroup H_2 not already conjugate into H_1 . Then G is SCS. \square*

6.2 Subgroups of Fuchsian groups are almost geometric

In the light of the last corollaries we only need to show that any f.g. infinite subgroup H_1 is con-separated from any f.g. infinite subgroup H_2 not already conjugate into H_1 , since this would imply Theorem 6.2. To provide another reduction of Theorem 6.2 with the help of Lemma 5.6, we will now show that 2-dimensional orbifolds are "almost geometric" in the sense of Scott's paper [36]. In this paper he showed that surface groups are "almost geometric", which means roughly speaking that any f.g. subgroup of a surface group, is realizable as the fundamental group of compact subsurface in a finite-sheeted covering of the whole surface. This fact he uses to show the following:

Theorem 6.17. *Let G the fundamental group of a compact surface. Then G is subgroup separable.* \square

In addition he proved in [36] that the Subgroup Separability is closed under finite extension of groups. Combining this with Theorem 6.14 leads to the following crucial consequence:

Corollary 6.18. *Fuchsian groups are subgroup separable.* \square

The upcoming statements are translations of statements 1.4-1.6 of [36] to the orbifold case. Scott used them to prove the subgroup separability for surface groups. Since by 6.18 Fuchsian groups are subgroup separable, we will go the other way around and use this fact to show, that subgroups of Fuchsian groups are "almost geometric" as well as subgroups of surface groups.

In order to make the connection between the subgroup separability and topology, we make use of the following result (see [36], Lemma 1.2):

Lemma 6.19. *Let X be a Hausdorff topological space with regular covering \tilde{X} and Deck-transformation group G . Then the set of elements $\{g \in G \mid gC \cap C \neq \emptyset\}$ is finite for any compact subset C of \tilde{X} .* \square

Definition 6.20. *Let G be a group acting on a space X . We define a fundamental region for G to be a closed subset P of X such that the following holds:*

1. $\bigcup_{g \in G} gP = X$
2. $P_{int} \cap gP_{int} = \emptyset$ for all non-trivial elements $g \in G$, where P_{in} denotes the interior of P .

Lemma 6.21. *Let \mathcal{O} be a compact 2-dimensional orbifold. Let $\tilde{\mathcal{O}}$ be a regular orbifold covering of \mathcal{O} with Decktransformation group G . Then G is subgroup separable if and only if given a f.g. subgroup $U \leq G$ and a compact subset C of $\tilde{\mathcal{O}}/U$, there is a finite covering $\hat{\mathcal{O}}$ of \mathcal{O} such that the projection $\tilde{\mathcal{O}}/U \rightarrow \mathcal{O}$ factors through $\hat{\mathcal{O}}$ and C projects homeomorphically into $\hat{\mathcal{O}}$.*

Proof: " \Leftarrow ": Suppose that the geometric condition holds and that U is a f.g. subgroup of G and g is an element of $G \setminus U$. Pick $x \in \tilde{\mathcal{O}}$ such that $gx \neq x$ and let C in $\tilde{\mathcal{O}}/U$ be the image of $\{x, gx\}$. The geometric condition provides us with a finite covering $\hat{\mathcal{O}}$ of \mathcal{O} such that the projection $\tilde{\mathcal{O}}/U \rightarrow \mathcal{O}$ factors through $\hat{\mathcal{O}}$ and C projects homeomorphically into $\hat{\mathcal{O}}$.

Clearly $\widehat{\mathcal{O}} = \widetilde{\mathcal{O}}/\widehat{G}$ for some finite index subgroup \widehat{G} of G containing U , such that g does not lie in \widehat{G} as $\{x, gx\}$ projects homeomorphically into $\widehat{\mathcal{O}}$. Hence G is subgroup separable.

" \Rightarrow ": Now suppose that G is subgroup separable and that we are given a f.g. subgroup U of G and a compact subset C of $\widetilde{\mathcal{O}}/U$. Let p denote the projection map $\widetilde{\mathcal{O}} \rightarrow \widetilde{\mathcal{O}}/U$, and let Y denote $p^{-1}(C)$ in \mathcal{O} . Since \mathcal{O} is compact, there exist a fundamental domain X in $\widetilde{\mathcal{O}}$ for \mathcal{O} , such that X is compact. Hence the restriction $p|_X : X \rightarrow Y$ is a continuous map and since Y is Hausdorff any preimage of a compact subset of Y is compact. Therefore there exists a compact subset $D \subset X \subset \widetilde{\mathcal{O}}$, such that $p(D) = C$. Recall that $\{g \in G : gD \cap D \neq \emptyset\}$ is finite, by Lemma 6.19. As G is subgroup separable we can find a subgroup \widehat{G} of finite index in G such that \widehat{G} contains U and, in addition, if g is an element of \widehat{G} such that gD meets D then g lies in U . Then $\widehat{\mathcal{O}} = \widetilde{\mathcal{O}}/\widehat{G}$ is the required finite covering of \mathcal{O} . \square

Let \mathcal{O} be a compact orientable 2-orbifold decomposed into sub-2-orbifolds $\mathcal{C}_1, \dots, \mathcal{C}_n$, i.e., \mathcal{O} is obtained from the sub-2-orbifolds by gluing them along boundary circles. In the 2-orbifold, these circles appear as cutting circles along which \mathcal{O} is decomposed. We say that \mathcal{C}_i , $i \in \{1, \dots, n\}$, is an incompressible sub-2-orbifold if the embedding $\mathcal{C}_i \hookrightarrow \mathcal{O}$ induces the embedding of fundamental groups: $\pi_1(\mathcal{C}_i) \hookrightarrow \pi_1(\mathcal{O})$. Geometrically this means that the complement of \mathcal{C}_i in \mathcal{O} does not have disc components or disc components containing exactly one cone point.)

Now we want to translate Lemma 1.5. of [36], into the 2-orbifold case. Since our proof of this translation makes use of the original statement, we shall repeat the original statement first:

Lemma 6.22. *Let S be a surface such that $\pi_1(S)$ is finitely generated and let C be a compact subset of S . Then there is a compact, connected, incompressible subsurface \widehat{S} of S which contains C such that the natural map $\pi_1(\widehat{S}) \rightarrow \pi_1(S)$ is an isomorphism. \square*

In the case of a 2-dimensional orbifold, we deduce the following:

Corollary 6.23. *Let \mathcal{O} be a 2-dimensional orbifold such that $\pi_1(\mathcal{O})$ is finitely generated and let C be a compact subset of \mathcal{O} . Then there is a compact, connected, incompressible sub-2-orbifold $\widehat{\mathcal{O}}$ of \mathcal{O} which contains C such that the natural map $\pi_1(\widehat{\mathcal{O}}) \rightarrow \pi_1(\mathcal{O})$ is an isomorphism.*

Proof: Let \mathcal{O} be a 2-dimensional orbifold with underlying surface Σ such that $\pi_1(\mathcal{O})$ is finitely generated and let C be a compact subset of \mathcal{O} . Since $\pi_1(\mathcal{O})$ is finitely generated \mathcal{O} has only finitely many cone points, say P_1, \dots, P_m . Let now P denote the union of these cone points. Clearly one can extend C such that any cone point lies in C . Let S denote \mathcal{O} with the interiors of small cones centred on the cone points removed. Thus $\partial(S) = \partial\Sigma \cup R_1 \cup \dots \cup R_m$, where R_i is the boundary of the removed cone point neighborhood corresponding to the cone point P_i for any $i \in \{1, \dots, m\}$. Clearly $\pi_1(S)$ is finitely generated, since $\pi_1(\Sigma)$ is. Now Lemma 6.22 provides us a compact incompressible subsurface \widehat{S} of S such that the natural map $\pi_1(\widehat{S}) \rightarrow \pi_1(S)$ is an isomorphism. By undoing the removing of the cone points we obtain a compact 2-dimensional orbifold $\widehat{\mathcal{O}}$ and it is easily verified that the natural map $\pi_1(\widehat{\mathcal{O}}) \rightarrow \pi_1(\mathcal{O})$ is an isomorphism (for details see [37]). \square

Putting Lemma 6.21 and 6.22 together we obtain the following immediate consequence:

Corollary 6.24. *Let \mathcal{O} be a 2-dimensional orbifold. Then $G := \pi_1(\mathcal{O})$ is subgroup separable if and only if given a f.g. subgroup U of G and $g \in G \setminus U$, there is a finite covering $\widehat{\mathcal{O}}$ of \mathcal{O} such that $\pi_1(\widehat{\mathcal{O}})$ contains U but not g and U is geometric in $\widehat{\mathcal{O}}$.*

Proof: The proof is a direct consequence of 6.21 if $\widehat{\mathcal{O}}$ is supposed to be the universal covering of \mathcal{O} . In the second direction we only have to assume that C is a compact incompressible sub-2-orbifold of \mathcal{O} which fulfills the property that the natural map $\pi_1(C) \rightarrow \pi_1(\mathcal{O}_U)$ is an isomorphism. Note that such C exists by Corollary 6.23. \square

By Theorem 6.18 combined with Lemma 6.24 we obtain:

Proposition 6.25. *Let $G = \pi_1(\mathcal{O})$ be a Fuchsian group and $H_1 \leq G$ be a f.g. subgroup. Then there exists a finite-sheeted covering $\widehat{\mathcal{O}} \rightarrow \mathcal{O}$, such that H_1 is geometric in $\widehat{\mathcal{O}}$, that is H_1 is the fundamental group of a compact 2-dimensional sub-orbifold of $\widehat{\mathcal{O}}$. \square*

Recall the following:

Definition 6.26. *A subgroup H of a group G is malnormal if $H^g \cap H = \{1_G\}$ for all $g \in G$ with $g \notin H$.*

Suppose we are given a orientable 2-dimensional orbifold $\widehat{\mathcal{O}}$ with finitely generated fundamental group $G = \pi_1(\widehat{\mathcal{O}})$. In order to prove that G is SCS by Corollary 6.23 we can assume that $\widehat{\mathcal{O}}$ is compact. So assume that $\widehat{\mathcal{O}}$ has $n \geq 1$ boundary components and consider a surface S of genus $g(S) \geq 1$ with n boundary components. Clearly we can glue $\widehat{\mathcal{O}}$ and S along their boundary components together. The resulting space is a **closed** 2-dimensional orbifold \mathcal{O} , with the property, that $\pi_1(\widehat{\mathcal{O}})$ can be regarded as malnormal subgroup in $\pi_1(\mathcal{O})$. Thus the following statement provides a further reduction:

Lemma 6.27. *Let G be a group and let $U \leq G$ be a malnormal subgroup of G . Suppose that the f.g. subgroup $H_1 \leq U$ is con-separated from $H_2 \leq U$ within G . Then H_1 is con-separated from H_2 within U .*

Proof: Let H_1 and $H_2 \neq \{1_G\}$ be two f.g. subgroups of G such that $H_2^x \neq H_1$ for any $x \in U$. Assume that there exists $x \in G - U$ such that $H_2^x = H_1$. Then $H_2 \leq U \cap U^x$ and therefore $S_2 = \{1_G\}$ or $x \in U$. A contradiction. By assumption there exists a finite index subgroup D in G , containing H_1 such that $H_2^x \not\leq D$ for any $x \in G$. We conclude that $D_U := D \cap U$ is the desired witness of separation of H_1 and H_2 in U . \square

In order to prove that any fundamental group $G := \pi_1(\mathcal{O})$ of some orientable 2-dimensional orbifold \mathcal{O} is SCS, by Lemma 6.27 it suffices to deal with the case, where \mathcal{O} is **closed**. After applying Corollary 6.12 we can assume that $G \leq \text{Isom}^+(\mathbb{H}^2)$ and by Corollary 6.16 we only have to verify that any f.g. **infinite** subgroup H_1 of G is con-separated in G . Moreover Lemma 5.6 combined with Corollary 6.24 implies that we can assume that the subgroup H_1 is almost geometric in \mathcal{O} . Hence we conclude that for proving Theorem 6.2 it suffices to establish the following:

Theorem 6.28. *Let \mathcal{O} be a **closed** 2-dimensional hyperbolic orbifold with f.g. fundamental group $G := \pi_1(\mathcal{O})$. Then any f.g. **infinite** subgroup $H_1 \leq G$, which is realizable as a 2-dimensional-sub-orbifold, is con-separated within G from any f.g. **infinite** subgroup H_2 not conjugate into H_1 .*

As already remarked in the introduction 6.28 is as well a direct consequence of [8], Theorem 2.6.

6.3 Coverings of 2-dimensional orbifolds

Consider some 2-dimensional orbifold \mathcal{O} and some subgroup H_1 of $\pi_1(\mathcal{O})$ satisfying the requirements of Theorem 6.28. The fact that we can assume that H_1 is geometric in \mathcal{O} gives rise to a decomposition of \mathcal{O} in 2-dimensional-sub-orbifolds. For showing Theorem 6.28, we have to find a witness of separation D for any f.g. $H_2 \leq G$ which is not conjugate into H_1 . To achieve this, we will construct in the last section a finite-sheeted covering $\tilde{\mathcal{O}}$ of \mathcal{O} such that H_1 is geometric in $\tilde{\mathcal{O}}$ and H_2 is not conjugate into the image of $\pi_1(\tilde{\mathcal{O}})$ under the natural embedding of fundamental groups $\pi_1(\tilde{\mathcal{O}}) \rightarrow \pi_1(\mathcal{O})$. For this construction, we will create suitable covering pieces of the 2-dimensional sub-orbifolds which are obtained from the mentioned decomposition of \mathcal{O} . For this we need the following statements.

Recall that if \mathcal{S} is a compact surface of genus $g(\mathcal{S})$ with $n \in \mathbb{N}$ boundary components, then $\chi(\mathcal{S}) = 2 - 2g(\mathcal{S}) - n$ if \mathcal{S} is orientable and $\chi(\mathcal{S}) = 1 - g(\mathcal{S}) - n$ if not. Following [5], page 113 pp., similarly one can define the Euler characteristic for compact orientable orbifolds:

Definition 6.29. *Let $\mathcal{C} = (\Sigma; p_1, \dots, p_m)$ be a compact orientable 2-orbifold with underlying surface Σ of genus $g(\Sigma)$ with boundary components R_1, \dots, R_n and cone points P_r of order $p_r \in \mathbb{N}$ f.a. $r \in \{1, \dots, m\}$.*

1. We set $g(\mathcal{C}) := g(\Sigma)$.
2. The Euler characteristic of \mathcal{C} is defined as

$$\chi(\mathcal{C}) = \chi(\Sigma) - \sum_{r=1}^m \left(1 - \frac{1}{p_r}\right) = 2 - 2g(\mathcal{C}) - n - \sum_{r=1}^m \left(1 - \frac{1}{p_r}\right).$$

If $G := \pi_1(\mathcal{C})$ we set $\chi(G) := \chi(\mathcal{C})$.

Note that $\chi(\mathcal{O}) < 0$ if and only if \mathcal{O} is hyperbolic, for details see [5] Proposition 2.6 on page 114. Moreover the Euler characteristic is well-behaved when passing to subgroups of finite index, namely if $|G : U| = d$ then $\chi(G) = d \cdot \chi(U)$ (for details see again [5], page 113 pp.). Clearly any finite index subgroup corresponds to a finite-sheeted orbifold covering. The following statements deal with some special finite-sheeted coverings of surfaces and orbifolds, where it is completely determinable of which degrees the boundary components are covered.

The following lemma was proved first by D. Husemoller in [19] und reproved in [11]. It is not valid for \mathcal{S} if $g(\mathcal{S}) = 0$. The corresponding problem is called *Hurwitz realizability problem for branched coverings of surfaces*, see [18] It is not solved yet in general, see [28], [29], [30] and [11].

Proposition 6.30. *Let \mathcal{S} be a compact orientable surface of genus $g(\mathcal{S}) \geq 1$ with boundary components R_1, \dots, R_n . Let $\tilde{\mathcal{S}}$ be a compact orientable surface with boundary components $R_{i,j}$ and associated natural numbers $d_{i,j}$ for every $i \in \{1, \dots, n\}$, $j \in \{1, \dots, k_i\}$. Then there exists a covering $\tilde{\mathcal{S}} \rightarrow \mathcal{S}$ of degree d such that $R_{i,j}$ covers R_i with degree $d_{i,j}$ if and only if the following conditions are satisfied.*

- 1) $\chi(\tilde{\mathcal{S}}) = d \cdot \chi(\mathcal{S})$,
- 2) $d = \sum_{j=1}^{k_i} d_{i,j}$ for every $i \in \{1, \dots, n\}$. □

Clearly there is a close relationship between surface coverings and orbifold coverings. One can create an orbifold covering by treating the cone points as ordinary boundary components with the following restriction: A cone point of rotation order p can be covered of degree d if and only if d divides p . Therefore the following Corollary is an immediate consequence of Proposition 6.30:

Corollary 6.31. *Let $\mathcal{C} = (\Sigma; p_1, \dots, p_m)$ be a compact orientable 2-orbifold with underlying surface Σ of genus $g(\Sigma) \geq 1$ with boundary components R_1, \dots, R_n and cone points P_r of order $p_r \in \mathbb{N}$ f.a. $r \in \{1, \dots, m\}$. Let $\tilde{\mathcal{C}} = (\tilde{\Sigma}; p_{1,1}, \dots, p_{1,t_1}, \dots, p_{r,1}, \dots, p_{r,t_r})$ be a compact orientable 2-orbifold with underlying surface $\tilde{\Sigma}$ with boundary components $R_{i,j}$ with associated natural numbers $d_{i,j}$ for every $i \in \{1, \dots, n\}$, $j \in \{1, \dots, k_i\}$ and cone points $P_{s,r}$ with associated natural numbers $p_{r,s}$ for every $r \in \{1, \dots, m\}$, $s \in \{1, \dots, t_r\}$. Then there exists a covering $\tilde{\mathcal{C}} \rightarrow \mathcal{C}$ of degree d such that $R_{i,j}$ covers R_i with degree $d_{i,j}$ and $P_{r,s}$ covers P_r with degree $p_{r,s}$ if and only if the following conditions are satisfied.*

- 1) $\chi(\tilde{\mathcal{C}}) = d \cdot \chi(\mathcal{C})$,
- 2) $d = \sum_{j=1}^{k_i} d_{i,j}$ for every $i \in \{1, \dots, n\}$.
- 3) For any $r \in \{1, \dots, m\}$ we have $p_{r,s} | p_r$ for all $s \in \{1, \dots, t_r\}$.
- 4) $d = \sum_{s=1}^{t_r} \frac{p_r}{p_{r,s}}$ for every $r \in \{1, \dots, m\}$. □

The following proposition was proved by A.L. Edmonds, R.S. Kulkarni and R.E. Stong in [11].

Proposition 6.32. *Let \mathcal{S} be a compact orientable surface of genus $g(\mathcal{S}) = 0$ with boundary components R_1, \dots, R_n , $n \geq 3$. Let $\tilde{\mathcal{S}}$ be a compact orientable surface with boundary components $R_{i,j}$ and associated natural numbers $d_{i,j}$ for every $i \in \{1, \dots, n\}$, $j \in \{1, \dots, k_i\}$ such that $k_i = 1$ and $d_{i,1} = d$ for some $i \in \{1, \dots, n\}$. Then there exists a covering $\tilde{\mathcal{S}} \rightarrow \mathcal{S}$ of degree d such that $R_{i,j}$ covers R_i with degree $d_{i,j}$ if and only if the following conditions are satisfied.*

- 1) $\chi(\tilde{\mathcal{S}}) = d \cdot \chi(\mathcal{S})$,
- 2) $d = \sum_{j=1}^{k_i} d_{i,j}$ for every $i \in \{1, \dots, n\}$. □

We observe the following consequence for orbifold coverings:

Corollary 6.33. *Let $\mathcal{C} = (\Sigma; p_1, \dots, p_m)$ be a compact orientable 2-orbifold with underlying surface Σ of genus $g(\Sigma) = 0$ with boundary components R_1, \dots, R_n and cone points P_r of order $p_r \in \mathbb{N}$ f.a. $r \in \{1, \dots, m\}$. Assume that $n + m \geq 3$ and let $\tilde{\mathcal{C}} = (\tilde{\Sigma}; p_{1,1}, \dots, p_{1,t_1}, \dots, p_{r,1}, \dots, p_{r,t_r})$ be a compact orientable 2-orbifold with underlying surface $\tilde{\Sigma}$ with boundary components $R_{i,j}$ with associated natural numbers $d_{i,j}$ for every $i \in \{1, \dots, n\}$, $j \in \{1, \dots, k_i\}$ and cone points $P_{s,r}$ with associated natural numbers $p_{r,s}$ for every $r \in \{1, \dots, m\}$, $s \in \{1, \dots, t_r\}$ such that $k_i = 1$ and $d_{i,1} = d$ for some $i \in \{1, \dots, n\}$ or $t_r = 1$ and $p_{r,1} = d$ for some $r \in \{1, \dots, m\}$. Then there exists a covering $\tilde{\mathcal{C}} \rightarrow \mathcal{C}$ of degree d such that $R_{i,j}$ covers R_i with degree $d_{i,j}$ and $P_{r,s}$ covers P_r if and only if the following conditions are satisfied.*

- 1) $\chi(\tilde{\mathcal{C}}) = d \cdot \chi(\mathcal{C})$,

$$2) d = \sum_{j=1}^{k_i} d_{i,j} \text{ for every } i \in \{1, \dots, n\}.$$

$$3) \text{ For any } r \in \{1, \dots, m\} \text{ we have } p_{r,s} | p_r \text{ for all } s \in \{1, \dots, t_r\}.$$

$$4) d = \sum_{s=1}^{t_r} \frac{p_r}{p_{r,s}} \text{ for every } r \in \{1, \dots, m\}. \quad \square$$

As before the following proposition, again a proof can be found in [11], is translatable into the 2-orbifold case:

Proposition 6.34. *Let \mathcal{S} be a compact orientable surface of genus $g(\mathcal{S}) = 0$ with boundary components R_1, \dots, R_n , $n \geq 3$. Let $\tilde{\mathcal{S}}$ be a compact orientable surface with boundary components $R_{i,j}$ and associated natural numbers $d_{i,j}$ for every $i \in \{1, \dots, n\}$, $j \in \{1, \dots, k_i\}$ such that $k_i = 2$, $d_{i,1} = d - 1$ and $d_{i,2} = 1$ for some $i \in \{1, \dots, n\}$. Then there exists a covering $\tilde{\mathcal{S}} \rightarrow \mathcal{S}$ of degree d such that $R_{i,j}$ covers R_i with degree $d_{i,j}$ if the following conditions are satisfied.*

$$1) \chi(\tilde{\mathcal{S}}) = d \cdot \chi(\mathcal{S}),$$

$$2) d = \sum_{j=1}^{k_i} d_{i,j} \text{ for every } i \in \{1, \dots, n\}.$$

$$3) n \geq 4 \text{ or } d \neq 4. \quad \square$$

Corollary 6.35. *Let $\mathcal{C} = (\Sigma; p_1, \dots, p_m)$ be a compact orientable 2-orbifold with underlying surface Σ of genus $g(\Sigma) = 0$ with boundary components R_1, \dots, R_n and cone points P_r of order $p_r \in \mathbb{N}$ f.a. $r \in \{1, \dots, m\}$. Let $\tilde{\mathcal{C}} = (\tilde{\Sigma}; p_{1,1}, \dots, p_{1,t_1}, \dots, p_{r,1}, \dots, p_{r,t_r})$ be a compact orientable 2-orbifold with underlying surface $\tilde{\Sigma}$ with boundary components $R_{i,j}$ with associated natural numbers $d_{i,j}$ for every $i \in \{1, \dots, n\}$, $j \in \{1, \dots, k_i\}$ and cone points $P_{r,s}$ with associated natural numbers $p_{r,s}$ for every $r \in \{1, \dots, m\}$, $s \in \{1, \dots, t_r\}$ such that $k_i = 2$, $d_{i,1} = d - 1$ and $d_{i,2} = 1$ for some $i \in \{1, \dots, n\}$ or $t_r = 2$, $p_{r,1} = d - 1$ and $p_{r,2} = 1$ for some $r \in \{1, \dots, m\}$. Then there exists a covering $\tilde{\mathcal{C}} \rightarrow \mathcal{C}$ of degree d such that $R_{i,j}$ covers R_i with degree $d_{i,j}$ and $P_{r,s}$ covers P_r of degree $p_{r,s}$ if the following conditions are satisfied.*

$$1) \chi(\tilde{\mathcal{C}}) = d \cdot \chi(\mathcal{C}),$$

$$2) d = \sum_{j=1}^{k_i} d_{i,j} \text{ for every } i \in \{1, \dots, n\}.$$

$$3) \text{ For any } r \in \{1, \dots, m\} \text{ we have } p_{r,s} | p_r \text{ for all } s \in \{1, \dots, t_r\}.$$

$$4) d = \sum_{s=1}^{t_r} \frac{p_r}{p_{r,s}} \text{ for every } r \in \{1, \dots, m\}.$$

$$5) n + m \geq 4 \text{ or } d \neq 4. \quad \square$$

We receive the following consequence:

Corollary 6.36. *Let $\mathcal{C} = (\Sigma; p_1, \dots, p_m)$ be a compact orientable 2-orbifold with underlying surface Σ of genus $g(\Sigma) = 0$ with only one boundary component R_1 and cone points P_r of order $p_r \in \mathbb{N}$ f.a. $r \in \{1, \dots, m\}$. If $m = 2$ and $p_1 = p_2 = 2$ we set $d = 2$. Else let $d := 2 \prod_{r=1}^m p_r$. Then the branching data*

$$(R_1(d-1, 1), P_1(\underbrace{p_1, \dots, p_1}_{d/p_1}), \dots, P_m(\underbrace{p_m, \dots, p_m}_{d/p_m}))$$

is realizable by a covering $\tilde{\mathcal{C}} \rightarrow \mathcal{C}$ and $\tilde{\mathcal{C}}$ can be regarded as a surface.

Proof: If $m = d = 2$, we can apply Corollary 6.33 and therefore the required covering is realizable by a surface $\tilde{\mathcal{C}}$ with $g(\tilde{\mathcal{C}}) = 0$. If $m \geq 2$, we can use Corollary 6.35 and hence the desired covering is realizable by a surface of genus $g(\tilde{\Sigma}) = p \cdot (m - 1 - \sum_{r=1}^m \frac{1}{p_r}) \in \mathbb{N}$ for $p := \prod_{r=1}^m p_r$. \square

Lemma 6.37. *Let $\mathcal{O} = (\Theta, s_1, \dots, s_k)$ be a closed orientable 2-orbifold with $\chi(\mathcal{O}) < 0$. Assume that \mathcal{O} splits into two incompressible sub-2-orbifolds \mathcal{C} and \mathcal{D} . Then there exists a finite-sheeted covering $\tilde{\mathcal{O}} \rightarrow \mathcal{O}$ such that \mathcal{C} and \mathcal{D} can be realized as sub-2-orbifolds of $\tilde{\mathcal{O}}$ satisfying the condition that both have only one complementary region $\hat{\mathcal{C}}$ and $\hat{\mathcal{D}}$, respectively, in $\tilde{\mathcal{O}}$ such that $g(\hat{\mathcal{C}}) \geq 1 \leq g(\hat{\mathcal{D}})$.*

Proof: So let $\mathcal{D} = (\Lambda; q_1, \dots, q_l)$ with cone points Q_j of order $q_j \in \mathbb{N}$ f.a. $j \in \{1, \dots, l\}$ and boundary components S_1, \dots, S_n and $\mathcal{C} = (\Sigma; p_1, \dots, p_m)$ with cone points P_j of order $p_j \in \mathbb{N}$ f.a. $j \in \{1, \dots, m\}$ and boundary components R_1, \dots, R_n in \mathcal{O} . Let $q = \prod_{j=1}^l q_j$ and $p = \prod_{r=1}^m p_r$. We distinguish three cases:

1) $n \geq 3$: Note that in any case there exists some $d \in \mathbb{N}$ such that the branching data

$$(R_1(d), R_2(\underbrace{1, \dots, 1}_d), \dots, R_n(\underbrace{1, \dots, 1}_d), P_1(\underbrace{1, \dots, 1}_d), \dots, P_m(\underbrace{1, \dots, 1}_d))$$

are realizable by a cover $\tilde{\mathcal{C}} \rightarrow \mathcal{C}$. Either by applying Corollary 6.31 if $g(\mathcal{C}) \geq 1$ or by Corollary 6.33 in the case where $g(\mathcal{C}) = 0$.

Similarly it follows that there exists a cover $\tilde{\mathcal{D}} \rightarrow \mathcal{D}$ with the branching data

$$(S_1(d), S_2(\underbrace{1, \dots, 1}_d), \dots, S_n(\underbrace{1, \dots, 1}_d), Q_1(\underbrace{1, \dots, 1}_d), \dots, Q_l(\underbrace{1, \dots, 1}_d)).$$

Clearly one can glue a copy of \mathcal{C} , \mathcal{D} , $\tilde{\mathcal{C}}$ and $\tilde{\mathcal{D}}$ together to create a cover $\tilde{\mathcal{O}} \rightarrow \mathcal{O}$ which has the desired properties:

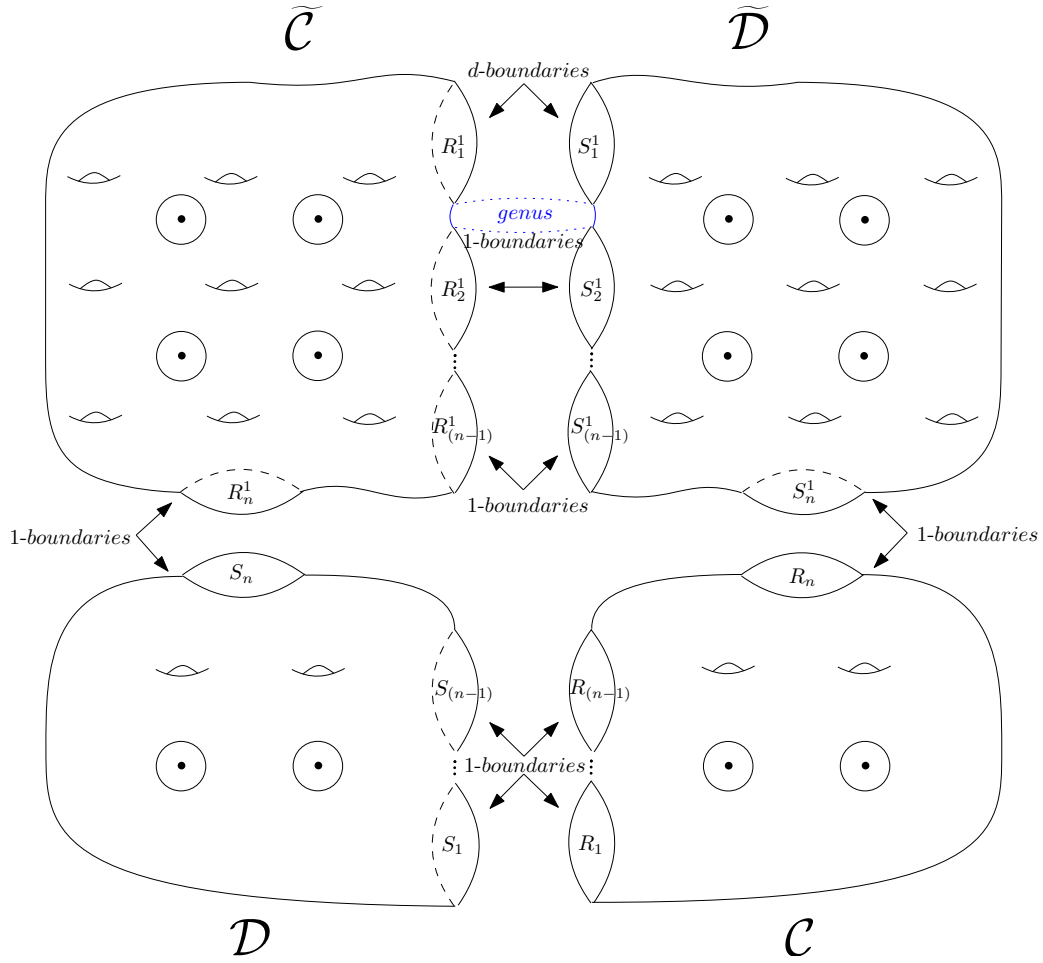

Figure 10: After gluing a copy of $\mathcal{C}, \mathcal{D}, \tilde{\mathcal{C}}$ and $\tilde{\mathcal{D}}$ together, we receive the 2-orbifold $\tilde{\mathcal{O}}$.

- 2) $n = 1$. Let \mathcal{H} be the orbifold with only one boundary component, exactly two cone points of order two and $g(\mathcal{E}) = 0$. Note that an easy calculation shows that a compact 2-dimensional orbifold \mathcal{K} with one boundary component is homeomorphic to \mathcal{H} if and only if $\chi(\mathcal{K}) = 0$. Since $\chi(\mathcal{O}) < 0$, \mathcal{O} is not the pillow orbifold. Thus as \mathcal{C} and \mathcal{D} are incompressible it follows that at least one of both, \mathcal{C} or \mathcal{D} is not homeomorphic to the orbifold \mathcal{H} , i.e. $\chi(\mathcal{C}) < 0$ or $\chi(\mathcal{D}) < 0$.

Case 1: Assume that both \mathcal{C} and \mathcal{D} , are not homeomorphic to \mathcal{H} .

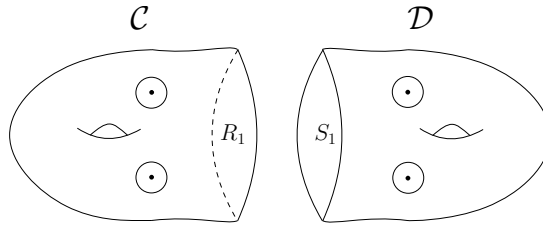

Figure 11: The two sub-2-orbifolds \mathcal{C} and \mathcal{D} .

Then by Corollary 6.36 there exists a cover $\tilde{\mathcal{C}} \rightarrow \mathcal{C}$ realizing the branching data

$$(R_1(2p-1, 1), P_1(\underbrace{p_1, \dots, p_1}_{2p/p_1}), \dots, P_m(\underbrace{p_m, \dots, p_m}_{2p/p_m})).$$

Note that $\tilde{\mathcal{C}}$ can be regarded as a surface and that an easy Euler characteristic argument shows that $g(\tilde{\mathcal{C}}) \geq 1$, since $\chi(\mathcal{C}) < 0$. Let R_1^1 be the boundary of $\tilde{\mathcal{C}}$ which covers R_1 of degree 1 and R_1^2 be the degree $(2p - 1)$ cover of R_1 in $\tilde{\mathcal{C}}$.

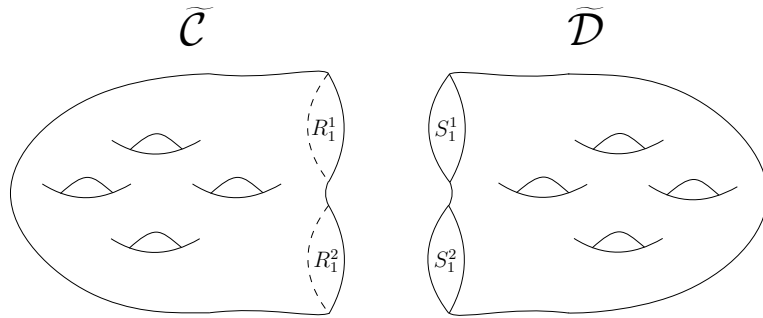

Figure 12: The two covers $\tilde{\mathcal{C}}$ and $\tilde{\mathcal{D}}$ can be regarded as surfaces.

By Proposition 6.30 the branching data $(R_1^1(2q - 1, 1), R_1^2(2q - 1, 1))$ is realized by a cover $\hat{\mathcal{C}} \rightarrow \tilde{\mathcal{C}}$. By analyzing the induced cover $\hat{\mathcal{C}} \rightarrow \mathcal{C}$ we see that $\hat{\mathcal{C}}$ has exactly four boundary components which are covers of R_1 in \mathcal{C} of degrees $(2q - 1)$, $(2p - 1)$, $(2p - 1) \cdot (2q - 1)$ and 1.

In the same way we create a similar covering $\hat{\mathcal{D}}$ of \mathcal{D} . Gluing $\hat{\mathcal{C}}$, $\hat{\mathcal{D}}$, a copy of \mathcal{D} and a copy of \mathcal{C} together in the obvious way induces now the desired covering of \mathcal{O} :

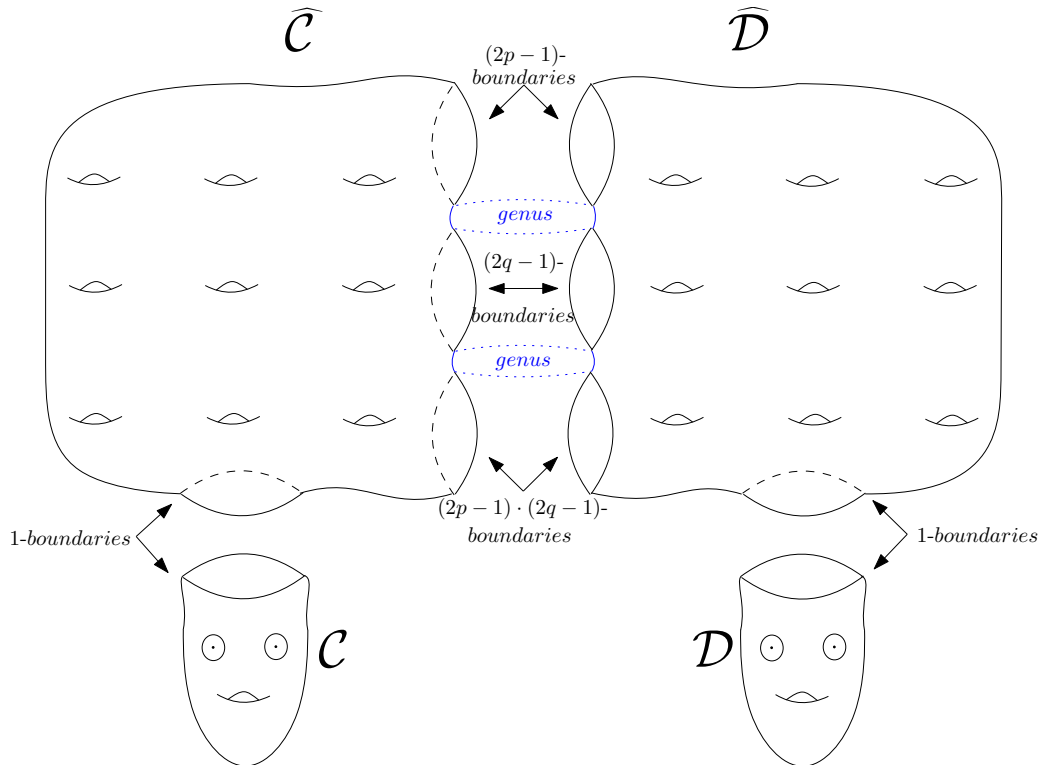

Figure 13: Gluing a copy of \mathcal{C} , \mathcal{D} , $\hat{\mathcal{C}}$ and $\hat{\mathcal{D}}$ together provides the desired cover $\tilde{\mathcal{O}}$ of \mathcal{O} .

Case 2: Let $n = 1$ and assume that $\chi(\mathcal{C}) = 0$.

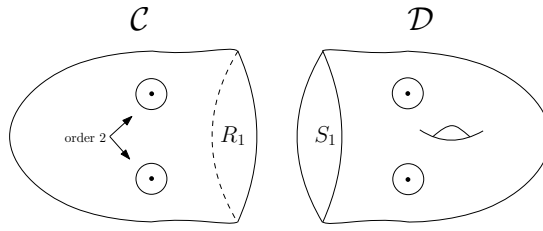

Figure 14: The two sub-2-orbifolds \mathcal{C} and \mathcal{D} where \mathcal{C} is homeomorphic to \mathcal{E} .

Then by Corollary 6.36, the branching data $(R_1(1, 1), P_1(2), P_2(2))$ is realized by a cover $\tilde{\mathcal{C}} \rightarrow \mathcal{C}$ satisfying $g(\tilde{\mathcal{C}}) = 0$. Hence we can find a surface cover $\hat{\mathcal{C}}$ of \mathcal{C} which has exactly two boundaries, which are both covers of R_1 of degree $(2q - 1)$. On the other hand, since \mathcal{D} is not homeomorphic to \mathcal{H} , we can create $\hat{\mathcal{D}}$ as in the case before for $p = 1$. Hence $\hat{\mathcal{D}}$ has exactly four covers of the boundary S_1 ; two of degree $(2q - 1)$ and two degree 1 boundaries. Now we glue two copies of $\hat{\mathcal{D}}$ along two copies of $\hat{\mathcal{C}}$ together. The resulting space \mathcal{E} satisfies $g(\mathcal{E}) \geq 1$ and has only four boundary components corresponding to degree 1 covers of S_1 . We glue two copies of \mathcal{C} and two copies of $\tilde{\mathcal{C}}$ to \mathcal{E} . The resulting space $\tilde{\mathcal{E}}$ has only two boundaries corresponding to degree 1 covers of R_1 . To finish we glue two copies of \mathcal{D} along these two degree 1 boundaries to $\tilde{\mathcal{E}}$.

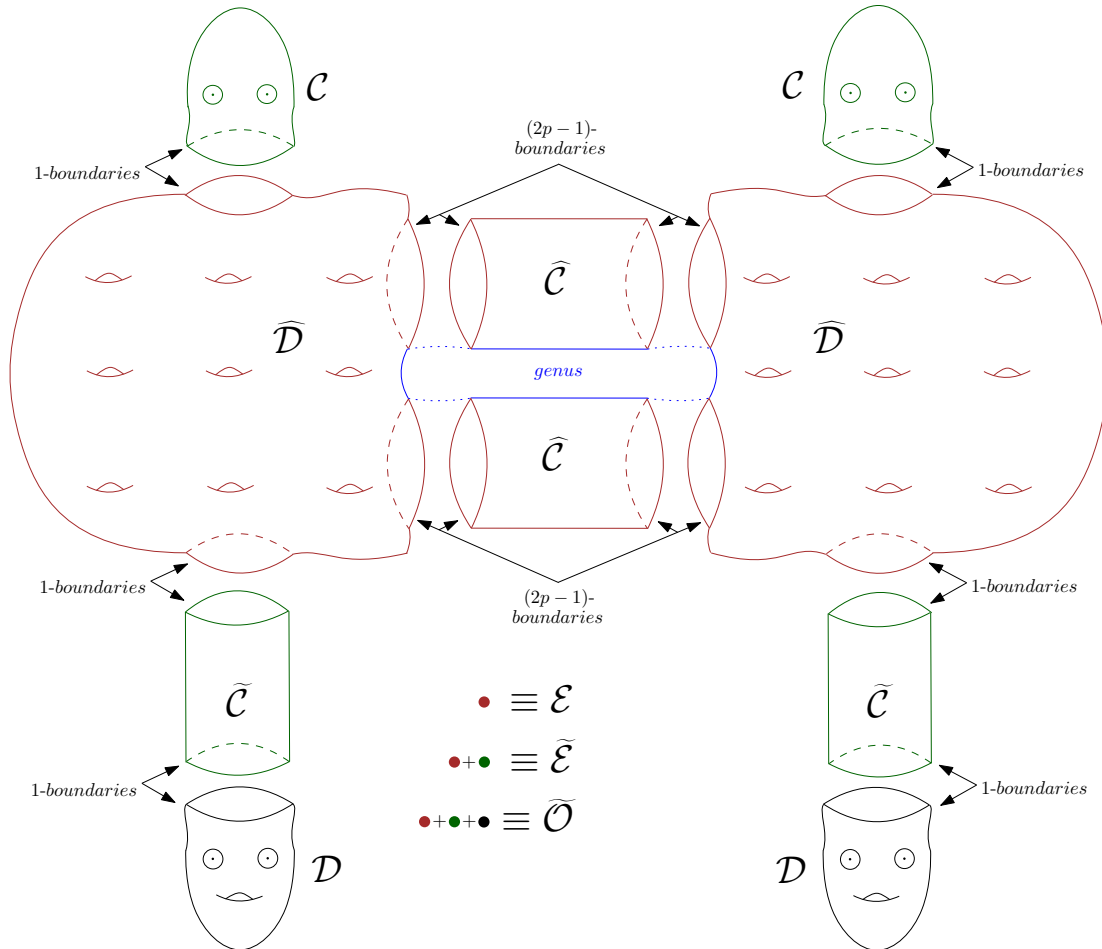

Figure 15: The resulting space $\tilde{\mathcal{O}}$, which induces by construction the desired covering.

3) Let $n = 2$.

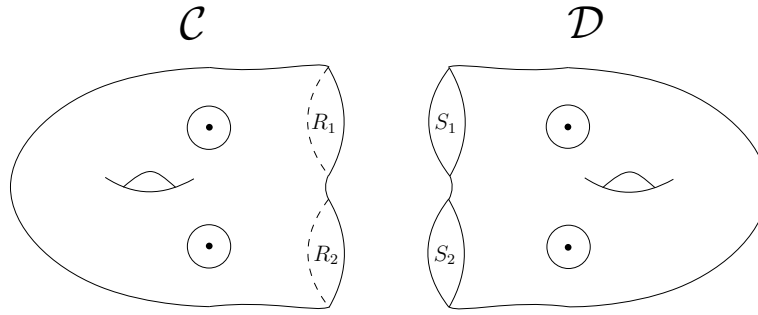

Figure 16: The two sub-2-orbifolds \mathcal{C} and \mathcal{D} with two boundary components.

If either $g(\mathcal{C}) \geq 1$ or $g(\mathcal{D}) \geq 1$ the result is trivial, because we can glue two copies of \mathcal{C} and two copies of \mathcal{D} together to obtain the required covering space $\tilde{\mathcal{O}}$ of \mathcal{O} :

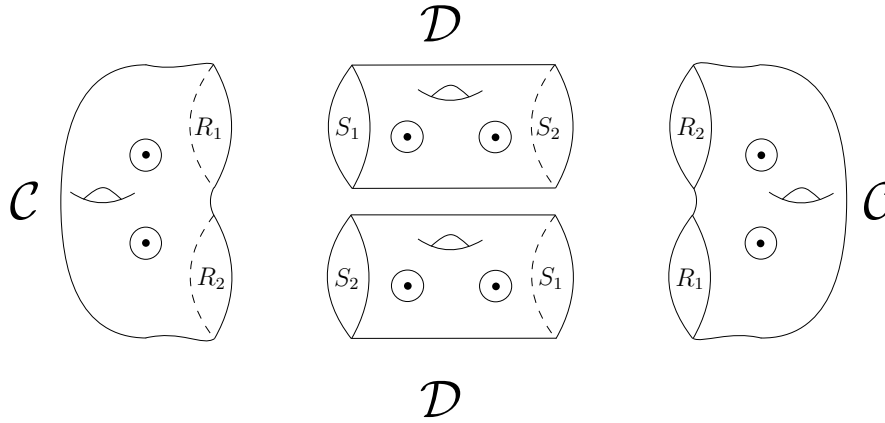

Figure 17: The trivial case: $g(\mathcal{C}) \geq 1$ or $g(\mathcal{D}) \geq 1$.

So suppose that $g(\mathcal{C}) = 0 = g(\mathcal{D})$. Since $\chi(\mathcal{O}) < 0$ we can assume that \mathcal{O} is unequal to a torus. So at least one of the two sub-2-orbifolds has cone points.

Case 1: Let $l \neq 0 \neq m$. Then we can apply Corollary 6.33 to \mathcal{C} and \mathcal{D} . Therefore the branching data

$$(R_1(d), (R_2(d-2, 1, 1), P_1(\underbrace{p_1, \dots, p_1}_{d/p_1}), \dots, P_m(\underbrace{p_m, \dots, p_m}_{d/p_m})))$$

and

$$(R_1(d-2, 1, 1), (R_2(d), P_1(\underbrace{p_1, \dots, p_1}_{d/p_1}), \dots, P_m(\underbrace{p_m, \dots, p_m}_{d/p_m})))$$

for $d = 2pq$ are realizable by covers $\tilde{\mathcal{C}}$ and $\hat{\mathcal{C}}$, respectively.

Similar the branching data

$$(S_1(d), (S_2(d-2, 1, 1), Q_1(\underbrace{q_1, \dots, q_1}_{d/q_1}), \dots, Q_l(\underbrace{q_l, \dots, q_l}_{d/q_l})))$$

and

$$(S_1(d-2, 1, 1), S_2(d), Q_1(\underbrace{q_1, \dots, q_1}_{d/q_1}), \dots, Q_l(\underbrace{q_l, \dots, q_l}_{d/q_l})))$$

for $d = 2pq$ are realizable by covers $\tilde{\mathcal{D}}$ and $\hat{\mathcal{D}}$, respectively. Hence we can create $\tilde{\mathcal{O}}$ as shown in the following figure:

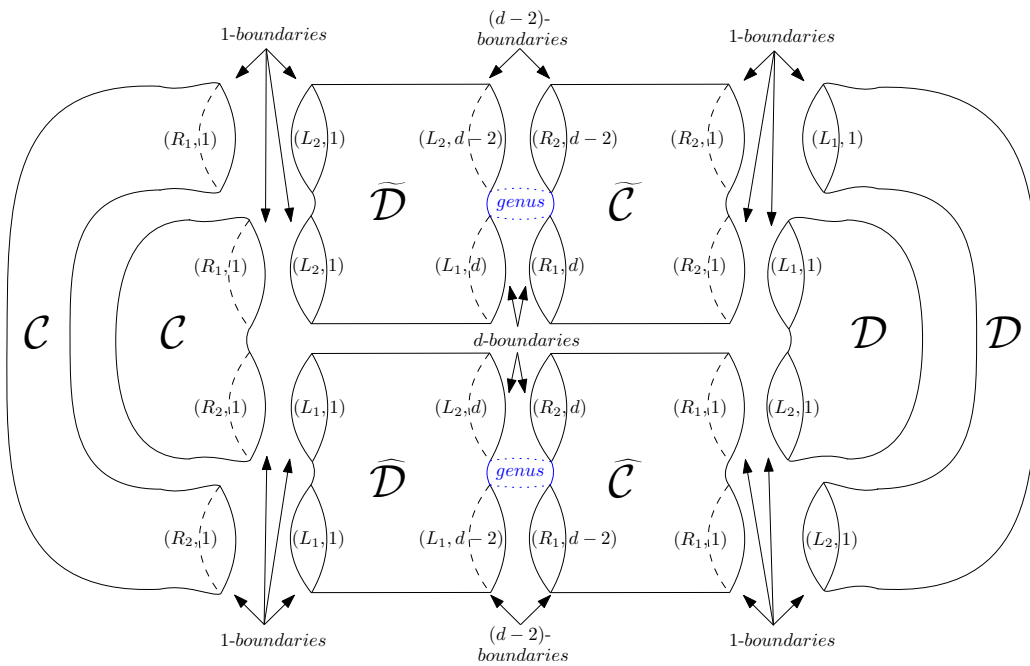

Figure 18: The case where both of the two sub-2-orbifolds \mathcal{C} and \mathcal{D} have at least one cone point.

Case 2: If only one sub-2-orbifold has cone points, say \mathcal{D} , we set $d := 2q$. Clearly we can create the covers $\tilde{\mathcal{D}}$ and $\hat{\mathcal{D}}$ as before and since $g(\mathcal{C}) = 0$ and \mathcal{C} has no cone points, it is a cylinder. Hence the fundamental group of \mathcal{C} is isomorphic to \mathbb{Z} . Let $\tilde{\mathcal{C}}$ be the covering of \mathcal{C} corresponding to the cyclic subgroup of index d and $\hat{\mathcal{C}}$ the cover of \mathcal{C} corresponding to the unique subgroup of index $(d-2)$ of $\pi_1(\mathcal{C})$. Then we can create the cover $\tilde{\mathcal{O}}$ of \mathcal{O} as shown in the following picture and we are done:

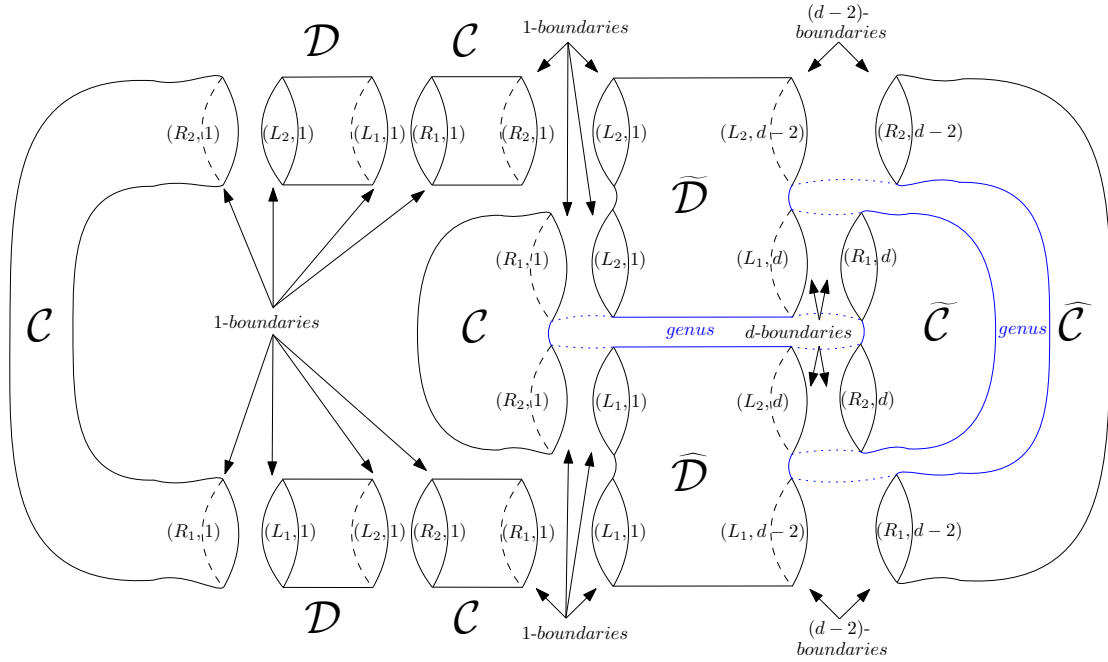

Figure 19: The case where only \mathcal{D} has at least one cone point. □

Corollary and Definition 6.38. *Let $\mathcal{O} = (\Theta, s_1, \dots, s_k)$ be a closed orientable 2-orbifold with $\chi(\mathcal{O}) < 0$. Let \mathcal{C} be an incompressible sub-2-orbifold, such that $\mathcal{O} \setminus \mathcal{C}$ consists of $n \in \mathbb{N}$ disjoint connected components $\mathcal{D}_1, \dots, \mathcal{D}_n$. Then there exists a finite-sheeted covering $\tilde{\mathcal{O}} \rightarrow \mathcal{O}$ such that \mathcal{C} can be realized as **2-dimensional sub-orbifold of a good shape**, i.e. \mathcal{C} has only one complementary region in $\tilde{\mathcal{O}}$, say \mathcal{D} , such that $g(\mathcal{D}) \geq 1$.*

Proof: For the proof we use induction over $n \in \mathbb{N}$. If $n = 1$ the statement is a direct consequence of Lemma 6.37. So let $n \geq 2$ and \mathcal{C} be an incompressible sub-2-orbifold, such that $\mathcal{O} \setminus \mathcal{C}$ consists of $n \in \mathbb{N}$ disjoint connected components $\mathcal{D}_1, \dots, \mathcal{D}_n$. Consider the sub-2-orbifold \mathcal{C}' of \mathcal{O} consisting of the union of \mathcal{C} and \mathcal{D}_n . Then \mathcal{C}' has exactly $n - 1$ disjoint complementary regions in \mathcal{O} , namely $\mathcal{D}_1, \dots, \mathcal{D}_{n-1}$.

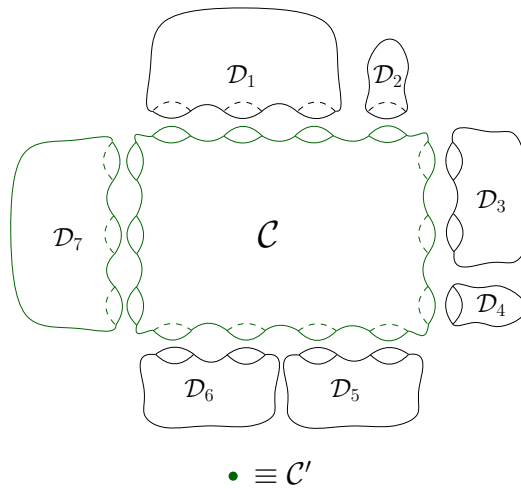

Figure 20: The case where $n = 7$: The sub-2-orbifold \mathcal{C}' consisting of \mathcal{C} and \mathcal{D}_7 has exactly $n - 1 = 6$ complementary regions.

By induction hypothesis there exists a finite-sheeted cover $\mathcal{O}' \rightarrow \mathcal{O}$ such that \mathcal{C}' can be realized as sub-2-orbifold of \mathcal{O}' with only one complementary region \mathcal{D}' satisfying $g(\mathcal{D}') \geq 1$.

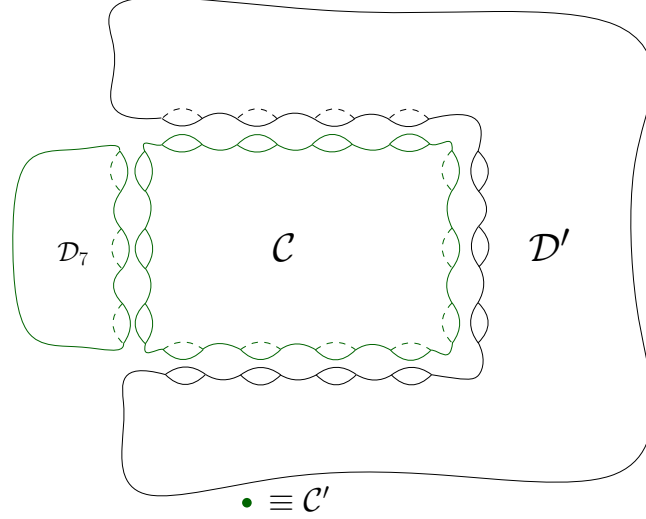

Figure 21: By induction there exists the desired cover for \mathcal{C}' .

Now we are able to apply Lemma 6.37 to $\mathcal{O}' \setminus \mathcal{D}_n$ in \mathcal{O}' . This provides a cover $\widehat{\mathcal{O}} \rightarrow \mathcal{O}'$, with the property that the copy of \mathcal{C} in $\widehat{\mathcal{O}}$, has exactly two complementary regions, say $\widehat{\mathcal{D}}_1$ and $\widehat{\mathcal{D}}_2$, satisfying $g(\widehat{\mathcal{D}}_1) \geq 1 \leq g(\widehat{\mathcal{D}}_2)$.

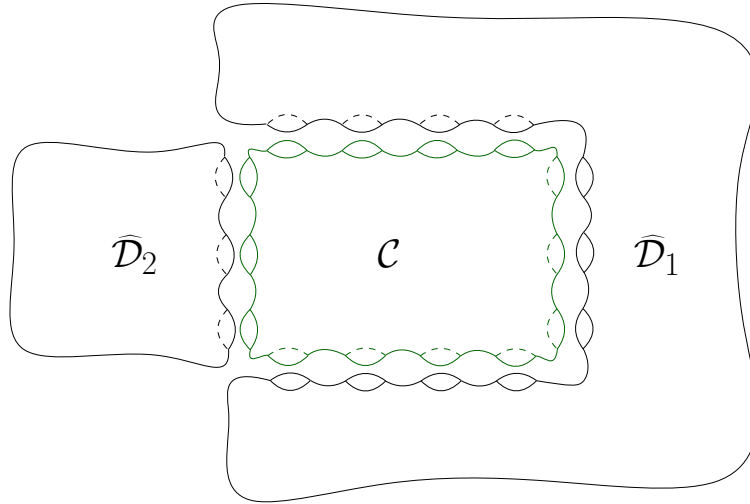

Figure 22: The cover $\widehat{\mathcal{O}}$ provided by applying Lemma 6.37.

We deduce by applying Corollary 6.31 to $\widehat{\mathcal{D}}_1$ and $\widehat{\mathcal{D}}_2$ that there exists $m \in \mathbb{N}$, such that we can create covers $\widetilde{\mathcal{D}}_1$ and $\widetilde{\mathcal{D}}_2$ of $\widehat{\mathcal{D}}_1$ and $\widehat{\mathcal{D}}_2$, respectively, with the property that any boundary component of $\widetilde{\mathcal{D}}_i$ has exactly m covers of degree one in $\widetilde{\mathcal{D}}_i$ and no covers of higher degree for $i \in \{1, 2\}$. One can glue a copy of $\widetilde{\mathcal{D}}_1$, $\widetilde{\mathcal{D}}_2$ and m copies $\mathcal{C}_1, \dots, \mathcal{C}_m$ of \mathcal{C} together to obtain the desired cover of $\widetilde{\mathcal{O}}$ of \mathcal{O} :

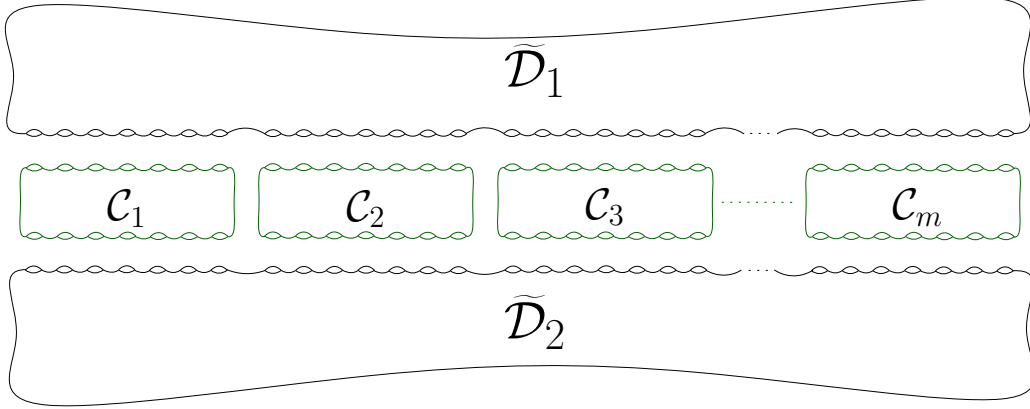

Figure 23: By gluing one copy of $\tilde{\mathcal{D}}_1$ and $\tilde{\mathcal{D}}_2$ and m copies of \mathcal{C} together, we obtain the desired cover $\tilde{\mathcal{O}}$ of \mathcal{O} . \square

Recall that in order to give a proof for Theorem 6.2, i.e. that any Fuchsian group G is SCS, it suffices to prove Theorem 6.28. So assume that $G := \pi_1(\mathcal{O})$ for some 2-dimensional orbifold, which fulfills the requirements of 6.28. In order to prove the con-separability of some finitely generated infinite subgroup H_1 of G by Corollary 6.38 in combination with Lemma 5.6 we can assume that H_1 is realized by a 2-dimensional sub-orbifold \mathcal{A} of \mathcal{O} of good shape, which means that \mathcal{A} has only one complementary region \mathcal{B} with $g(\mathcal{B}) \geq 1$. But this is not the last reduction, we can arrange. For a further reduction we shall use the following well-known facts. Note that the following Lemma is an easy exercise. A proof can be found in [39] on page 65.

Lemma 6.39. *Let G be a finitely generated group acting on a tree T without inversion such that any $g \in G$ fixes a vertex in T . Then there exists global fixed point, i.e. there exists a vertex $v \in VT$ such that $gv = v$ for any $g \in G$.* \square

Suppose that if we are given a 2-dimensional orbifold \mathcal{O} with boundary components R_1, \dots, R_n , $n \in \mathbb{N}$ and fundamental group $G = \pi_1(\mathcal{O})$. Then G admits an action on \mathbb{H}^2 such that the generator g_i corresponding to the boundary component R_i in the presentation of the fundamental group $G := \pi_1(\mathcal{O})$ acts parabolic on \mathbb{H}^2 and therefore generates a parabolic subgroup of G . Clearly the same holds for any conjugate of some g_i , $i \in \mathbb{N}$. Note that this is the case if \mathbb{H}^2/G has finite volume (for details see [23]). While proving the next reduction of the main theorem 6.2 we may use the following statement, which gives information about how a group only consisting of parabolic elements can act on \mathbb{H}^2 . Note that this Lemma is a direct consequence of the proof of theorem 2.4.4 on page 39 combined with Theorem 2.3.5 on page 35 of [23]:

Lemma 6.40. *Any finitely generated Fuchsian group containing only parabolic elements is already parabolic and therefore cyclic.* \square

Using this statement, we receive the following:

Theorem 6.41. *Let \mathcal{O} be a closed orientable 2-orbifold with $\chi(\mathcal{O}) < 0$ and let H_1 be an infinite geometric subgroup of the fundamental group $G = \pi_1(\mathcal{O})$ of \mathcal{O} which is realized by some 2-dimensional-sub-orbifold \mathcal{A} of a good shape. Then H_1 is con-separated from each f.g. subgroup $H_2 \leq G$ not conjugate into H_1 if H_1 is con-separated from each element g not conjugate into H_1 .*

Proof: Let $H_2 \leq G$ be a finitely generated subgroup not conjugate into H_1 . Clearly it suffices to show that if each $x \in H_2$ is conjugate into H_1 we already have that H_2 is conjugate into H_1 . By assumption there exists a suborbifold \mathcal{A} realizing H_1 .

Case 1: If H_1 is non cyclic it follows that \mathcal{A} , the closure of its complement \mathcal{B} , and the common boundary components of \mathcal{A} and \mathcal{B} induce a proper graph of groups decomposition of \mathcal{O} . The group G acts on the associated Bass-Serre tree T . Every element of H_2 has a conjugate in $H_1 = \pi_1(\mathcal{A})$ and hence acts elliptically. Thus it follows by 6.39 that H_2 has a global fixed vertex in T since H_2 is finitely generated. If H_2 fixes a vertex corresponding to a conjugate of $\pi_1(\mathcal{A})$, then H_2 is conjugate to H_1 and we are done. So suppose that H_2 fixes a vertex corresponding to a conjugate of $B := \pi_1(\mathcal{B})$. After replacing H_2 by some conjugate of H_2 if necessary, we can assume that $H_2 \leq B$. By assumption each element $x \in H_2$ fixes a vertex corresponding to a conjugate of $\pi_1(\mathcal{A})$ implying that any element $x \in H_2$ fix an edge e_x incident at the vertex $v \in VT$ fixed by B . Clearly $\text{Stab}(e_x) \leq \pi_1(\mathcal{B})$ is generated by some conjugate of some generator corresponding to some boundary component in \mathcal{B} . By the above discussion $\pi_1(\mathcal{B})$ admits an action of \mathbb{H}^2 such that $\text{Stab}(e_x)$ acts parabolic for any $x \in H_2$. By 6.40 it follows that H_2 is parabolic and therefore cyclic. Thus H_2 is conjugate into H_1 since by assumption any element of H_2 is conjugate into H_1 .

Case 2: If H_1 is infinite cyclic it follows that H_1 is the fundamental group of a cylinder and G decomposes as HNN-extension along H_1 , since H_1 has only one complementary region, say \mathcal{B} . Again let T be the associated Bass-Serre tree and let $x \in H_2$. Since x is conjugated into H_1 it follows that x fixes an edge and hence a vertex in T . Again 6.39 implies that H_2 fixes a vertex in T and therefore one can assume after substituting H_2 by some suitable conjugate that $H_2 \leq B := \pi_1(\mathcal{B})$. Proceeding now as in the first case completes the proof. \square

So finally it is sufficient to show the following statement:

Theorem 6.42. *Let \mathcal{O} be a closed orientable 2-orbifold with $\chi(\mathcal{O}) < 0$ and let H_1 be an **infinite geometric subgroup** of the fundamental group $G = \pi_1(\mathcal{O})$ of \mathcal{O} which is realized by some 2-dimensional-sub-orbifold \mathcal{A} of a **good shape**. Then H_1 is **con-separated** from each **element** g not conjugate into H_1 .*

6.4 Proof of Theorem 6.2

As discussed in the previous chapters, it suffices to prove Theorem 6.42 for showing that any f.g. Fuchsian group is SCS (Theorem 6.2). Note that the following proof is based on the ideas of [3], where the authors showed that surface groups are SCS and we will adapt these ideas to the orbifold case. So fix a hyperbolic metric d on \mathbb{H}^2 . Let G be a subgroup of $\text{Isom}^+(\mathbb{H}^2)$ such that $\pi_1(\mathcal{O}) = G$ for some closed orientable hyperbolic 2-dimensional orbifold \mathcal{O} and let H_1 be an infinite geometric subgroup of the fundamental group G which is realized by some 2-dimensional sub-orbifold \mathcal{A} of \mathcal{O} of a good shape. We explain here how to construct for a given $g \in \pi_1(\mathcal{O})$ with $g^x \notin H_1$ for any $x \in \pi_1(\mathcal{O})$ a cover $\tilde{\mathcal{O}}$ of \mathcal{O} which represents a witness of separation $D \leq G$ for g and H_1 . Let R_1, \dots, R_n be all boundary components of $\mathcal{A} = (\Sigma; p_1, \dots, p_m)$ and let $p := \prod_{r=1}^m p_r$. If \mathcal{A} has no cone points, we set $p := 1$. Since G acts properly discontinuously on \mathbb{H}^2 a hyperbolic metric \hat{d} on $\mathbb{H}/G = \mathcal{O}$ is given by

$$\hat{d} : \mathbb{H}^2/G \times \mathbb{H}^2/G \rightarrow \mathbb{R}, (G \cdot x, G \cdot y) \mapsto \min\{d(x', y') \mid x' \in G \cdot x, y' \in G \cdot y\}.$$

W.l.o.g. one can assume that the image of the boundary component R_i under the natural map $\mathcal{A} \rightarrow \mathcal{O}$ is geodesic for any $i \in \{1, \dots, n\}$ (for details see [13]). Let $\varphi : X \rightarrow \mathcal{O}$ be the natural projection. We define the base point o_0 to be the image under φ of some $x \in X$ with the property that $\text{stab}_G(x) = \{1_G\}$ and $\varphi(x) \in \mathcal{A}$ in \mathcal{O} . Define C to be the distance of the points x and gx with respect to the given metric and let γ be the image under φ of the segment $[x, gx]$ of length C . We may assume that γ is the shortest curve in its free homotopy class. A curve in a covering of \mathcal{O} is called C -short, if its length does not exceed C ; otherwise a curve is called C -long. Clearly g is conjugate into a subgroup D if and only if γ has a closed lift $\tilde{\gamma}$ in the 2-orbifold-cover $\tilde{\mathcal{O}} \rightarrow \mathcal{O}$ representing D .

For the construction of a cover $\tilde{\mathcal{O}} \rightarrow \mathcal{O}$, such that $\tilde{\mathcal{O}}$ represents a finite index subgroup D of G , with the property that $g^h \notin D$ for any $h \in G$, we need in addition the following two statements. The first one is Lemma 5.1. and the second one is Lemma 10.6. of [3]:

Lemma 6.43. *Let \mathcal{S} be a compact orientable surface with $\chi(\mathcal{S}) \leq -1$, with a fixed hyperbolic metric, and with $n > 1$ boundary components R_1, \dots, R_n which are geodesics with respect to this metric. Let C_0 be the maximum of lengths of boundary components of \mathcal{S} . For any constant $C > C_0$, there exists an even number K_0 satisfying the following statement: for each multiple of K of K_0 , there exists coverings: $\Theta : \hat{\mathcal{S}} \rightarrow \mathcal{S}$ and $\theta_i : \hat{\mathcal{S}}_i \rightarrow \mathcal{S}$, $i \in \{1, \dots, n\}$, such that:*

(A1) *The branching data of Θ is*

$$(R_1(\underbrace{K, \dots, K}_c), R_2(\underbrace{K, \dots, K}_c), \dots, R_n(\underbrace{K, \dots, K}_c))$$

for some c .

(A2) *There are no nontrivial C -short loops in $\hat{\mathcal{S}}$.*

(A3) *Every C -short geodesic curve in $\hat{\mathcal{S}}$ with endpoints on a boundary component of $\hat{\mathcal{S}}$ lies in this component.*

(B1) There exists $d \in \mathbb{N}$ such that the branching data of each θ_i can be obtained from the n -tuple

$$(R_1(\underbrace{K, \dots, K}_d), R_2(\underbrace{K, \dots, K}_d), \dots, R_n(\underbrace{K, \dots, K}_d))$$

by replacing it's i -th term by $R_i(\underbrace{1, \dots, 1}_{K/2}, K/2, \underbrace{K, \dots, K}_{d-1})$

(B2) Every C -short loop in $\widehat{\mathcal{S}}_i$ is freely homotopic into a 1-boundary of $\widehat{\mathcal{S}}_i$.

(B3) Every C -short geodesic curve in $\widehat{\mathcal{S}}_i$ with endpoints on a 1-boundary of $\widehat{\mathcal{S}}_i$ lies in this 1-boundary.

(B4) The distance between any two 1-boundary components of $\widehat{\mathcal{S}}_i$ is larger than C . \square

For the second statement we use the following definition:

Definition 6.44. *The girth of a graph is defined to be the length of a shortest circuit therein without backtracking. In a forest, such circuits do not exist and we say that forests have infinite girth.*

As mentioned the following statement is proven in [3] (Lemma 10.6). For completeness we repeat the proof.

Lemma 6.45. *Let Γ be a finite connected graph and m be a natural number. Then there exists a finite connected graph $\widetilde{\Gamma}$ which covers Γ and has the girth larger than m .* \square

Proof: Let F be the fundamental group of Γ with respect to some point. We choose a maximal subtree T of Γ . Then F has the (finite) basis X , which corresponds to the set of edges of Γ outside of T . The length function on F with respect to X will be called X -length. Since X is finite there are only finitely many elements of X with X -length smaller or equal to m . Note that F is residually finite, since F is free in X . Thus there exists a finite index subgroup N , which does not contain elements of length up to m . W.l.o.g. we can assume that N is normal in F . Clearly there exists a covering of graphs $\mathfrak{f}: \widehat{\Gamma} \rightarrow \Gamma$ representing N . So suppose that there exists a simple closed curve in $\widehat{\Gamma}$, whose edge-length is smaller than or equal to m . Then the edge-length of it's projection in Γ is smaller than or equal to m . in particular, N contains a nontrivial element of X -length smaller than or equal to m , a contradiction. \square

Let $\mathcal{B} = (\Lambda; q_1, \dots, q_l)$ be the complement of \mathcal{A} in \mathcal{O} and let $q := \prod_{j=1}^m p_j$. If \mathcal{B} has no cone points, we set $q := 1$. Since \mathcal{A} is of a good shape, we have $g(\mathcal{B}) \geq 1$. Hence we can apply Lemma 6.37 to \mathcal{O} to receive a 2-dimensional orbifold $\widetilde{\mathcal{A}}$, such that $g(\widetilde{\mathcal{A}}) \geq 1$ and with the property that $\widetilde{\mathcal{A}}$ has exactly one degree one cover of the boundary R_i for any $i \in \{1, \dots, n\}$. Since $g(\widetilde{\mathcal{A}}) \geq 1$ and $g(\mathcal{B}) \geq 1$ we can apply Corollary 6.31 to $\widetilde{\mathcal{A}}$ and to \mathcal{B} for $d := 2pq$ to obtain covers $\widehat{\mathcal{A}}$ of $\widetilde{\mathcal{A}}$ and $\widehat{\mathcal{B}}$ of \mathcal{B} which satisfy the following important conditions:

- 1) $\widehat{\mathcal{A}}$ and $\widehat{\mathcal{B}}$ can be regarded as ordinary surfaces without any cone points,
- 2) For any $i \in \{1, \dots, n\}$ we have
 - a) $\widehat{\mathcal{A}}$ has exactly $2pq$ degree one covers of the boundary component R_i and these are the only covers of the boundary R_i .
 - b) $\widehat{\mathcal{B}}$ has exactly $2pq$ degree one covers of the boundary component S_i and these are the only covers of the boundary S_i .

This allows us to proceed as in [3] part 8 with the difference that we create special covers of $\widehat{\mathcal{A}}$ and $\widehat{\mathcal{B}}$ instead of \mathcal{A} and \mathcal{B} . We will construct special coverings $\mathcal{B}_1, \dots, \mathcal{B}_{n+2}$ of $\widehat{\mathcal{B}}$ and special coverings \mathcal{A}_{n+1} and \mathcal{A}_{n+2} of $\widehat{\mathcal{A}}$, and then we will construct $\widehat{\mathcal{O}}$ by gluing several copies of these coverings and several copies of \mathcal{A} according to the schema described below.

Construction 6.46 (Special coverings of $\widehat{\mathcal{A}}$ and $\widehat{\mathcal{B}}$). *Let $\widetilde{\mathcal{A}}$ be a covering of $\widehat{\mathcal{A}}$. A boundary component of $\widetilde{\mathcal{A}}$ is called an (R_i, d) -boundary if it covers the related boundary component R_i of \mathcal{A} with degree d . We use the same definition for $\widehat{\mathcal{B}}$ instead of $\widehat{\mathcal{A}}$. Sometimes we will shorten this wording to d -boundary. Note that the surfaces $\widehat{\mathcal{A}}$ and $\widehat{\mathcal{B}}$ have already exactly $2pq$ boundaries of type $(R_i, 1)$ and $(S_i, 1)$ respectively for any $i \in \{1, \dots, n\}$. Because of this we can create by applying Lemma 6.43 coverings $\mathcal{B}_1, \dots, \mathcal{B}_{n+2}$ of $\widehat{\mathcal{B}}$ and coverings $\mathcal{A}_{n+1}, \mathcal{A}_{n+2}$ of $\widehat{\mathcal{A}}$ which satisfy the following two conditions:*

1. *Condition on boundaries: There are natural numbers M, N, N', N'' such that $M > 1$ and the following holds:*
 - i) *For each $i \in \{1, \dots, n\}$ the surface \mathcal{B}_i contains exactly M boundary components of type $(R_i, 1)$, N boundary components of type (R_i, M) , N' boundary components of type $(R_i, 2M)$, N'' boundary components of type $(R_j, 2M)$ for each $j \in \{1, \dots, n\} \setminus \{i\}$.*
 - ii) *The surfaces \mathcal{A}_{n+1} and \mathcal{B}_{n+1} contain only boundary components of type (R_j, M) for each $j \in \{1, \dots, n\}$. Clearly, the number of such components for each j is the same.*
 - iii) *The surfaces \mathcal{A}_{n+2} and \mathcal{B}_{n+2} contain only boundary components of type $(R_j, 2M)$ for each $j \in \{1, \dots, n\}$. Clearly, the number of such components of type $(R_j, 2M)$ for each $j \in \{1, \dots, n\}$. Clearly, the number of such components for each j is the same.*
2. *Condition on short curves: For every $\mathcal{K} \in \{\mathcal{A}_{n+1}, \mathcal{B}_{n+1}, \mathcal{A}_{n+2}, \mathcal{B}_{n+2}\} \cup \{\mathcal{B}_1, \dots, \mathcal{B}_n\}$ and every C -short geodesic curve β in \mathcal{K} we have:*
 - i) *If β is a loop, then β lies in some 1-boundary of \mathcal{K} . In particular, $\mathcal{A}_{n+1}, \mathcal{B}_{n+1}, \mathcal{A}_{n+2}$ and \mathcal{B}_{n+2} don't contain C -short geodesic loops.*
 - ii) *If $K \in \{\mathcal{B}_1, \dots, \mathcal{B}_n\}$ and the endpoints of β lie in 1-boundaries of \mathcal{K} , then β lies completely in one 1-boundary component of \mathcal{K} .*
 - iii) *If $K \in \{\mathcal{A}_{n+1}, \mathcal{B}_{n+1}, \mathcal{A}_{n+2}, \mathcal{B}_{n+2}\}$ and the endpoints of β lie on a boundary component of \mathcal{K} , then β lies completely in this boundary component.*

We are now able to construct the required covering space $\tilde{\mathcal{O}}$ of \mathcal{O} representing some subgroup D of $G\pi_1(\mathcal{O})$ such that $g^h \notin D$ for any $h \in G$:

Construction 6.47 (Construction of $\tilde{\mathcal{O}}$). *Let d be the minimum of distances between different boundary components of each of the surfaces $\{\mathcal{A}_{n+1}, \mathcal{B}_{n+1}, \mathcal{A}_{n+2}, \mathcal{B}_{n+2}\}$, and let T be the minimal odd number such that $T > C/d$, where C is the length of γ . The construction up to Step 3 is illustrated by figure 24.*

Step 1: Recall that, for every $i \in \{1, \dots, n\}$ the space \mathcal{A} contains a single $(R_i, 1)$ -boundary and the space B_i contains $2M$ copies of $(R_i, 1)$ -boundaries. We glue $2M$ copies of \mathcal{A} to $\mathcal{B}_1, \dots, \mathcal{B}_n$ along the corresponding 1-boundaries so that in the resulting space \mathcal{O}_1 each copy of \mathcal{A} is completely surrounded by $\mathcal{B}_1, \dots, \mathcal{B}_n$ and \mathcal{O}_1 has no $(R_i, 1)$ -boundaries. Then \mathcal{O}_1 contains only M -boundaries and $2M$ -boundaries. These boundaries lie in the B_i -subspaces. Moreover, the number of (R_i, M) -boundaries of \mathcal{O}_1 does not depend on i . The same is true for the $(R_i, 2M)$ -boundaries of S_1 .

Step 2: To each boundary component of \mathcal{O}_1 glue a copy of \mathcal{A}_{n+1} or \mathcal{A}_{n+2} along the corresponding boundary component. The resulting space \mathcal{O}_2 contains only M -boundaries and $2M$ -boundaries, and these boundaries lie in the \mathcal{A}_{n+1} -subspaces and in the \mathcal{A}_{n+2} -subspaces, respectively.

Step 3: To each boundary component of \mathcal{O}_2 we glue a copy of \mathcal{B}_{n+1} or \mathcal{B}_{n+2} along the corresponding boundary component. The resulting space \mathcal{O}_3 contains only M -boundaries and $2M$ -boundaries, and these boundaries lie in the \mathcal{B}_{n+1} -subspaces and in the \mathcal{B}_{n+2} -subspaces, respectively.

Step 4 to T : We continue the process by applying the procedure described in Steps 2 and 3 alternately to current spaces \mathcal{O}_i until we get the space \mathcal{O}_T , where T is the constant defined above. The space \mathcal{O}_T contains only M - and $2M$ -boundaries, and since T is odd, these boundaries lie in \mathcal{B}_{n+1} -subspaces or in \mathcal{B}_{n+2} -subspaces. Moreover, the number of (R_i, M) -boundaries of \mathcal{O}_T does not depend on i .

Step $T+1$: Recall that the number of (R_i, M) -boundaries of \mathcal{A}_{n+1} does not depend on i , and the number of $(R_i, 2M)$ -boundaries of \mathcal{A}_{n+2} does not depend on i . We glue several copies of \mathcal{O}_T and several copies of \mathcal{A}_{n+1} and \mathcal{A}_{n+2} so that

- a) the underlying graph is connected and has girth at least $T + 1$ (use Lemma 6.45),*
- b) the resulting space is a closed 2-orbifold.*

We denote this 2-orbifold by $\tilde{\mathcal{O}}$.

Clearly, $\tilde{\mathcal{O}}$ is a finite cover of \mathcal{O} containing a copy of \mathcal{A} . We shall show that γ has no closed lifts in $\tilde{\mathcal{O}}$.

Definition 6.48. *Let c be a curve in $\tilde{\mathcal{O}}$. A subcurve c_1 of c is called a peak of c if c_1 lies in a copy of $\mathcal{K} \in \{\mathcal{A}_{n+1}, \mathcal{B}_{n+1}, \mathcal{A}_{n+2}, \mathcal{B}_{n+2}\}$ and has endpoints on a boundary component of \mathcal{K} , and at least one point in the interior of \mathcal{K} .*

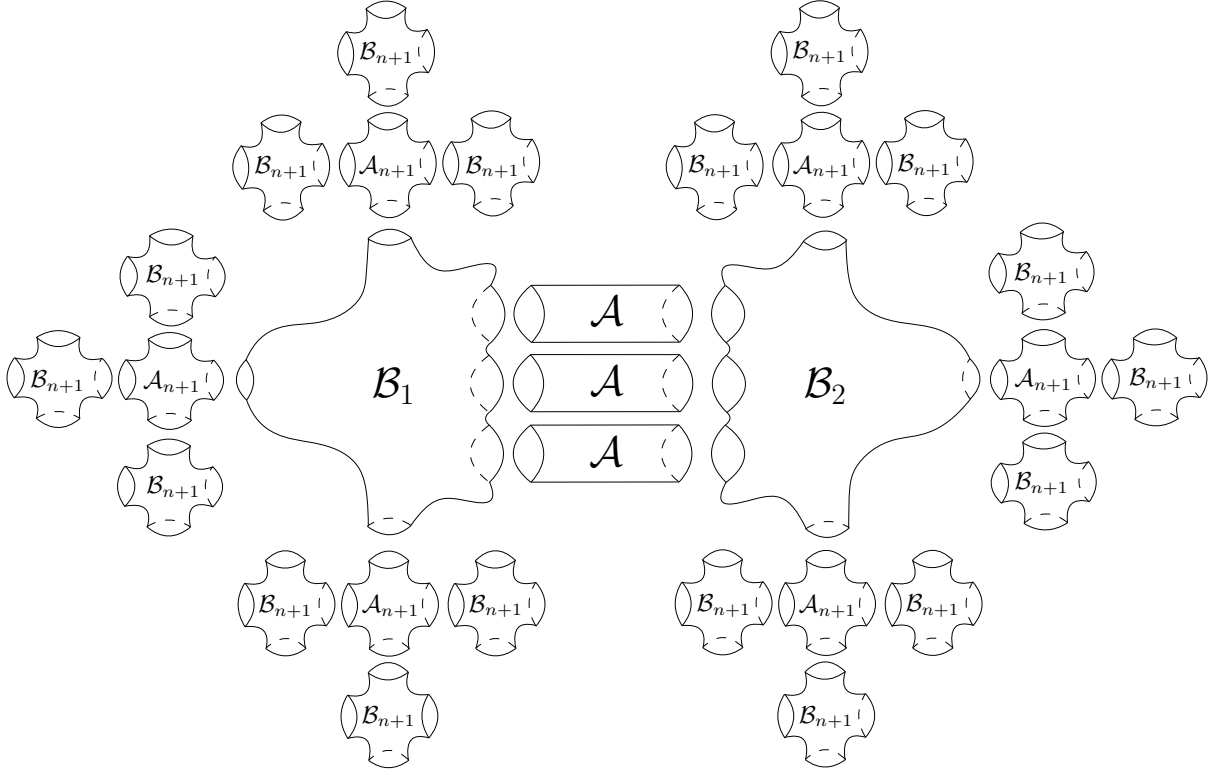

Figure 24: Gluing along the corresponding boundaries gives an example of the 2-orbifold \mathcal{O}_3 with parameters $n = 2$, $N = 2$, $M = 3$. For simplicity, we assume here that $N' = N'' = 0$.

Note that the proof of the following crucial statement is nearly same as that one of Proposition 8.1. [3]:

Proposition 6.49. *The element $g \in \pi_1(\mathcal{O})$ is not conjugate into the subgroup D represented by $\tilde{\mathcal{O}} \rightarrow \mathcal{O}$.*

Proof: Note that by construction any cone point of $\tilde{\mathcal{O}}$ lies in some copy of \mathcal{A} . Therefore the case where g acts elliptically on X is trivial. So let $\varphi : X \rightarrow \mathcal{O}$, $x \in \varphi^{-1}(o_0)$ and let γ be the path of length C connecting the two points x and gx . As already said $g^x \in D$ if and only if there exists a closed lift of γ in $\tilde{\mathcal{O}}$. Suppose that $\tilde{\gamma}$ is such a lift. Then the length of $\tilde{\gamma}$ is equal to the length of γ which is C . Moreover, $\tilde{\gamma}$ is geodesic as γ is. The curve $\tilde{\gamma}$ cannot cross different copies of \mathcal{O}_1 , otherwise it crosses at least $(2T - 1)$ copies of the spaces $\{\mathcal{A}_{n+1}, \mathcal{B}_{n+1}, \mathcal{A}_{n+2}, \mathcal{B}_{n+2}\}$, and the length of $\tilde{\gamma}$ would be at least $(2T - 1)d > C$, a contradiction. By analyzing the construction of $\tilde{\gamma}$, we conclude that either $\tilde{\gamma}$ lies completely in a copy of $\mathcal{K} \in \{\mathcal{A}_{n+1}, \mathcal{B}_{n+1}, \mathcal{A}_{n+2}, \mathcal{B}_{n+2}\}$, or $\tilde{\gamma}$ has a peak in a copy of \mathcal{K} , or $\tilde{\gamma}$ lies completely in a copy of \mathcal{O}_1 . The first is impossible by Condition 2.i), the second by Condition 2.iii). Thus, we may assume that $\tilde{\gamma}$ lies in \mathcal{O}_1 . Then $\tilde{\gamma}$ meets a copy of \mathcal{A} , otherwise it lies completely in a copy of \mathcal{B}_i for some $i \in \{1, \dots, n\}$ that contradicts Condition 2.i). Suppose that $\tilde{\gamma}$ intersects the interior of \mathcal{B}_i . Then there is a subcurve of $\tilde{\gamma}$ which intersects the interior of \mathcal{B}_i and has endpoints on 1-boundary components of \mathcal{B}_i . This contradicts Condition 2.ii). Hence $\tilde{\gamma}$ lies completely in a copy of \mathcal{A} . But this contradicts the assumption that γ cannot be freely homotoped into \mathcal{A} . This shows that γ has no closed lifts in $\tilde{\mathcal{O}}$. This proves Theorem 6.42 and therefore as previously discussed it follows that any finitely generated Fuchsian group is SCS (Theorem 6.2). \square

7 Totally Orientable Seifert-Fibered-Space

Since we have already shown that any Fuchsian group is subgroup conjugacy separable, it is natural to think about a proof for the SCS property for fundamental groups of totally orientable Seifert fibered-spaces, since by Definition 6.4, for any totally orientable Seifert fibered space M , there exists a short exact sequence of groups

$$1 \rightarrow C \rightarrow \pi_1(M) \rightarrow \pi_1(\mathcal{O}) \rightarrow 1$$

where \mathcal{O} is an orientable 2-dimensional orbifold and C is a cyclic group. Note that by Corollary 6.13 combined with Corollary 6.23 we can assume that \mathcal{O} is compact and hyperbolic. **Assume** that any finitely generated subgroup of $\pi_1(M)$ is con-separated in $\pi_1(M)$. Then it follows by Corollary 5.5 that $\pi_1(M)$ is SICS and since $\pi_1(M)$ does not admit expanding inner automorphisms by 5.11 combined with 5.13 it follows from 5.15 that $\pi_1(M)$ is SCS proving 6.5.

We conclude that it suffices to verify the following statement in order to prove 6.5:

Theorem 7.1. *Let M be a totally orientable Seifert fibered space, such that in the corresponding short exact sequence*

$$1 \rightarrow C \rightarrow \pi_1(M) \rightarrow H \rightarrow 1,$$

we have that $H = \pi_1(\mathcal{O})$ for some compact 2-dimensional hyperbolic orbifold \mathcal{O} . Then any finitely generated subgroup S_1 of $\pi_1(M)$ is con-separated in $\pi_1(M)$. In particular $\pi_1(M)$ is SICS.

While proving the con-separability of some finitely generated subgroup S_1 of $\pi_1(M)$ we distinguish two cases:

- (1) The image of S_1 in $\pi_1(\mathcal{O})$ is a finite subgroup.
- (2) The image of S_1 in $\pi_1(\mathcal{O})$ is an infinite subgroup.

if \mathcal{O} is supposed to be a compact 2-dimensional orbifold such that there exists some short exact sequence

$$1 \rightarrow C \rightarrow \pi_1(M) \rightarrow \pi_1(\mathcal{O}) \rightarrow 1$$

for some cyclic group C .

Note that by Lemma 5.6 it suffices to show the con-separability of S_1 in a suitable finite index subgroup G' of G . We will use this reduction in the case where the image of S_1 is infinite. The following Lemma states that in this situation there exists G' which satisfies the requirements for the proof later on.

First we will prove Theorem 7.1 for the case, where \mathcal{O} is closed. Afterwards we will conclude Theorem 7.1 for the case where \mathcal{O} is a compact hyperbolic orientable 2-dimensional orbifold with boundary components. So from now on let \mathcal{O} be a **closed** orientable 2-dimensional hyperbolic orbifold and M be a totally orientable Seifert fibered space.

Lemma 7.2. *Consider the short exact sequence*

$$1 \rightarrow C \xrightarrow{\psi} G \xrightarrow{\varphi} \pi_1(\mathcal{O}) \rightarrow 1,$$

where $\psi(C) \leq Z(G)$ and let $S_1 \leq G$ such that $\varphi(S_1)$ is an **infinite** subgroup of $\pi_1(\mathcal{O})$. Then there exist a finite-sheeted orbifold cover $\mathcal{O}' \rightarrow \mathcal{O}$ and a short exact sequence of groups

$$1 \rightarrow C' \xrightarrow{\psi'} G' \xrightarrow{\varphi'} \pi_1(\mathcal{O}') \rightarrow 1$$

such that $|G : G'| < \infty$, $\psi(C') \leq Z(G')$ and $S_1 \leq G'$ and $\varphi'(S_1)$ is a geometric subgroup of a good shape in $\pi_1(\mathcal{O}')$.

Proof: By Theorem 6.18 in combination with Lemma 6.24, we know that $H_1 := \varphi(S_1)$ is almost geometric in $H := \pi_1(\mathcal{O})$. Hence by applying Corollary 6.38 there exists a finite index subgroup H' of H containing H_1 , which is represented by a finite-sheeted cover $\mathcal{O}' \rightarrow \mathcal{O}$ such that H_1 is realizable by a sub-2-orbifold \mathcal{A} of a good shape. Setting $G' := \varphi^{-1}(H')$ and $C' := \psi^{-1}(\psi(C) \cap G')$ the induced short exact sequence

$$1 \rightarrow C' \xrightarrow{\psi|_{C'}} G' \xrightarrow{\varphi|_{G'}} H' \rightarrow 1$$

has the required properties, since obviously G' is a subgroup of finite index in G containing S_1 . \square

So by Lemma 5.6, we know that a f.g. generated subgroup S_1 is con-separated in G if it is con-separated in the corresponding finite index subgroup G' of G . So w.l.o.g. we can assume that in the case, where the image $\varphi(S_1)$ of $S_1 \leq G$ in $\pi_1(\mathcal{O})$ is infinite, $\varphi(S_1)$ is a subgroup of a good shape, i.e. is realizable by sub-2-orbifold of a good shape.

As before we only have to show the con-separability for elements which are not conjugate into our subgroup S_1 since the following two statements imply that S_1 is con-separated in G provided S_1 is con-separated from any element not conjugate into S_1 in G .

Lemma 7.3. *Consider the short exact sequence of groups*

$$1 \rightarrow C \xrightarrow{\psi} G \xrightarrow{\varphi} H \rightarrow 1$$

with $C \leq Z(G)$ and let $S_1, S_2 \leq G$ such that

- (1) For any $s \in S_2$ there exists $g \in G$ with $s^g \in S_1$.
- (2) There exists a subgroup U of G such that $S_1 \trianglelefteq U$ and $\varphi(U)$ is malnormal in H .
- (3) $\varphi(S_2) \leq \varphi(S_1)$ and therefore $S_2 \leq S_2 \cdot C \leq S_1 \cdot C$.

Then $S_2 \leq S_1$.

Proof: W.l.o.g. we identify C with $\psi(C)$. Let $S_1, S_2 \leq G$ satisfying (1),(2) and (3). Then for any $s \in S_2$ there exists $g \in G$ such that $s^{g^{-1}} \in S_1$. If $s \in C$, we have $s = s^{g^{-1}} \in S_1$. So let $s \notin C$. By assumption there exists a subgroup U of G such that $S_1 \trianglelefteq U$ and $\varphi(U)$ is malnormal in H and since $s \in S_1^g$ and $s \in S_2 \leq S_1 \cdot C$ we deduce $s \in S_1^g C \cap S_1 C = (S_1 C)^g \cap S_1 C$. In particular

$$\varphi(s) \in \varphi(S_1)^{\varphi(g)} \cap \varphi(S_1) \subseteq \varphi(U)^{\varphi(g)} \cap \varphi(U).$$

Since $s \notin C = \ker\varphi$ we obtain $\varphi(g) \in \varphi(U)$ by the malnormality of $\varphi(U)$ in H . It follows that $g^{-1} = u \cdot c$ for some $u \in U$ and $c \in C$ and since $C \leq Z(G)$ we have that $s^{g^{-1}} = s^{uc} = s^u \in S_1$. We conclude $s \in S_1^{u^{-1}} = S_1$ as $S_1 \trianglelefteq U$ which implies $S_2 \leq S_1$. \square

So we deduce the following:

Corollary 7.4. *Consider the short exact sequence of groups*

$$1 \rightarrow C \xrightarrow{\psi} \pi_1(M) \xrightarrow{\varphi} \pi_1(\mathcal{O}) \rightarrow 1$$

with $\psi(C) \leq Z(\pi_1(M))$ and let $S_1 \leq \pi_1(M)$ such that one of the following holds

(1) $\varphi(S_1)$ is a geometric subgroup in $H := \pi_1(\mathcal{O})$ of a good shape.

(2) $\varphi(S_1)$ is a finite subgroup of H .

Then S_1 is con-separated in G if S_1 is con-separated from every g not conjugate into S_1 .

Proof: Let $S_2 \leq G := \pi_1(M)$. As in the proof of Theorem 6.41 it suffices to show that if any element of S_2 is conjugate into S_1 , it follows that S_2 is conjugate into S_1 . So assume that for any $s \in S_2$ there exists $g \in G$ such that $s^g \in S_1$. In particular for any $s \in S_2$ there exists $g \in G$ with $\varphi(s)^{\varphi(g)} \in \varphi(S_1)$. Therefore by Lemma 6.41 there exists $g \in G$ such that $\varphi(S_2^g) = \varphi(S_2)^{\varphi(g)} \leq \varphi(S_1)$.

Case (1): If $\varphi(S_1)$ is an infinite geometric subgroup of $\pi_1(\mathcal{O})$, $\varphi(S_1)$ is either infinite cyclic and hence it can be considered as the edge group of the single edge in a 2-acylindrical HNN-extension or it corresponds to a vertex group of a 2-acylindric graph of groups (see proof of Theorem 6.41), which underlying graph consists of exactly two vertices and a finite set of edges connecting these two vertices. In both cases, it follows, that $\varphi(S_1)$ is malnormal in H .

Case (2): If $\varphi(S_1)$ is a finite subgroup of $\pi_1(\mathcal{O})$, there exists a maximal elliptic subgroup $H \cong \mathbb{Z}_n$ for some $n \in \mathbb{N}$ containing $\varphi(S_1)$, since \mathcal{O} is assumed to be orientable. Since H is abelian, we observe that $\varphi(S_1) \trianglelefteq H$ and hence $S_1 \trianglelefteq \varphi^{-1}(H) =: U$. Moreover since $\pi_1(\mathcal{O})$ cannot contain any reflection elements, it follows that any maximal finite group of $\pi_1(\mathcal{O})$ is malnormal in $\pi_1(\mathcal{O})$. In particular U is a subgroup of $\pi_1(M)$ containing S_1 as a normal subgroup such that $\varphi(U) = H$ is malnormal in $\pi_1(\mathcal{O})$.

We conclude that in both cases we are able to apply Lemma 7.3 to conclude that $S_2^g \leq S_1$. \square

For the case where the image of S_1 is finite in $\pi_1(\mathcal{O})$ we will use the following statement which was proven in [25].

Theorem 7.5. *Consider a short exact sequence of groups,*

$$1 \rightarrow E \xrightarrow{\psi} G \xrightarrow{\varphi} S \rightarrow 1,$$

where E is a finite group and S is a surface group. Then G has a subgroup of finite index which is a surface group. \square

Corollary 7.6. *Consider a short exact sequence of groups,*

$$1 \rightarrow E \xrightarrow{\psi} G \xrightarrow{\varphi} H \rightarrow 1,$$

where E is a finite group and H is virtually a surface group. Then G has a subgroup of finite index which is a surface group. In particular G is fully conjugacy separable.

Proof: So let S be a surface group of finite index in H . Note that $G' := \phi^{-1}(S)$ is of finite index in G and that there exists a short exact sequence

$$1 \rightarrow E' \xrightarrow{\psi|_{E'}} G' \xrightarrow{\varphi|_{G'}} S \rightarrow 1,$$

if we set $E' = \psi^{-1}(\psi(E) \cap G')$. By applying 7.5 it follows that G' is virtually a surface group. Thus G is virtually a surface group and we deduce by 6.15 in combination with 5.17 that G is fully conjugacy separable. \square

The following Lemma deals with the case, where the image of S_1 is finite in $\pi_1(\mathcal{O})$:

Lemma 7.7. *Consider the short exact sequence*

$$1 \rightarrow C \xrightarrow{\psi} \pi_1(M) \xrightarrow{\varphi} \pi_1(\mathcal{O}) \rightarrow 1,$$

where $\psi(C) \leq \mathbb{Z}(\pi_1(M))$ and let $S_1 \leq G := \pi_1(M)$ such that $\varphi(S_1)$ is a **finite** subgroup of $H := \pi_1(\mathcal{O})$. Then S_1 is con-separated from any element $g \in G$ not conjugate into S_1 .

Proof: So let $S_1 \leq G = \pi_1(M)$ such that $\varphi(S_1)$ is a finite subgroup of $H = \pi_1(\mathcal{O})$ and let $g \in G$ such that $g^x \notin S_1$ for any $x \in G$. Clearly we can assume that $S_1 \not\leq C$. Otherwise the claim is trivial. W.l.o.g. let $\psi = id$. Furthermore we can assume that $\mathbb{Z} \cong C$ since G is torsion free whenever G is an infinite group. It follows $S_1 \cdot C \cong \mathbb{Z}$. Thus $\mathbb{Z} \cong C' := S_1 \cap C \trianglelefteq G$. We distinguish two cases:

1. If $C' = C$ it follows $\varphi(g^x) = \varphi(g)^{\varphi(x)} \in \varphi(S_1)$ for some $x \in G$ implicates $g^x \in S_1 \cdot C = S_1$. In particular $g^x \notin S_1$ for any $x \in G$ implies that $\varphi(g)^{\varphi(x)} \notin \varphi(S_1)$ for any $x \in G$. Therefore S_1 is con-separated from any element $g \in G$ not conjugate into S_1 if $\varphi(S_1)$ is con-separated from any element $\varphi(g) \in H$ not conjugate into $\varphi(S_1)$. Hence the claim follows from Lemma 5.19 and we are done.
2. Assume that $C' \lneq C$ and let $G' := G/C'$. Moreover let $\theta : G \rightarrow G'$ be the induced epimorphism. Clearly $E := C/C'$ is a non trivial finite cyclic group and there exists a short exact sequence

$$1 \rightarrow E \xrightarrow{id} G' \xrightarrow{\varphi'} H \rightarrow 1,$$

if we set $\varphi'(gC') := \varphi(g)$ for any $g \in G$. Thus we deduce by 7.6 that G' is fully conjugacy separable implying that any finite subgroup B of G' is con-separated from each element g not conjugate into B by 5.19. Now $\theta(g^x) = \theta(g)^{\theta(x)} \in \theta(S_1)$ implies $g^x \in S_1 \cdot C' = S_1$ for any $g, x \in G$. Similarly as before we deduce that $g^x \notin S_1$ for any $x \in G$ implies that $\theta(g)^{\theta(x)} \notin \theta(S_1)$. Thus S_1 is con-separated from any element $g \in G$ not conjugate into S_1 if $\theta(S_1)$ is con-separated from any element $\theta(g) \in G'$ not conjugate into the finite subgroup $\theta(S_1)$ of G' concluding the proof. \square

So we are left with the case where the image of S_1 is an infinite subgroup of $\pi_1(\mathcal{O})$. Like mentioned before, we can assume that this image is a geometric subgroup of a good shape in $\pi_1(\mathcal{O})$. For the proof we will use the following statement. A proof can be found in [37]:

Lemma 7.8. Consider the short exact sequence

$$1 \rightarrow C \xrightarrow{\psi} \pi_1(M) \xrightarrow{\varphi} \pi_1(\mathcal{S}) \rightarrow 1,$$

where $\psi(C) \leq Z(G)$ and \mathcal{S} is a surface such that $\pi_1(\mathcal{S})$ is free of rank $n \geq 2$. Then the above sequence splits. In particular $G \cong C \times \pi_1(\mathcal{S})$. \square

So we are now able to prove the following important statement:

Theorem 7.9. Consider the short exact sequence

$$1 \rightarrow C \xrightarrow{\psi} \pi_1(M) \xrightarrow{\varphi} \pi_1(\mathcal{O}) \rightarrow 1,$$

where $\psi(C) \leq Z(G)$ and let $S_1 \leq G$ such that $\varphi(S_1)$ is an **infinite** geometric subgroup in $\pi_1(\mathcal{O})$ of a good shape. Then S_1 is con-separated from each element $g \in G$ not conjugate into S_1 .

Proof: So let $S_1 \leq G := \pi_1(M)$ such that $H_1 := \varphi(S_1)$ is an infinite geometric subgroup in $H := \pi_1(\mathcal{O})$ of a good shape and let $g \in G$ such that $g^x \notin S_1$ for any $x \in G$. If $\varphi(g)^{\varphi(x)} \notin H_1$ for any $x \in G$ the statement would follow from Theorem 6.42. Hence we can assume that there exists $x \in G$ such that $\varphi(g^x) = \varphi(g)^{\varphi(x)} \in H_1$ and therefore $g^x \in S_1 \cdot C$ for some $x \in G$. Since H_1 is an **infinite** geometric subgroup in $\pi_1(\mathcal{O})$ of a good shape there exists $H_2 \leq \pi_1(\mathcal{O})$ such that $\pi_1(\mathcal{O})$ can be realized as the fundamental group of the following graph of groups:

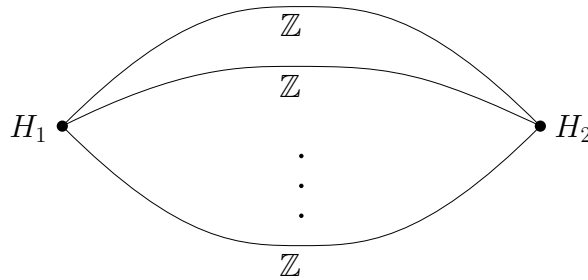

Figure 25: Graph of groups splitting of $\pi_1(\mathcal{O})$.

Since φ is a surjective group homomorphism we obtain the following graph of groups decomposition for $\pi_1(M)$:

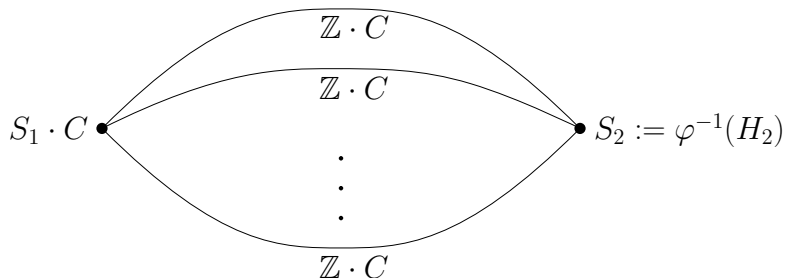

Figure 26: Graph of groups splitting of $\pi_1(M)$.

Moreover H_2 is the fundamental group of a sub-2-orbifold \mathcal{B} of \mathcal{O} with boundary. Furthermore $g(\mathcal{B}) \geq 1$, since $\varphi(S_1) = H_1$ is realized by a sub-2-orbifold of a good shape.

Therefore we can apply Corollary 6.31 to \mathcal{B} and conclude, that there exists a finite-sheeted covering \mathcal{S} of \mathcal{B} such that for any boundary R of \mathcal{B} we have exactly $n(R, 1)$ boundaries and these are the only covers of R . Clearly this finite-sheeted covering represents a finite index subgroup H'_2 of H_2 such that H'_2 is a finitely generated free group of rank $n \geq 2$, since \mathcal{S} is a surface with boundary with $g(\mathcal{S}) \geq 1$. Hence we deduce that there exists a finite index subgroup D_H of H which is represented by the following graph of groups:

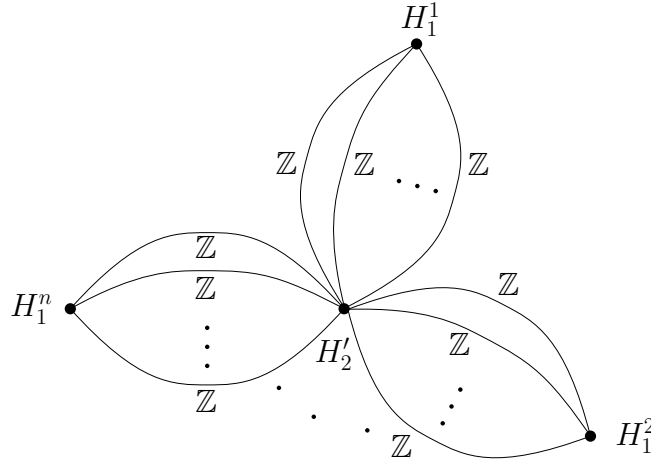

Figure 27: Graph of groups splitting of the finite index subgroup D_H of H .

where the H_1^i , $i \in \{1, \dots, n\}$, are copies of H_1 . By setting $H_1^1 := H_1$ we can assume that $\varphi(S_1)$ lies in D_H . Note that since H'_2 is a free group of rank ≥ 2 , we can in addition assume that $S'_2 := \varphi^{-1}(H'_2) \cong H'_2 \times C$ as the induced short exact sequence

$$1 \rightarrow C \rightarrow S'_2 \rightarrow H'_2 \rightarrow 1$$

splits by 7.8. So we conclude that the upcoming graph of groups represents the preimage $D_G := \varphi^{-1}(D_H)$ in G :

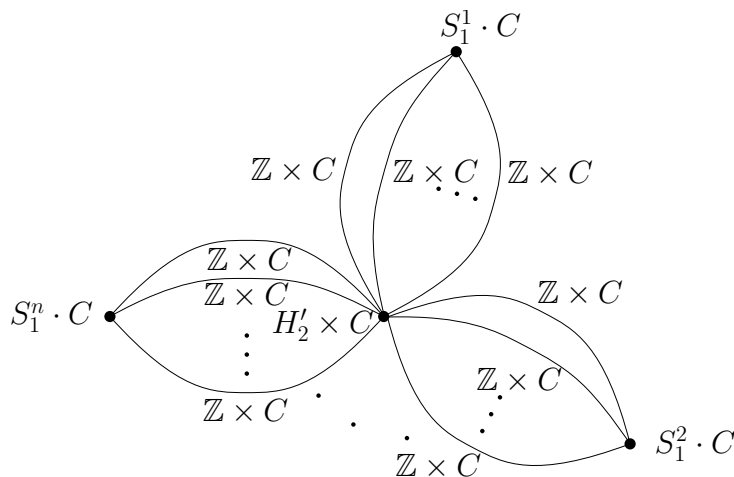

Figure 28: Graph of groups splitting of the finite index subgroup D_G of G .

Note that D_G is a finite index subgroup of G containing H_1 and that $g^x \in S_1 \cdot C \leq D_G$ for some $x \in G$. So w.l.o.g. assume taht $g \in S_1 C \leq D$. We distinguish the following cases:

Case 1: Let $g \in C$. Then we have that $g^x \notin S_1$ for any $x \in G$ if and only if $g \notin S_1$ since $C \leq Z(G)$. Thus there exists a finite index subgroup C' of C such that $g \notin C'$ and $S_1 \cap C \leq C'$. Clearly there exists a graphs of groups morphism, such that the graph of groups

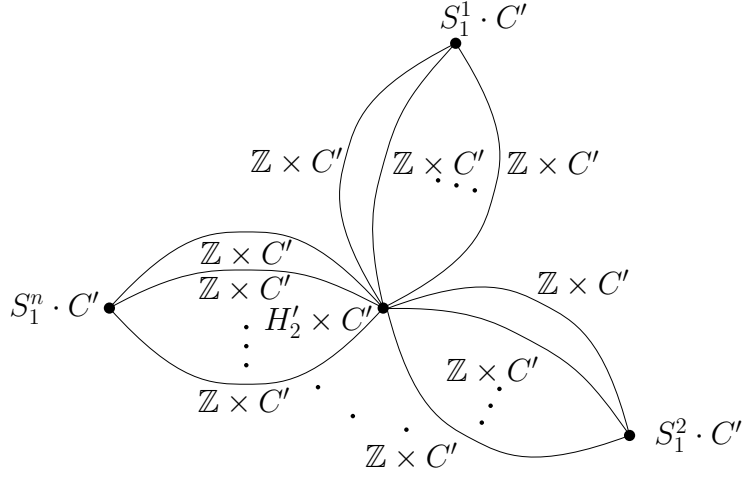

Figure 29: Graph of groups representing D .

represents a finite index subgroup D in D_G containing S_1 . Hence D is a finite index subgroup of G , with the property that $g \notin D$. Again we have $g \notin D$ if and only if $g^x \notin D$ as $g \in C \leq Z(G)$ and since $S_1 \leq D$ we conclude that D is the desired subgroup of finite index of G .

Case 2a: Assume that $g \notin C$ and let $S_1 \cap C = 1$. Then $g \in S_1 \cdot C = S_1 \times C$ since $C \leq Z(G)$. Thus there exists unique $s \in S_1$ and $c \in C$ satisfying $g = s \cdot c$. Clearly there exists a subgroup $C' \leq C$ such that $c \notin C'$. Since $g \in S$ Let $x \in G$ such that $g^x \in S_1 \cdot C$. Constructing D as in the first case for C' , we obtain a subgroup D of finite index containing S_1 such that $c \notin D$ implying that $g \notin D$. Assume that $g^x = s^x \cdot c^x = s_1^x \cdot c \in D$ for some $x \in G$ implying that $g \in S_1 C \cap (S_1 C)^{x^{-1}}$. If $x^{-1} \notin S_1 C$ we have $g \in C$ as $\varphi(g) \in \varphi(S_1) \cap \varphi(S_1)^{\varphi(x^{-1})} = 1$ by the malnormality of $\varphi(S_1)$ in H . A contradiction. Thus there exists $s' \in S_1$ and $c' \in C$ such that $x = s' \cdot c'$ and therefore $g^x = s^{s'c'} c^{s'c'} = s^{s'} c \in D$. Hence $c \in D$ since $s^{s'} \in S_1 \leq D$. A contradiction.

Case 2b: Assume that $g \notin C$ and let $S_1 \cap C = C'$. Observe that C' is of finite index in $C \cong \mathbb{Z}$. Define D again as in the first case. Hence D is a subgroup of finite index in G containing S_1 and there exists a graph of group morphism, such that D is represented by:

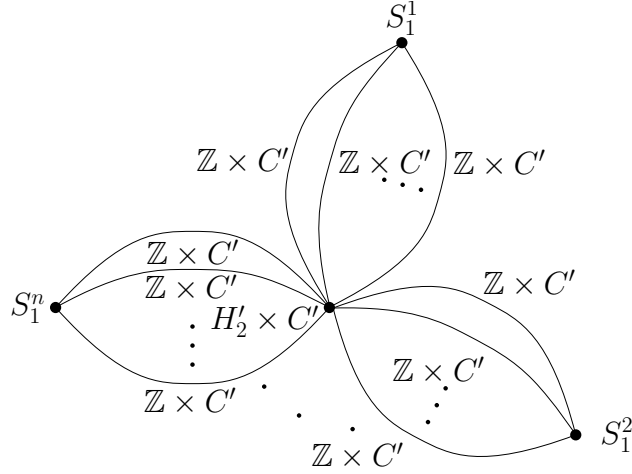

Figure 30: Graph of groups representing D .

where S_1^i is a copy of S_1 for any $i \in \{1, \dots, n\}$. So assume that $g^x \in D$ implying that $g^x \in (S_1 \cdot C)^x \cap D = S_1^x \cdot C \cap D = S_1^x \cdot C' = S_1^x$ since $g \in S_1 \cdot C$. Clearly this provides the conclusive contradiction, since g was assumed to be not conjugate into S_1 . \square

We conclude that Theorem 6.5 is true for any fundamental group of a Seifert fibered space, where in the corresponding short exact sequence the 2-dimensional orbifold is closed. So we are left to show the following:

Corollary 7.10. *Let $\widehat{\mathcal{O}}$ be a compact orientable 2-dimensional orbifold with boundary. Consider the short exact sequence*

$$1 \rightarrow C \xrightarrow{\widehat{\psi}} \widehat{G} \xrightarrow{\widehat{\varphi}} \pi_1(\widehat{\mathcal{O}}) \rightarrow 1,$$

where $\widehat{G} = \pi_1(\widehat{M})$ for some Seifert fibered space \widehat{M} , $\psi(C) \leq \mathbf{Z}(\widehat{G})$ and let $S_1 \leq \widehat{G}$ such that $\varphi(S_1)$ is a subgroup in $\pi_1(\widehat{\mathcal{O}})$. Then S_1 is con-separated from each element $g \in \widehat{G}$ not conjugate into S_1 .

Proof: Clearly there exists a short exact sequence

$$1 \rightarrow C \xrightarrow{\psi} G \xrightarrow{\varphi} \pi_1(\mathcal{O}) \rightarrow 1,$$

such that the following holds:

- (1) There exists a surface S with boundary and $g(S) > 0$ such that G admits the following graph of groups decomposition:

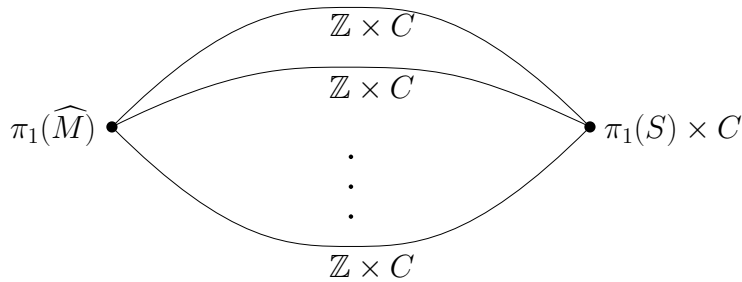

Figure 31: Graph of groups splitting of G .

(2) $\varphi|_{\widehat{G}} = \widehat{\varphi}$.

(3) \mathcal{O} is a **closed** 2-dimensional orbifold with graph of groups decomposition

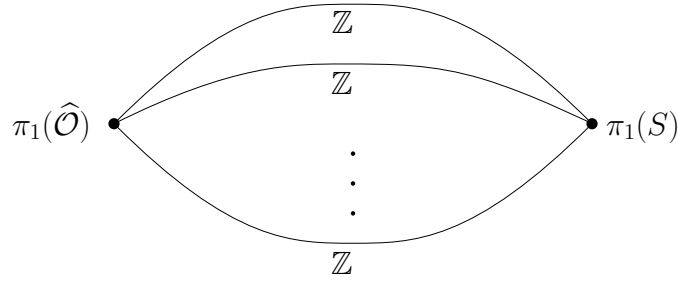

Figure 32: Graph of groups splitting of $\pi_1(\mathcal{O})$.

(4) $\widehat{H} := \varphi(\widehat{G}) = \pi_1(\widehat{\mathcal{O}})$ is malnormal in $H := \pi_1(\mathcal{O})$.

So let $S_1 \leq \widehat{G}$ such that $H_1 := \varphi(S_1) = \widehat{\varphi}(S_1)$ and let $g \in \widehat{G}$ such that $g^x \notin S_1$ for any $x \in \widehat{G}$. Assume that there exists an element $x \in G \setminus \widehat{G}$ such that $g^x \in S_1$. Then $\varphi(g)^{\varphi(x)} \in \widehat{H} \cap \widehat{H}^{\varphi(x)}$ and therefore $g \in C$ or $x \in \widehat{G} \cdot C = \widehat{G}$ as \widehat{H} is malnormal in H . A contradiction since $g \notin S_1$ and $C \leq Z(G)$. Hence $g^x \notin S_1$ for any $x \in G$. It follows that by Theorem 7.9 there exists a finite index subgroup D of G , containing S_1 with the property that $g^x \notin D$ for any $x \in G$. We conclude that $\widehat{D} := \widehat{G} \cap D$ is the desired finite index subgroup of \widehat{G} containing S_1 with the property that $g^x \notin \widehat{D}$ for any $x \in \widehat{G}$. \square

Therefore we have proven Theorem 7.1 which implicates the aim of this chapter: Theorem 6.5.

References

- [1] H. Bass, Covering theory for graphs of groups, *J. Pure Appl. Algebra* 89 (1993), no. 1-2, 3–47. MR 94j:20028
- [2] O. Bogopolski and F. Grunewald, On subgroup conjugacy separability in the class of virtually free groups, *Max-Planck-Institute of Mathematics Preprint Series*, n. 110 (2010), 18 pages. arXiv:1012.5122.
- [3] O. Bogopolski and K.-U. Bux, Subgroup conjugacy separability for surface groups, arXiv:1401.6203.
- [4] O. Bogopolski and K.-U. Bux, On Subgroup conjugacy separability for hyperbolic $QV\mathcal{H}$ -groups, arXiv:1602.03229v2.
- [5] F. Bonahon, Geometric structures on 3-manifolds, in: R.J. Daverman, R.B. Sher (Eds.), *Handbook of Geometric Topology*, Elsevier Science, Amsterdam, 2002, pp. 93-164.
- [6] A.M. Brunner, R.G. Burns, and D. Solitar, The subgroup separability of free products of two free groups with cyclic amalgamation, *Contemp. Math.* 33, A.M.S., Providence, R. I., 1984, 90115.
- [7] R.G. Burns, On infinitely generated subgroups of free products, *J. Austr. Math. Soc.* 12 (1971), 358-364.
- [8] S.C. Chagas and P.A. Zalesskii, Limit groups are subgroup conjugacy separable, *Journal of Algebra*, Volume 461. 1. September 2016, 121-128.
- [9] S.C. Chagas and P.A. Zalesskii, Subgroup conjugacy separability of free-by-finite groups, *P.A. Arch. Math.* (2015) 104: 101. doi:10.1007/s00013-015-0727-8
- [10] J.L.Dyer, Separating conjugates in free-by-finite groups, *J. London Math. Soc.* 20 (2) (1979), 215-221.
- [11] A.L. Edmonds, R.S. Kulkarni and R.E. Stong, Realizability of branched coverings of surfaces, *TAMS*, 282, (2) (1984), 773-790.
- [12] Ahmed Noubi Sayed Elsayy, Subgroup Into-Conjugacy Separability Property for Groups ,PhD-Thesis, online available at: <https://docserv.uni-duesseldorf.de/servlets/DocumentServlet?id=21715>
- [13] B. Farb, D. Margalit, *A primer on mapping class groups*, Chapter 10.
- [14] R. Gitik, Graphs and separability properties of groups, *J. Algebra*, 188 (1) (1997), 125-143.
- [15] R. Gitik and E. Rips, A necessary condition for $A *_a=b B$ to be LERF, *Israel J. Math.* 73 (1) (1991), 123-125.
- [16] A.V. Gorjaga, Example of a finite extension of an FAC-group that is not an FAC-group, (Russian), *Sibirsk. Mat. Zh.*, 27 (3) (1986), 203-205.

- [17] M. Hall, Coset representatives in free groups, *Trans. Am. Math. Soc.* 67 (1949), 421-432.
- [18] Hurwitz, Uber Rieman'sche Flächen mit gegebenen Verzweigungspunkten, *Math. Ann.*, 103 (1881), 1-60.
- [19] D. Husemoller, Ramified coverings of Riemann surfaces, *Duke Math. J.*, 29 (1962), 167-184.
- [20] Gregory Karpilovsky, *Topics in Field Theory*, North-Holland Mathematics Studies, Volume 155, 1989, Chapter 6, Pages 299-373
- [21] A. Karrass, A. Pietrowski and D. Solitar, Finite and infinite cyclic extensions of free groups, *J. Australian Math. Soc.*, 16 (1973), 458-466.
- [22] O. Kharlampovich, A. Miasnikov, Irreducible affine varieties over a free group. II Systems in triangular quasi-quadratic form and description of residually free groups, *J. Algebra* 200:2 (1998), 517-570.
- [23] Svetlana Katok, *Fuchsian Groups*, ISBN(cloth): 0226-42582-7, ISBN (paper): 0-226-42583-5, The University of Chicago Press. Chicago 60637
- [24] A.I. Mal'cev, On homomorphisms onto finite groups, *Uchen. Zap. Ivanovskogo Gos. Ped. Inst.*, 18 (5) (1958), 49-60. English transl: On homomorphisms onto finite groups, *Amer. Math. Soc. Translations*, Series 2, 119 (1983), 67-79.
- [25] A. Martino, A proof that all Seifert 3-manifold groups and all virtual surface groups are conjugacy separable, *J. Algebra* 313 (2007), no. 2, 773-781.
- [26] A. Martino, A. Minasyan, Conjugacy in normal subgroups of hyperbolic groups, Preprint. Available at <http://arxiv.org/abs/0906.1606>
- [27] V. Metaftsis, E. Raptis, On the profinite topology of right-angled Artin groups, *J. of Algebra*, 320 (3), 2008, 1174-1181.
- [28] F. Pakovich, Solution of the Hurwitz problem for Laurent polynomials, 2007, preprint in arxiv.
- [29] E. Pervova, C. Petronio, On the existence of branched coverings between surfaces with prescribed branch data, I, *Algebraic and Geometric Topology*, 6 (2006), 1957-1985.
- [30] E. Pervova, C. Petronio, On the existence of branched coverings between surfaces with prescribed branch data, II, 2008, preprint in arxiv.
- [31] C. Reinfeldt and R. Weidmann, Makanin-Razborov diagrams for hyperbolic groups. preprint, 2010.
- [32] L. Ribes and P.A. Zalesskii, *Profinite Groups*, ISBN 978-3-642-01641-7, e-ISBN 978-3-642-01642-4, Springer Verlag Berlin Heidelberg 2000, 2010
- [33] L. Ribes and P.A. Zalesskii, Conjugacy distinguished groups, *Journal of Group Theory*, ISSN (Online) 1435-4446, ISSN (Print) 1433-5883, DOI: <https://doi.org/10.1515/jgth-2016-0502>

- [34] I. Rips, An example of a non-LERF group which is a free product of LERF groups with an amalgamated cyclic subgroup, *Israel Journal of Mathematics*, 70 (1) (1990), 104-110.
- [35] N.S. Romanovskii, On the residual finiteness of free products with respect to subgroups (Russian), *Izv. Akad. Nauk SSSR, Ser. Mat.*, 33 (1969), 1324-1329.
- [36] P. Scott, Subgroups of surface groups are almost geometric, *J. London Math. Soc.*, 17 (3) (1978), 555-565. See also *ibid* Correction: *J. London Math. Soc.*, 32 (2) (1985), 217-220.
- [37] Peter Scott, The geometries of 3-manifolds, *Bull. London Math. Soc.* 15 (1983), no. 5, 401-487. MR MR705527 (84m:57009)
- [38] D. Segal, *Polycyclic groups*, Cambridge University Press, 1983.
- [39] Jean-Pierre Serre, *Trees*, ISSN 1439-7382, ISBN 3-540-44237-5 Springer-Verlag Berlin Heidelberg New York
- [40] P.F. Stebe, A residual property of certain groups, *Proc. AMS*, 26 (1970), 37-42.
- [41] M. Takahasi, Note on chain conditions in free groups, *Osaka Math. J.*, 3, (1951), 221-225.
- [42] M. Tretkoff, Covering spaces, subgroup separability, and the generalized M. Hall property, in: *Combinatorial group theory (Proc. AMS. Spec. Sess., College Park, MD, USA 1988)*, *Contemporary Math.*, 109 (1990), 179-191.
- [43] W.C. Waterhaus, Profinite groups are Galois groups, *Proc. Amer. Math. Soc.*, (1974), pp. 639-640.
- [44] R. Weidmann, *Geometric group theory II (Lecture Notes)*
- [45] H. Wilton, Halls Theorem for Limit Groups, *Geom. Funct. Anal.*, 18 (2008): 271-303.
- [46] D. Wise, Subgroup separability of graphs of free groups with cyclic edge groups, *Q. J. Math.* 51 (1) (2000), 107-129.